



EMISSIONS TECHNOLOGIES®



2022

Catalytic Converters : Mufflers : Exhaust Pipes : Accessories

Catalyseurs : Silencieux : Pots d'échappement : Accessoires

Convertidores catalíticos : Silenciadores : Tubos de escape : Accesorios

MSL®
Muffler Shop Line

**Professional
Installer
Catalog**



Catalogo de Instalacion Profesional
Catalogue pour les instalateurs professionnels

BUILT RIGHT
DONE RIGHT
FIRST TO MARKET



WE ARE THE INDUSTRY LEADERS IN
EMISSIONS & EXHAUST AFTERMARKET

AP Emissions Technologies
Catalog & Content Center
McHenry, IL 60051
815-679-6399

AP Emissions App



AP Emissions Catalog features comprehensive application data for exhaust and catalytic converter replacement parts. **Mufflers, Exhaust Pipes, Exhaust Accessories, Direct Fit and Universal Converters.**

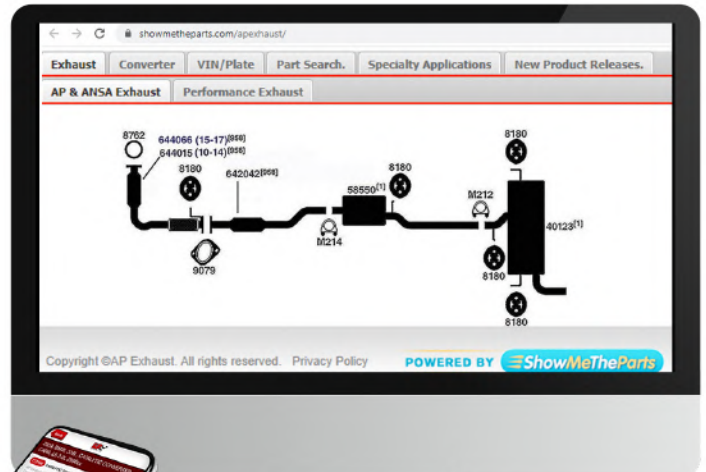

showmethparts.com/apexhaust



Proud to Be an
American Manufacturer



AP Emissions Technologies is a
Clean and Energy Focused Manufacturer

TABLE OF CONTENTS



Universal EPA Converters.....	2-11
Select + Plus Universal EPA Converters.....	12-13
MSL Maximum Direct Fit Mufflers - Applications By Make.....	14-63
MSL Maximum Muffler Specifications - By Part Number.....	64-92
MSL Maximum Muffler Specifications - By Universal Dimension.....	93-111
MSL Maximum Muffler Numerical Listing.....	112-122
Xlerator High Performance Mufflers - Stainless Steel, VX, VR.....	123-129
Xlerator All-Welded Performance Mufflers.....	130-131
Big Max Aluminized Turbo Mufflers.....	132-133
Enforcer Aluminized Glasspacks.....	134-135
Enforcer Aluminized Turbopacks & Torpedopacks.....	136
Header Gaskets & Flanges.....	137
Cherry Bomb Performance Mufflers.....	138-154
Glasspacks.....	138-140
M-80.....	141
Salute.....	142-145
Vortex.....	146-147
Extreme.....	148
Pro.....	149-151
Turbo.....	152-153
Hot Rod.....	154
Cherry Bomb Accessories.....	155-157
Enforcer II Economy Mufflers.....	158-161
Universal All Welded Aluminized Heavy Duty Truck Mufflers.....	162
Flex & Repair Exhaust Pipe.....	163-165
Max Fit Exhaust & Tailpipes.....	166-179
Numerical Listing of Max Fit Pipes w/Overall Length.....	180-184
Accessories.....	
Clamps.....	185-190
Hangers.....	191-194
Brackets, Straps & Grommets.....	195
Heat Shields, Heat Risers, Split Flanges & Stud Repair Kits.....	196-197
Bolts, Nuts, Screws.....	197-198
Studs, Washers & Shims.....	198-199
Manifold Shoulder Bolts & Springs, Joint Connector.....	199-200
Catalytic Converter Accessories.....	201
Universal & Special Application Flanges.....	202
Exhaust Pipe Flange Charts.....	203-205
Exhaust Gasket Charts w/Specs.....	206-212
Elbows, Reducers, Connectors, Adapters.....	213-220
Flex Coupling.....	221
Y-Pipes, Splitter T's, HD Flanges, Tubes, Inserts.....	222-223
Flex Tubing, Bellows.....	223-224
Straight Tubing.....	225
Chrome Tips.....	226-227
Stainless Tips.....	228-232
Tail Spouts.....	232
Silverline Tips.....	233-236
Tools.....	237

CATALYTIC CONVERTERS

6020**/6022** Series

STANDARD DUTY

STANDARD DUTY	EPA Eng./Test Weight
2-WAY	5.9L, 5500 lbs
3-WAY	5.9L, 5500 lbs
3-WAY, w/Air	5.9L, 5500 lbs

Oval - w/Air Tube

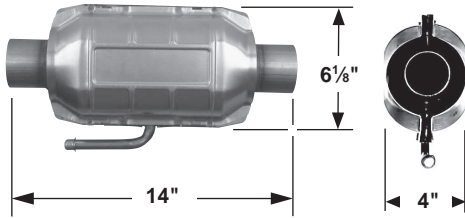

INLET/I.D.

OUTLET/I.D.

602003	1-3/4"	1-3/4" w/air tube
602004	2"	2" w/air tube
602005	2-1/4"	2-1/4" w/air tube
602006	2-1/2"	2-1/2" w/air tube
602007	3"	3" w/air tube

Oval - w/o Air Tube

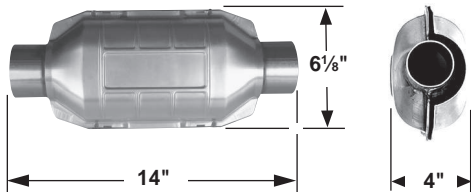

INLET/I.D.

OUTLET/I.D.

602203	1-3/4"	1-3/4" w/o air tube
602204	2"	2" w/o air tube
602205	2-1/4"	2-1/4" w/o air tube
602206	2-1/2"	2-1/2" w/o air tube
602207	3"	3" w/o air tube

602*** SPECIALTY

STANDARD DUTY

STANDARD DUTY	EPA Eng./Test Weight
2-WAY	5.9L, 5500 lbs
3-WAY	5.9L, 5500 lbs
3-WAY, w/Air	5.9L, 5500 lbs

Round - w/o Air Tube

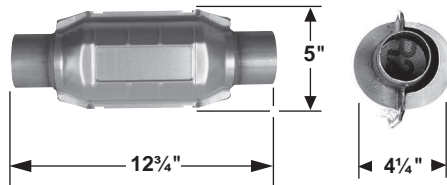

INLET/I.D.

OUTLET/I.D.

602213	1-3/4"	1-3/4" w/o air tube
602214	2"	2" w/o air tube
602215	2-1/4"	2-1/4" w/o air tube, 13" OAL
602216	2-1/2"	2-1/2" w/o air tube, 13" OAL

Oval - w/o Air Tube

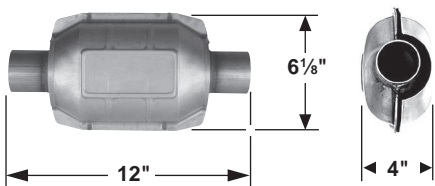

INLET/I.D.

OUTLET/I.D.

602295	2-1/4"	2-1/4"
602296	2-1/2"	2-1/2"

CATALYTIC CONVERTERS

602*** SPECIALITY - Pre-OBdII

EPA Pre-OBdII BY DESIGN

Made to keep the "Light Off" (MIL check engine light).

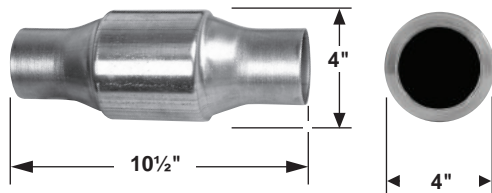

SPUN BODY	EPA Eng./Test Weight
2-WAY	5.9L, 6000 lbs
3-WAY	5.9L, 6000 lbs
3-WAY, w/Air	5.9L, 6000 lbs

	INLET/I.D.	OUTLET/I.D.
602384	2"	2"
602385	2-1/4"	2-1/4"
602386	2-1/2"	2-1/2"
602387	3"	3"

6025** Series

ENHANCED STANDARD DUTY

Oval - w/Air Tube

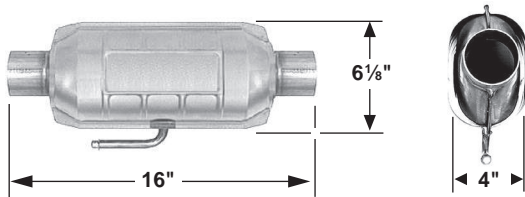

ENHANCED STANDARD DUTY	EPA Eng./Test Weight
2-WAY	5.9L, 6515 lbs
3-WAY	5.9L, 6515 lbs
3-WAY, w/Air	5.9L, 6515 lbs

	INLET/I.D.	OUTLET/I.D.
602534	2"	2" w/air tube
602535	2-1/4"	2-1/4" w/air tube
602536	2-1/2"	2-1/2" w/air tube
602537	3"	3" w/air tube

Can be used as alternate converters to 602000, 602200 and 602500 Series converters.

Oval - w/o Air Tube

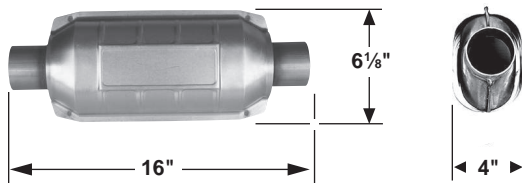

	INLET/I.D.	OUTLET/I.D.
602543	1-3/4"	1-3/4" w/o air tube
602544	2"	2" w/o air tube
602545	2-1/4"	2-1/4" w/o air tube
602546	2-1/2"	2-1/2" w/o air tube
602547	3"	3" w/o air tube

Can be used as alternate converters to 602000, 602200 and 602500 Series converters.

CATALYTIC CONVERTERS

603*** Series

MEDIUM DUTY

MEDIUM DUTY	EPA Eng./Test Weight
2-WAY	5.9L, 5500 lbs
3-WAY	5.9L, 5500 lbs
3-WAY, w/Air	5.9L, 5500 lbs

Oval - w/Air Tube

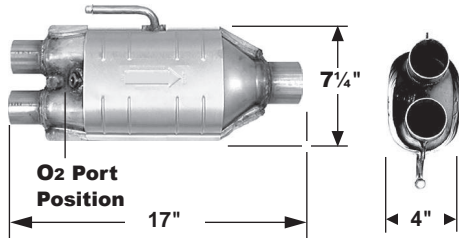

	INLET/I.D.	OUTLET/I.D.
603040	2" Dual Inlets w/O2 Sensor port	2-1/2" w/air tube

Oval - w/o Air Tube

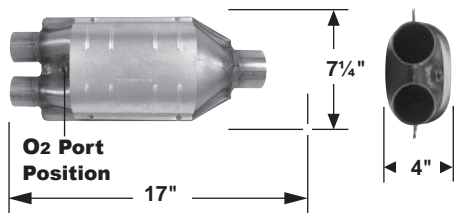

	INLET/I.D.	OUTLET/I.D.
603240	2" Dual, w/O2 Sensor port	2-1/2"

6040** Series

HEAVY DUTY

HEAVY DUTY	EPA Eng./Test Weight
2-WAY	7.7L, 7000 lbs
3-WAY	7.5L, 7000 lbs

Oval - w/o Air Tube

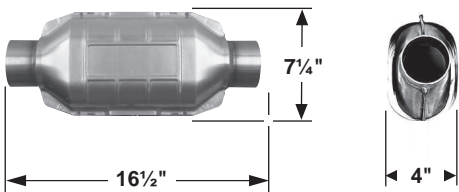

	INLET/I.D.	OUTLET/I.D.
604006	2-1/2"	2-1/2"
604007	3"	3"

6050** Series

HEAVY DUTY

HEAVY DUTY	EPA Eng./Test Weight
2-WAY	7.7L, 7000 lbs
3-WAY	7.5L, 7000 lbs
3-WAY, w/Air	7.5L, 7000 lbs

Oval - w/Air Tube

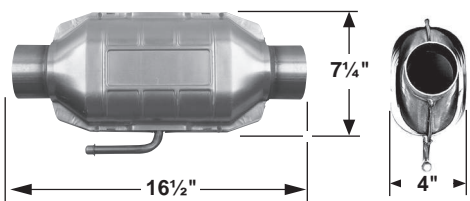

	INLET/I.D.	OUTLET/I.D.
605006	2-1/2"	2-1/2"
605007	3"	3"

CATALYTIC CONVERTERS

6060** Series

SUPER DUTY

SUPER DUTY	EPA Eng./GVWR
2-WAY	7.5L, 15000 lbs or less
3-WAY	7.5L, 15000 lbs or less

Oval - w/o Air Tube

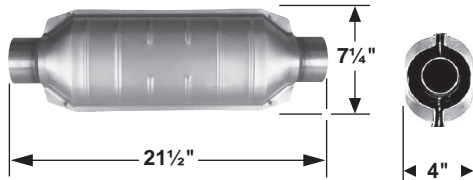

	INLET/I.D.	OUTLET/I.D.
606007	3"	3" w/o air tube

6070** Series

SUPER DUTY

SUPER DUTY	EPA Eng./GVWR
2-WAY	7.5L, 15000 lbs or less
3-WAY	7.5L, 15000 lbs or less
3-WAY, w/Air	7.5L, 15000 lbs or less

Oval - w/Air Tube

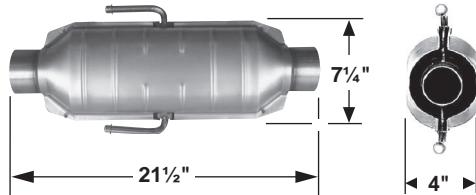

	INLET/I.D.	OUTLET/I.D.
607007	3"	3" w/Dual air tubes

6063**/6074** Series

TORPEDO - OEM Style Ford Truck Converters

Torpedo Series	EPA Eng./GVWR
3-WAY	8.3L, 14,000 lbs
3-WAY w/Air	8.3L, 14,000 lbs

Round - w/o Air Tube

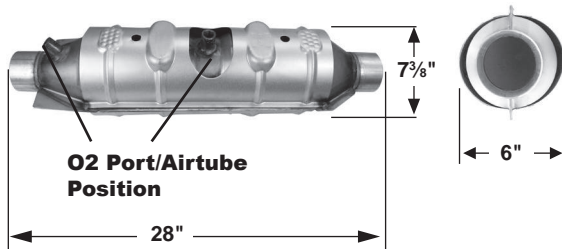

	INLET/I.D.	OUTLET/I.D.
606307	3"	3" w/o O2 Sensor port/Airtubes
607407	3"	3" w/O2 Sensor port/Airtubes

CATALYTIC CONVERTERS

608*** Series OBDII Vehicles up to LEV

EPA OBDII BY DESIGN

Made to keep the "Light Off" (MIL check engine light).

EPA OBD II

EPA Eng./Test Weight

3-WAY	5.9L, 6250 lbs
3-WAY w/Air	5.9L, 6250 lbs

Oval - w/o Air Tube

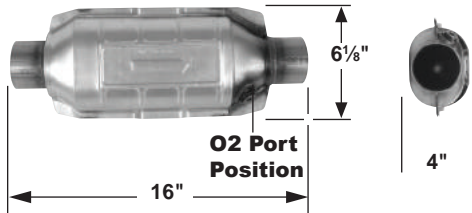

Units have O2 Sensor port in Outlet, unless otherwise noted

	INLET/I.D.	OUTLET/I.D.
608204	2"	2" w/O2 Sensor port
608205	2-1/4"	2-1/4" w/O2 Sensor port
608206	2-1/2"	2-1/2" w/O2 Sensor port

Round - w/o Air Tube

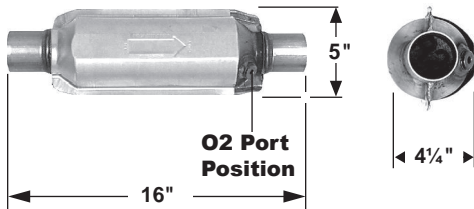

Units have O2 Sensor port in Outlet, unless otherwise noted

	INLET/I.D.	OUTLET/I.D.
608214	2"	2" w/O2 Sensor port
608215	2-1/4"	2-1/4" w/O2 Sensor port
608216	2-1/2"	2-1/2" w/O2 Sensor port
608217	3"	3" w/O2 Sensor port

Oval - w/o Air Tube

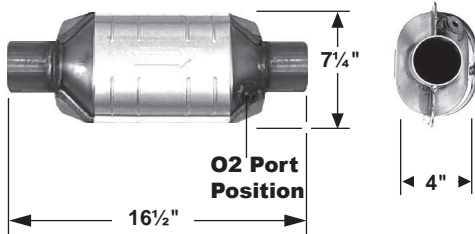

INLET/I.D. OUTLET/I.D.

608224	2"	2" w/O2 Sensor port
608225	2-1/4"	2-1/4" w/O2 Sensor port
608226	2-1/2"	2-1/2" w/O2 Sensor port
608227	3"	3" w/O2 Sensor port

Oval - w/o Air Tube

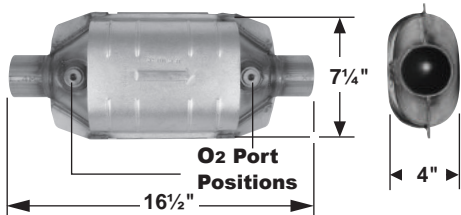

INLET/I.D. OUTLET/I.D.

608234	2"	2" w/Two O2 Sensor ports
608235	2-1/4"	2-1/4" w/Two O2 Sensor ports

CATALYTIC CONVERTERS

608*** Series - (cont.) OBDII Vehicles up to LEV

EPA OBDII BY DESIGN

Made to keep the "Light Off" (MIL check engine light).

EPA OBD II	EPA Eng./Test Weight
3-WAY	5.9L, 6250 lbs
3-WAY w/Air	5.9L, 6250 lbs

Oval - w/Air Tube

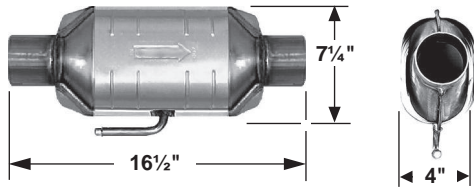

	INLET/I.D.	OUTLET/I.D.
608006	2-1/2"	2-1/2" w/air tube

Oval - w/o Air Tube

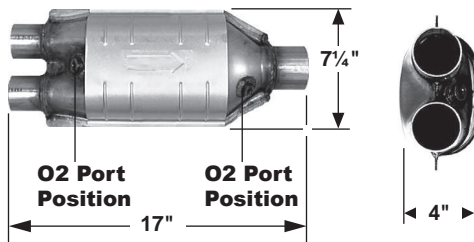

	INLET/I.D.	OUTLET/I.D.
608240	2" Dual	2-1/2" w/Two O2 Sensor ports

Round - w/o Air Tube

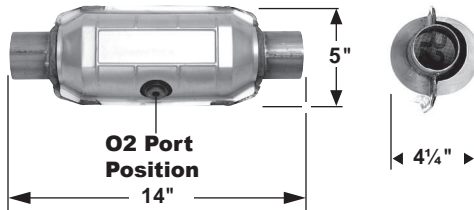

	INLET/I.D.	OUTLET/I.D.
608254	2"	2" w/O2 sensor port at middle of shell
608255	2-1/4"	2-1/4" w/O2 sensor port at middle of shell
608256	2-1/2"	2-1/2" w/O2 sensor port at middle of shell

Oval - w/o Air Tube

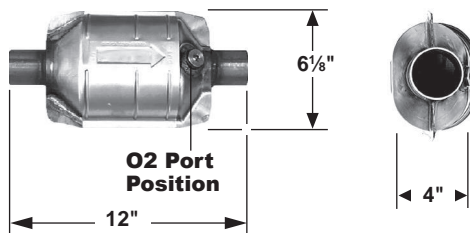

	INLET/I.D.	OUTLET/I.D.
608294	2"	2" w/O2 Sensor port
608295	2-1/4"	2-1/4" w/O2 Sensor port

CATALYTIC CONVERTERS

608*** Series OBDII Vehicles up to LEV

EPA OBDII BY DESIGN

Made to keep the "Light Off" (MIL check engine light).

EPA OBD II	EPA Eng./Test Weight
2-WAY	5.9L, 5500 lbs
3-WAY	5.9L, 5500 lbs

Round - No Necks, w/o Air Tube

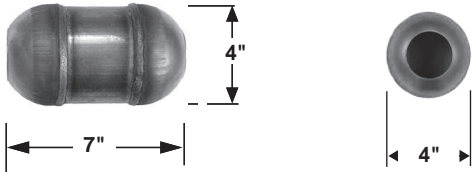

	INLET/I.D.	OUTLET/I.D.
608364	2"	2"
608365	2-1/4"	2-1/4"
608366	2-1/2"	2-1/2"

Round - No Necks, w/o Air Tube

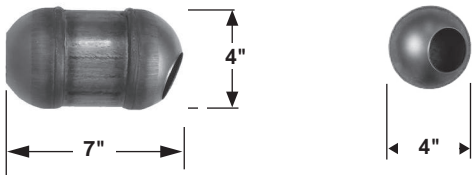

	INLET/I.D.	OUTLET/I.D.
608374	2" Angled	2"
608375	2-1/4" Angled	2-1/4"
608376	2-1/2" Angled	2-1/2"

608*** Series OBDII Vehicles up to LEV

EPA OBDII BY DESIGN

Made to keep the "Light Off" (MIL check engine light).

EPA OBD II	EPA Eng./Test Weight
3-WAY	5.9L, 6000 lbs
3-WAY w/Air	5.9L, 6000 lbs

Spun Body one-piece design Round - w/o Air Tube

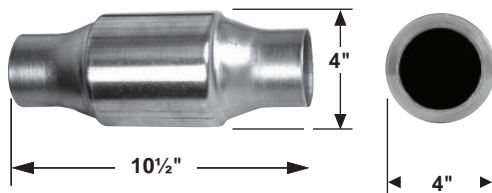

	INLET/I.D.	OUTLET/I.D.
608384	2"	2"
608385	2-1/4"	2-1/4"
608395	2-1/4"	2-1/4" w/O ₂ Sensor Fitting
608386	2-1/2"	2-1/2"
608396	2-1/2"	2-1/2" w/O ₂ Sensor Fitting
608387	3"	3"
608397	3"	3" w/O ₂ Sensor Fitting

CATALYTIC CONVERTERS

608*** Series LEVII and Cleaner Applications

EPA OBD II	EPA Eng./Test Weight
3-WAY	5.9L, 6250 lbs
3-WAY w/Air	5.9L, 6250 lbs

EPA OBDII BY DESIGN

These parts utilize a higher precious metal loading for LEVII and cleaner emission standards.

Round - w/o Air Tube

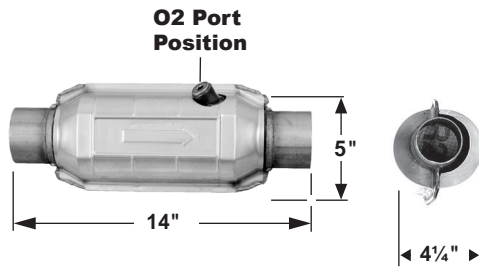

	INLET/I.D.	OUTLET/I.D.
608264	2"	2" w/O2 Sensor port
608265	2-1/4"	2-1/4" w/O2 Sensor port
608266	2-1/2"	2-1/2" w/O2 Sensor port

Special Body - Angled Inlet and Outlet, w/o Air Tube

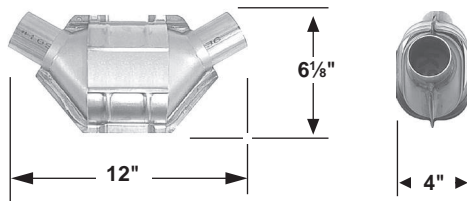

	INLET/I.D.	OUTLET/I.D.
608274	2"	2"
608275	2-1/4"	2-1/4"
608276	2-1/2"	2-1/2"

Special Body - Angled Inlet, w/o Air Tube

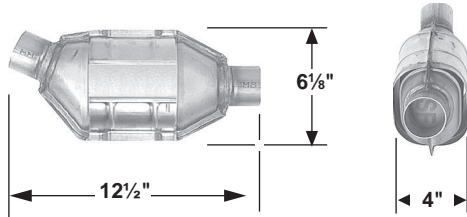

	INLET/I.D.	OUTLET/I.D.
608284	2"	2"
608285	2-1/4"	2-1/4"
608286	2-1/2"	2-1/2"

Round - w/o Air Tube

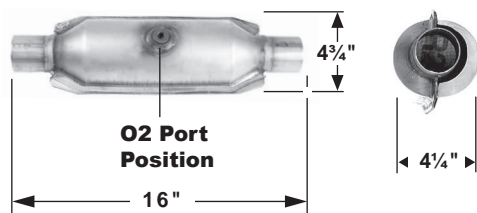

	INLET/I.D.	OUTLET/I.D.
608314	2"	2" w/O2 sensor port at middle of shell
608315	2-1/4"	2-1/4" w/O2 sensor port at middle of shell

CATALYTIC CONVERTERS

608*** Series - (cont.) LEV II and Cleaner Applications

EPA OBDII BY DESIGN

These parts utilize a higher precious metal loading for LEV II and cleaner emission standards.

EPA OBD II	EPA Eng./Test Weight
3-WAY	5.9L, 6250 lbs
3-WAY w/Air	5.9L, 6250 lbs

Round - w/o Air Tube

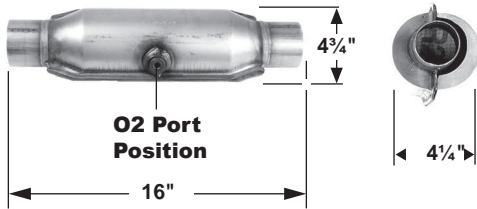

	INLET/I.D.	OUTLET/I.D.
608316	2-1/2"	2-1/2" w/O2 sensor port at middle of shell

Round - w/o Air Tube

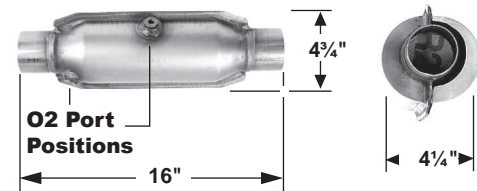

	INLET/I.D.	OUTLET/I.D.
608326	2-1/2"	2-1/2" w/Two O2 sensor ports, one at middle of shell & one at left top inlet

Oval - w/o Air Tube

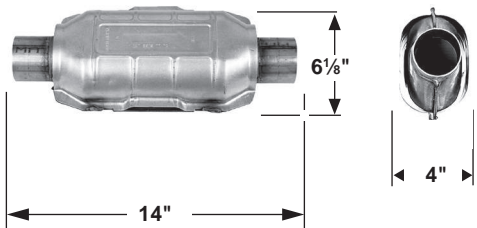

	INLET/I.D.	OUTLET/I.D.
608404	2"	2"
608405	2-1/4"	2-1/4"
608406	2-1/2"	2-1/2"
608407	3"	3"

Round - w/o Air Tube

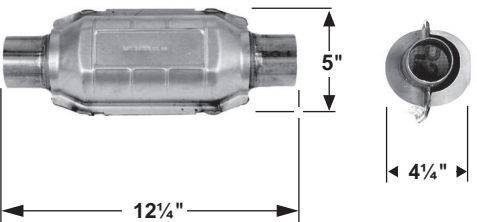

	INLET/I.D.	OUTLET/I.D.
608414	2"	2"
608415	2-1/4"	2-1/4"
608416	2-1/2"	2-1/2"
608417	3"	3"

CATALYTIC CONVERTERS

608*** Series - (cont.) LEVII and Cleaner Applications

EPA OBDII BY DESIGN

These parts utilize a higher precious metal loading for LEVII and cleaner emission standards.

EPA OBD II	EPA Eng./Test Weight
3-WAY	5.9L, 6250 lbs
3-WAY w/Air	5.9L, 6250 lbs

Oval - w/o Air Tube

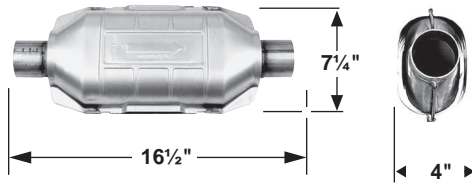

	INLET/I.D.	OUTLET/I.D.
608434	2"	2"
608435	2-1/4"	2-1/4"
608436	2-1/2"	2-1/2"
608437	3"	3"

6088** Series - LEVII and Cleaner Applications

EPA OBDII BY DESIGN

These parts utilize a higher precious metal loading for LEVII and cleaner emission standards.

EPA OBD II	EPA Eng./Test Weight
3-WAY	5.9L, 6250 lbs
3-WAY w/Air	5.9L, 6250 lbs

Spun Units

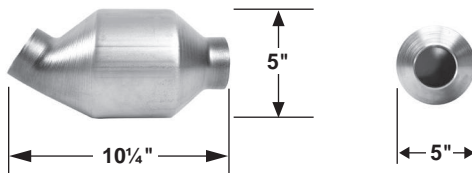

	INLET/I.D.	OUTLET/I.D.
608824	2"	2"
608825	2-1/4"	2-1/4"
608826	2-1/2"	2-1/2"

CATALYTIC CONVERTERS

SELECT+PLUS TechSeries ULEV and Cleaner Applications

Contains approximately 40% higher precious metal content than most aftermarket brands.

EPA OBD II

EPA Eng./Test Weight

3-WAY

5.9L, 6500 lbs

Round - w/o Air Tube

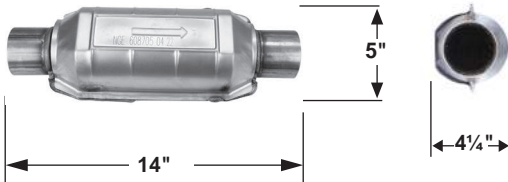

INLET/I.D.

OUTLET/I.D.

608704	2"	2"
608705	2-1/4"	2-1/4"
608706	2-1/2"	2-1/2"

Round - w/o Air Tube

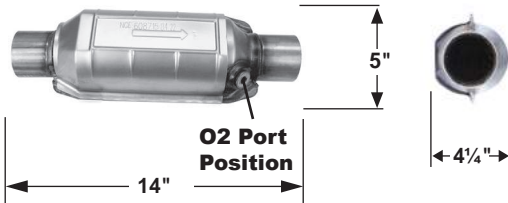

INLET/I.D.

OUTLET/I.D.

608714	2"	2"
608715	2-1/4"	2-1/4"
608716	2-1/2"	2-1/2"

Round - w/o Air Tube



INLET/I.D.

OUTLET/I.D.

608734	2"	2"
608735	2-1/4"	2-1/4"
608736	2-1/2"	2-1/2"
608737	3"	3"

Round - w/o Air Tube

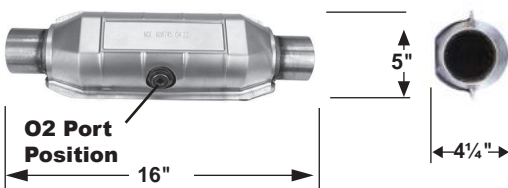

INLET/I.D.

OUTLET/I.D.

608744	2"	2"
608745	2-1/4"	2-1/4"
608746	2-1/2"	2-1/2"
608747	3"	3"

Round - w/o Air Tube

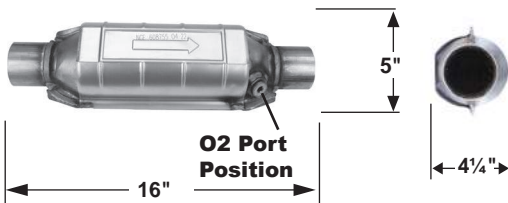

INLET/I.D.

OUTLET/I.D.

608754	2"	2"
608755	2-1/4"	2-1/4"
608756	2-1/2"	2-1/2"
608757	3"	3"

CATALYTIC CONVERTERS

SUPER SELECT+ TechSeries

Advanced wash coat technology & enhanced metal loading.

EPA OBD II	EPA Eng./Test Weight
3-WAY	6.2L, 9,000 lbs

Round - w/o Air Tube

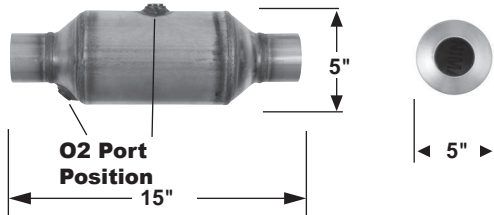

	INLET/I.D.	OUTLET/I.D.
608894	2"	2"
608895	2-1/4"	2-1/4"
608896	2-1/2"	2-1/2"
608897	3"	3"

6090** Series

LARGE BODY SUPER X DUTY

SPECIAL	EPA Eng./Test Weight
2-WAY	5.9L, 6515 lbs
3-WAY	5.9L, 6515 lbs
3-WAY, w/Air	5.9L, 6515 lbs

Oval - w/Air Tube

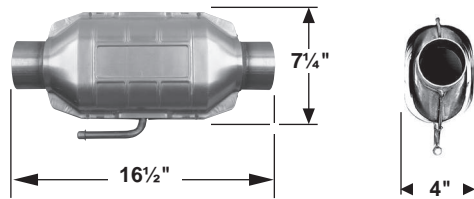

	INLET/I.D.	OUTLET/I.D.
609004	2"	2" w/air tube
609005	2-1/4"	2-1/4" w/air tube
609006	2-1/2"	2-1/2" w/air tube

Oval - w/o Air Tube

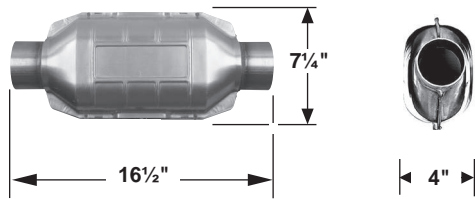

	INLET/I.D.	OUTLET/I.D.
609007	3"	3" w/o air tube

Oval

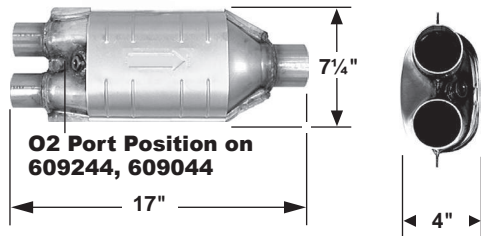

	INLET/I.D.	OUTLET/I.D.
609244	2" Dual, w/O ₂ Sensor port	2-1/2" w/o air tube
609044	2" Dual, w/O ₂ Sensor port	2-1/2" w/air tube

ACURA

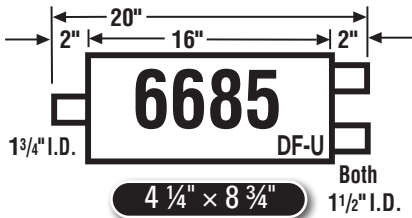

86-89 Integra

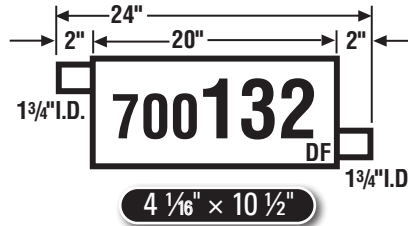

90-93 Integra

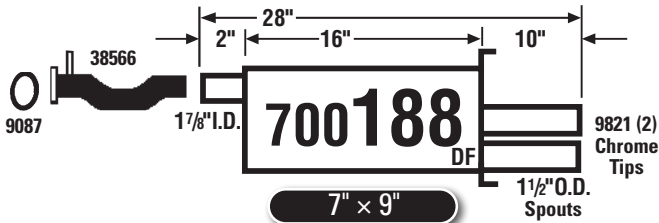

97-99 CL, 4 cyl.

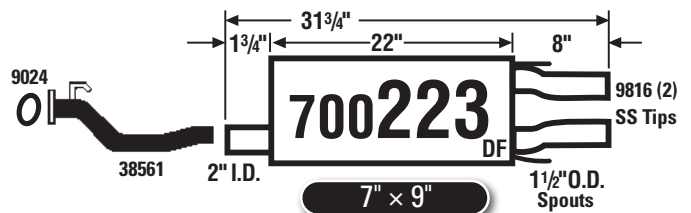

92-94 Vigor
95-98 TL

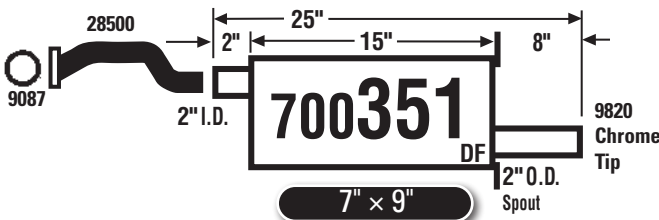

94-01 Integra RS, LS, GS, 3-Dr.

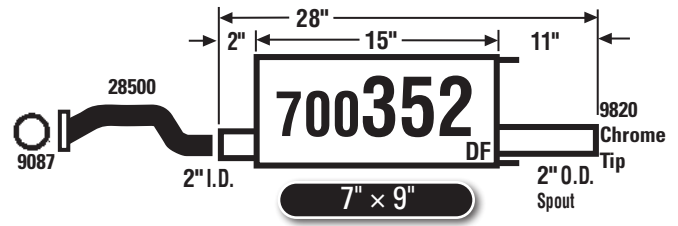

94-01 Integra RS, LS, GS, 4-Dr.

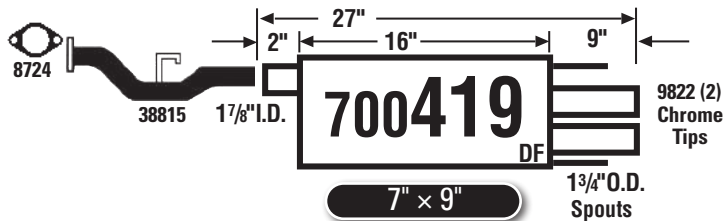

97-99 CL, 6 cyl.

NOTE: Black area denotes welded head bracket.

DF-U - Denotes muffler used primarily as Direct Fit, but is also Universal.

U-DF - Denotes muffler used primarily as Universal, but is also Direct Fit.

DF - Direct Fit Muffler

U - Universal Muffler

HS - Denotes Heat Shield is on muffler.

DIRECT FITS

MAXIMUM **TMSL**

CHRYSLER / DODGE / PLYMOUTH / RAM

MSL MUFFLER BY APPLICATION

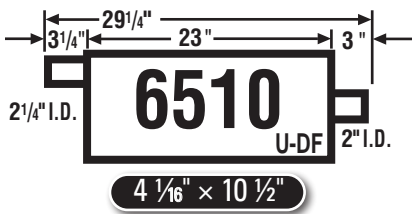

- 65-74 Fury, Monaco, Polara
- 65-73 Custom 880, Monaco, Polara (Front)
- 65-72 Custom 880, Imperial, Newport, New Yorker, Dual Exh.
- 65-67 Newport, New Yorker

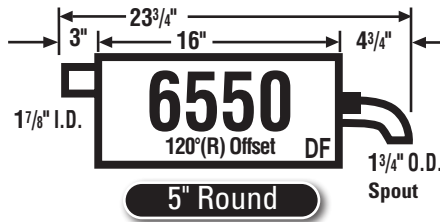

- 81-88 600, Caravelle
- 83-87 New Yorker
- 82-86 LeBaron, Town & Country
- 81-86 Aries
- 81-86 Reliant, Reliant America
- 81-85 400



- 81-90 Omni, Horizon
- 83-87 Charger, Turismo
- 82-84 Rampage, Scamp

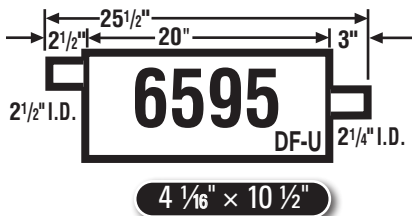

- 80-89 AD, AW, PD, PW Series

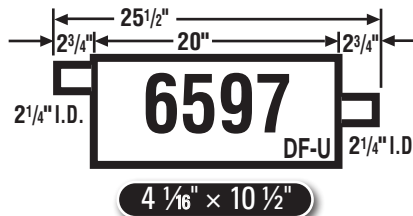

- 79-80 Chry. Full Size
- 75-79 Cordoba, Magnum
- 67-80 Dod./Plym. Full Size
- 75-78 Fury, Fury Custom, Roadrunner
- 74-76 Satellite, Roadrunner
- 69-73 Belvedere, Roadrunner, Satellite
- 1967 Belvedere, Satellite

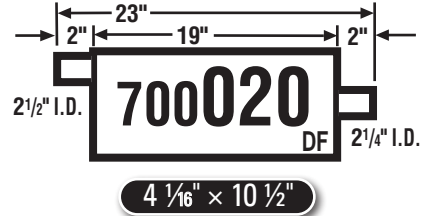

- 1990 Dakota



- 89-95 Acclaim, Spirit
- 90-94 LeBaron, 4-Dr. Sedan

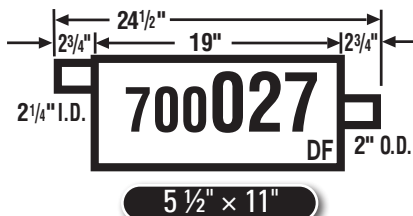

- 91-95 Caravan, Voyager, Town & Country

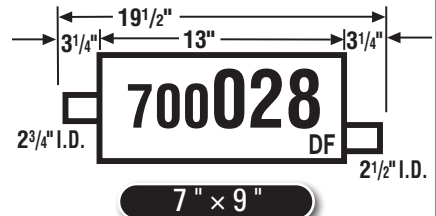

- 92-93 Dakota, D150/250, W150/250 Ramcharger

NOTE: Black area denotes welded head bracket.

DF-U - Denotes muffler used primarily as Direct Fit, but is also Universal.
 U-DF - Denotes muffler used primarily as Universal, but is also Direct Fit.

DF - Direct Fit Muffler
 U - Universal Muffler
 HS - Denotes Heat Shield is on muffler.

CHRYSLER / DODGE / PLYMOUTH / RAM

MSL MUFFLER BY APPLICATION

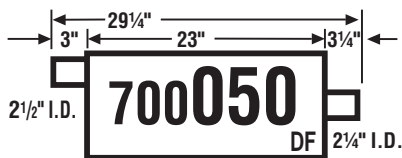

4 1/16" × 10 1/2"

- 75-78** Newport, New Yorker, Imperial, Town & Country
- 88-89** D100/150/250, W100/150
- 79-89** Series D, W, AD, AW/PD, PW, Ramcharger, Trail Duster
- 75-87** Series B, C, P, CB, MB, Vans, Wagons

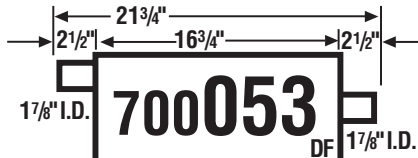

4 1/4" × 8 3/4"

- 82-89** New Yorker, 5th Avenue
- 80-83** Cordoba, Imperial (81-83)
- 79-81** Newport (79-80), New Yorker (1979), LeBaron, Town & Country (79-80)
- 79-89** Diplomat, Mirada (80-89), St. Regis (1979)
- 76-80** Aspen (exc. 1978)
- 82-89** Gran Fury
- 76-80** Volare (exc. 1978)

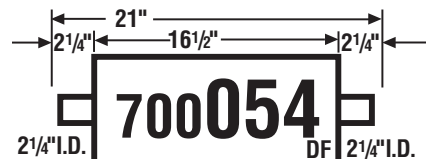

4" Round

- 1993** Imperial, New Yorker, 5th Avenue

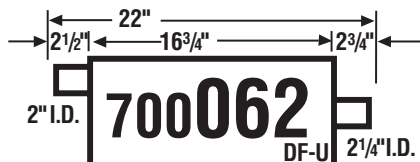

4 1/4" × 8 3/4"

- 79-87** Series B, D, W, PB, CB300/350, MB300, PD100, PW100
- 79-80** AD100, AW100

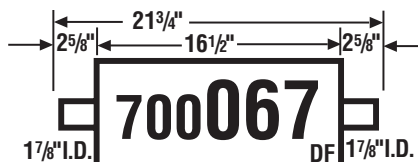

4" Round

- 82-90** LeBaron, New Yorker (83-87), E-Class (83-84), Town & Country (82-88)
- 89-90** Spirit (exc. turbo)
- 82-88** 400 (82-83), 600, Aries, Aries America
- 89-90** Acclaim (exc. Turbo)
- 83-88** Caravelle (85-88), Reliant, Reliant America
- 85-90** Omni, Horizon (Canada)

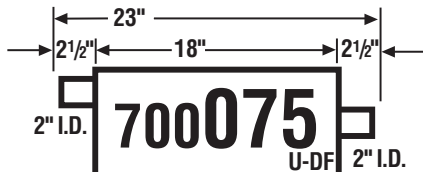

4 1/16" × 10 1/2"

- 87-96** Dakota 4 cyl.
- 87-89** Dakota 6 cyl.

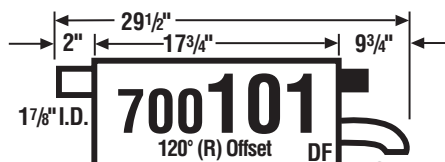

5" Round

- 89-90** LeBaron Coupe, Convertible, (exc. turbo)
- 87-88** LeBaron, Town & Country
- 87-88** Aries, Aries America
- 87-88** Reliant, Reliant America

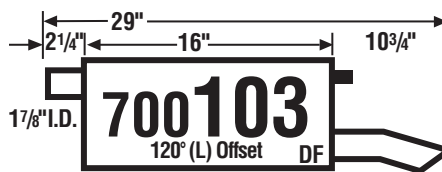

6" Round

- 87-94** Shadow, Shadow America (exc. turbo)
- 87-94** Sundance, Sundance America (exc. turbo)
- 1992** Duster

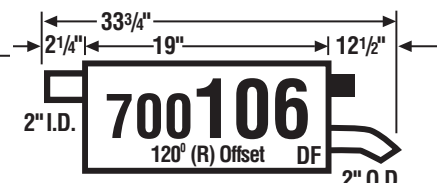

6" Round

- 90-93** New Yorker, Landau, Salon, 5th Avenue, Imperial
- 88-89** New Yorker
- 88-93** Dynasty

NOTE: Black area denotes welded head bracket.

DF-U - Denotes muffler used primarily as Direct Fit, but is also Universal.

U-DF - Denotes muffler used primarily as Universal, but is also Direct Fit.

DF - Direct Fit Muffler
U - Universal Muffler

HS - Denotes Heat Shield is on muffler.

DIRECT FITS

MAXIMUM **TMSL**

CHRYSLER / DODGE / PLYMOUTH / RAM

MSL MUFFLER BY APPLICATION

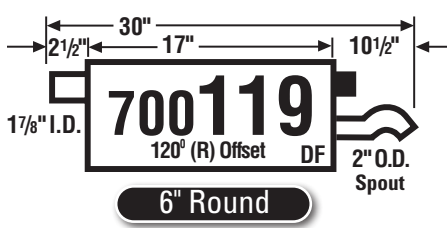

90-95 LeBaron Coupe, Conv.

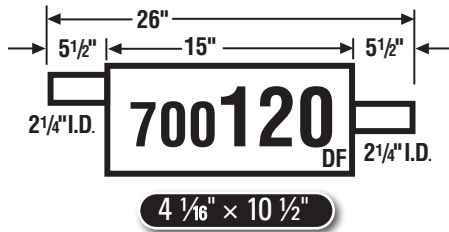

1992 B250/350
89-91 B150/250/350

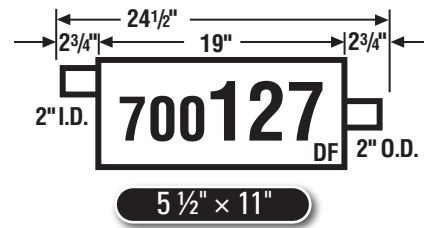

91-95 Caravan, Voyager

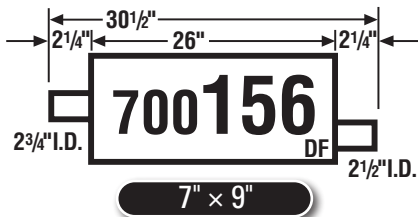

92-94 B150/250

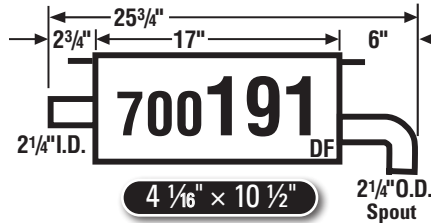

95-99 Neon

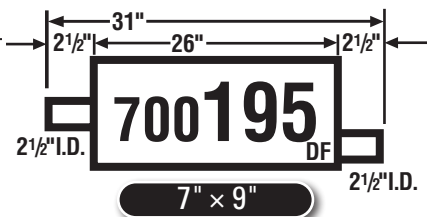

94-97 B150/250

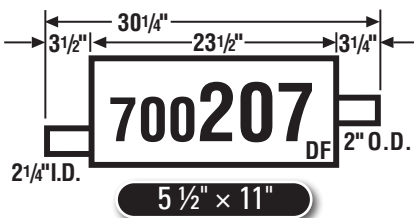

91-95 Town & Country, Grand Caravan, Grand Caravan C/V, Grand Voyager



94-97 R1500, R2500

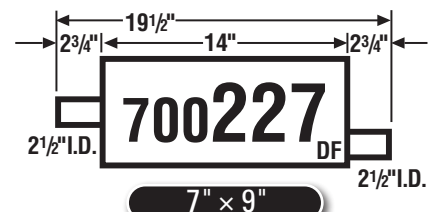

94-96 Dakota

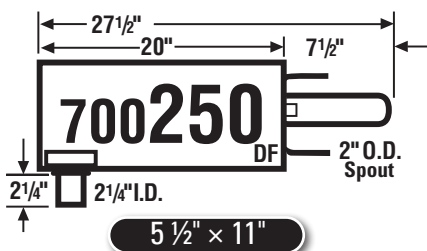

96-97 Cirrus
95-97 Stratus, Breeze

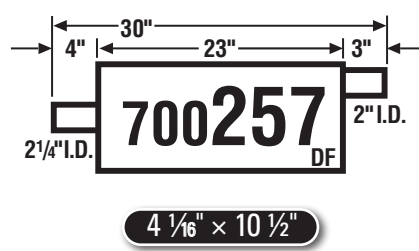

96-07 Town & Country, Caravan, Voyager, Grand Caravan, Grand Voyager

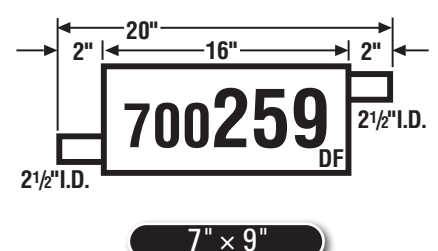

97-99 Dakota

NOTE: Black area denotes welded head bracket.

DF-U - Denotes muffler used primarily as Direct Fit, but is also Universal.

U-DF - Denotes muffler used primarily as Universal, but is also Direct Fit.

DF - Direct Fit Muffler

U - Universal Muffler

HS - Denotes Heat Shield is on muffler.

CHRYSLER / DODGE / PLYMOUTH / RAM

ORDER BY APPLICATION

MSL

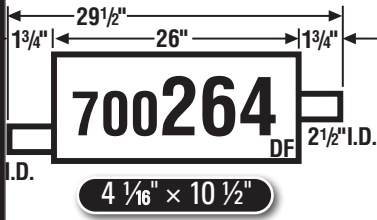

76-78 B100, BF100, B200, BF200, B300, BF300, CB300, MB300, MB400, PB100, PB200, PB300

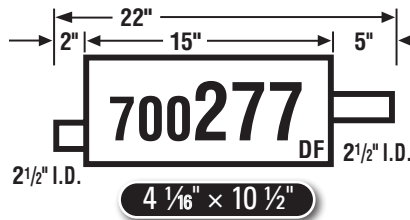

1991 Dakota

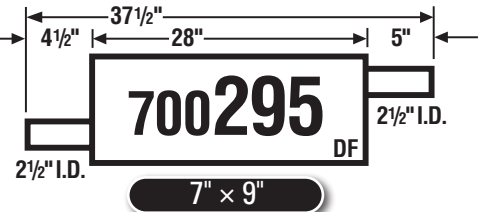

98-02 Series R1500

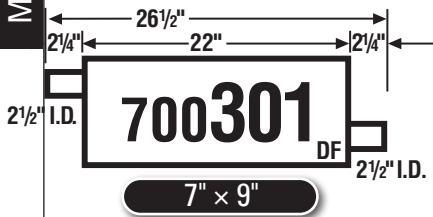

98-03 Series B150

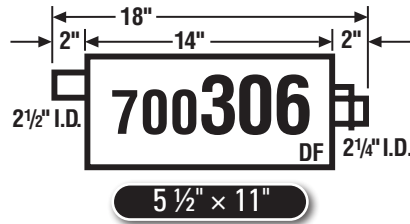

98-02 Concorde (Rear)
98-04 Intrepid (Rear)

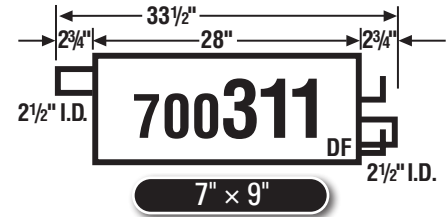

98-03 Durango



88-93 D250, D350 Turbo Diesel Eng.
88-93 W250, W350 Turbo Diesel Eng.

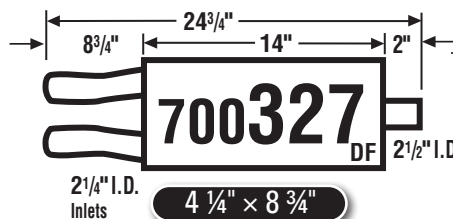

99-04 300M (Front)
98-04 Concorde, Intrepid, 3.2L & 3.5L (Front)
99-01 LHS (Front)

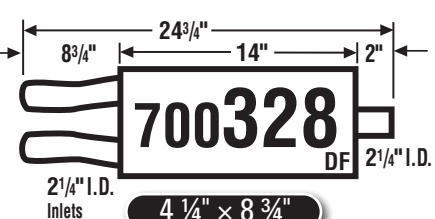

98-04 Concorde, Intrepid, 2.7L (Front)

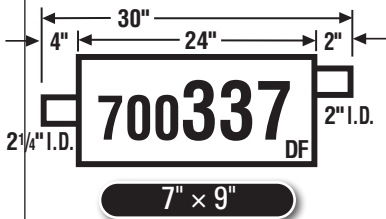

96-07 Caravan, Voyager 4 cyl.
96-00 Grand Caravan, Grand Voyager 4 cyl.



01-05 Town & Country, Grand Caravan, Grand Voyager 6 cyl., 3.8L

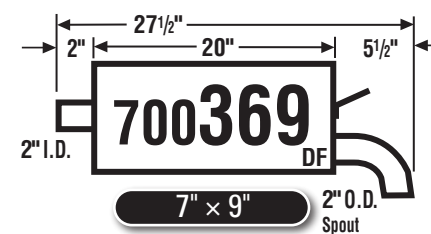

00-05 Neon

NOTE: Black area denotes welded head bracket.

DF-U - Denotes muffler used primarily as Direct Fit, but is also Universal.

U-DF - Denotes muffler used primarily as Universal, but is also Direct Fit.

DF - Direct Fit Muffler

U - Universal Muffler

HS - Denotes Heat Shield is on muffler.

CHRYSLER / DODGE / PLYMOUTH / RAM

MSL MUFFLER BY APPLICATION

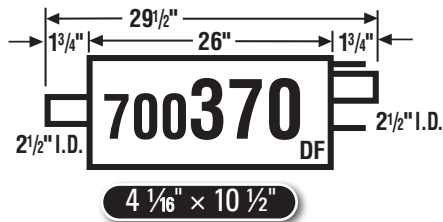

00-03 Durango 8 cyl.

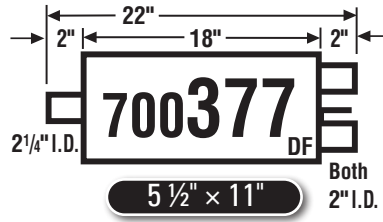

96-00 Sebring Convertible

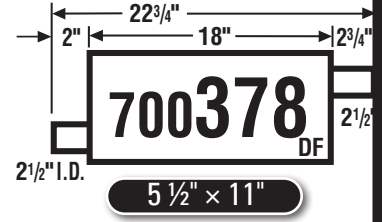

99-04 300M (Center)
98-04 Concorde, Intrepid 3.2L & 3.5L (Center)
99-01 LHS (Center)

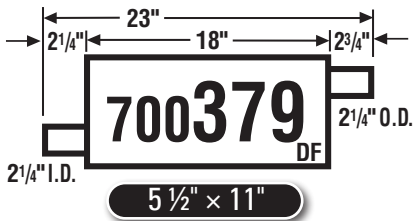

98-04 Concorde, Intrepid, 2.7L (Center)

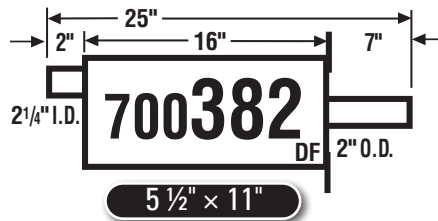

98-00 Cirrus, Breeze
01-06 Sebring (Sedan)
98-06 Stratus (Sedan)

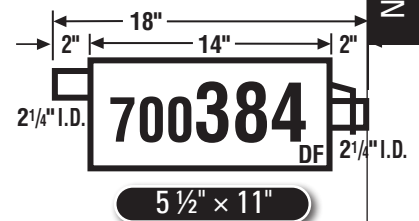

98-04 Concorde, Intrepid, 2.7L (Rear)

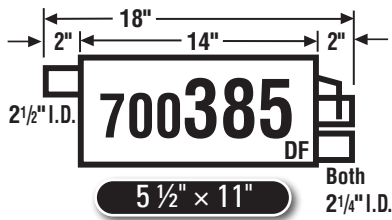

99-04 300M (Rear)
02-04 Concorde Limited, 3.5L (Rear)
99-01 LHS (Rear)

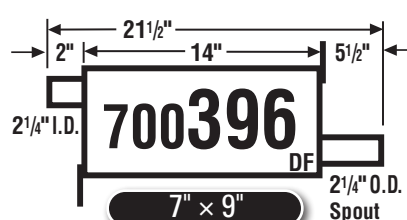

01-10 PT Cruiser (exc. Turbo)



95-97 Cirrus, Stratus, 6 cyl.

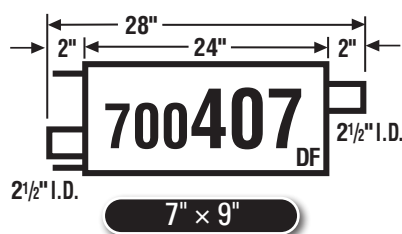

00-03 Dakota, 112" W.B., 131" W.B. Club Cab

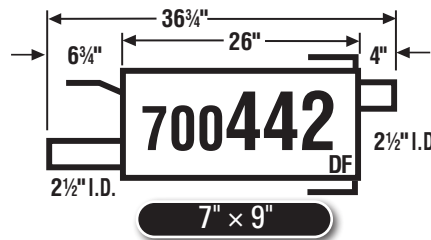

02-05 R1500 Ram Pickup

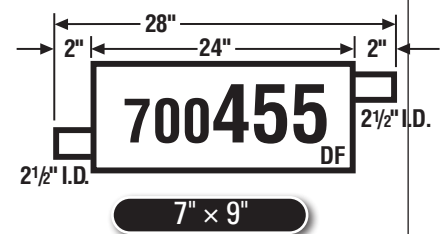

00-03 Dakota Quad Cab, 3.9L
00-03 Dakota Quad Cab, 5.9L

NOTE: Black area denotes welded head bracket.

DF-U - Denotes muffler used primarily as Direct Fit, but is also Universal.

U-DF - Denotes muffler used primarily as Universal, but is also Direct Fit.

DF - Direct Fit Muffler

U - Universal Muffler

HS - Denotes Heat Shield is on muffler.

CHRYSLER / DODGE / PLYMOUTH / RAM

MSL MUFFLER BY APPLICATION

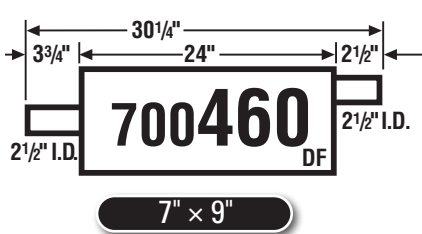

- 2004 Dakota, Dakota Club & Quad Cab, 3.7L
- 2004 Dakota, Dakota Club & Quad Cab, 4.7L

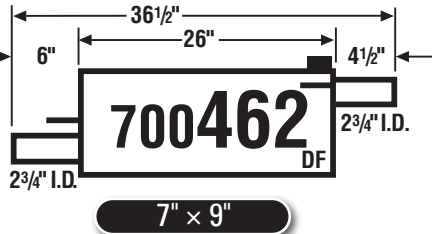

- 04-05 R1500, 5.7L Hemi

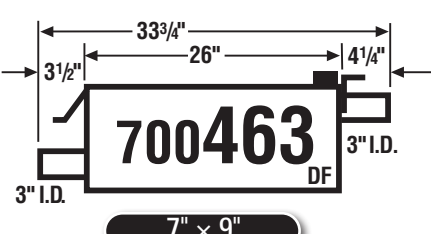

- 2003 R1500, 5.7L Hemi

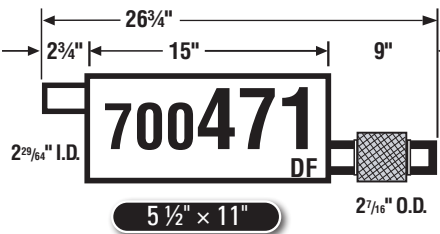

- 04-06 Chrysler, Pacifica, V6-3.5L, Front Muffler

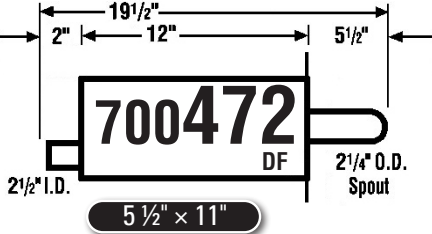

- 04-06 Chrysler, Pacifica, V6-3.5L, Rear Muffler

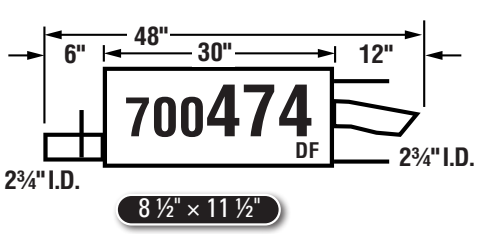

- 2007 Chrysler, Aspen, V8-4.7L
- 2007 Chrysler, Aspen, V8-5.7L
- 04-09 Dodge, Durango, V6-3.7L
- 04-07 Dodge, Durango, V8-4.7L
- 04-07 Dodge, Durango, V8-5.7L

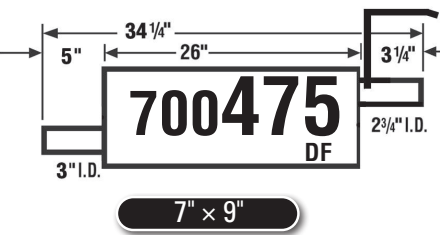

- 06-08 Dodge, Ram 1500, V6-3.7L
- 06-08 Dodge, Ram 1500, V8-4.7L

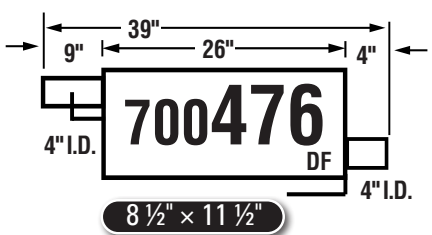

- 05-09 Dodge, Ram 2500, L6-5.9L
- 05-07 Dodge, Ram 3500, L6-5.9L

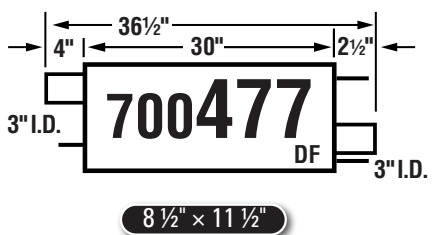

- 06-08 Dodge, Ram 1500, V8-5.7L

NOTE: Black area denotes welded head bracket.

DF-U - Denotes muffler used primarily as Direct Fit, but is also Universal.
 U-DF - Denotes muffler used primarily as Universal, but is also Direct Fit.

DF - Direct Fit Muffler
 U - Universal Muffler
 HS - Denotes Heat Shield is on muffler.

DIRECT FITS

MAXIMUM **TMSL**

CHRYSLER / DODGE / PLYMOUTH / RAM

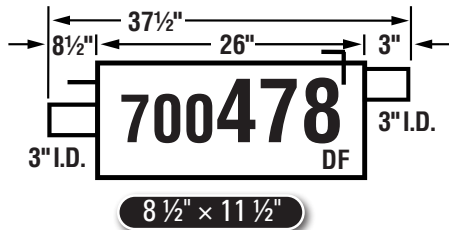

- 03-09 Dodge, Ram 2500, V8-5.7L
- 03-08 Dodge, Ram 3500, V8-5.7L

*Challenge PN: 2558

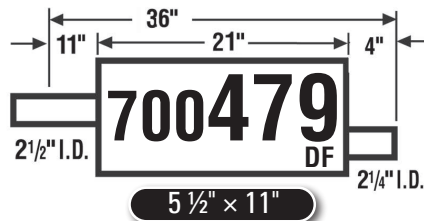

- 07-11 Dodge, Nitro, V6-3.7L
- 08-12 Jeep, Liberty, V6-3.7L

*Challenge PN: 2564

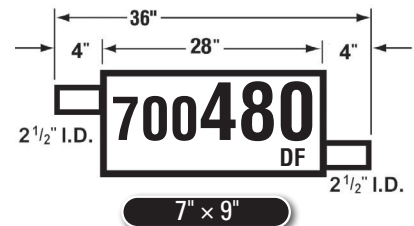

- 05-10 Dodge, Dakota, V6-3.7L
- 05-10 Dodge, Dakota, V8-4.7L
- 06-09 Mitsubishi, Raider, V6-3.7L
- 06-07 Mitsubishi, Raider, V8-4.7L
- 2011 Ram, Dakota, V6-3.7L
- 2011 Ram, Dakota, V8-4.7L

FORD / LINCOLN / MERCURY

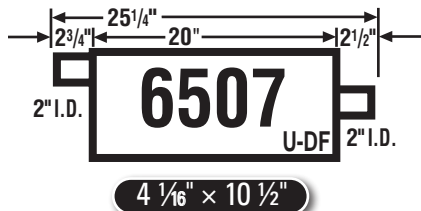

- 1974 Ranchero, Torino Sta. Wag.
- 72-74 Fairlane, Montego, Torino
- 65-72 Custom, Galaxie
- 1966 Comet, Fairlane, All Models

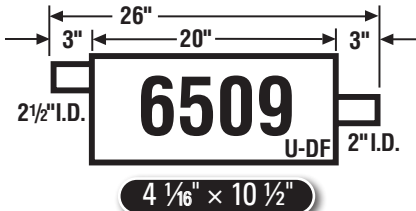

- 72-76 Ford/Merc. Full Size

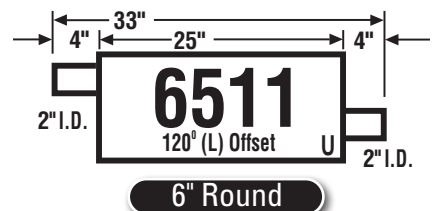

- 61-79 F100 thru F250

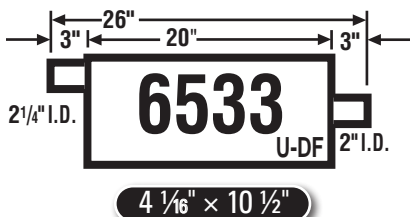

- 67-78 Ford/Merc. Full Size

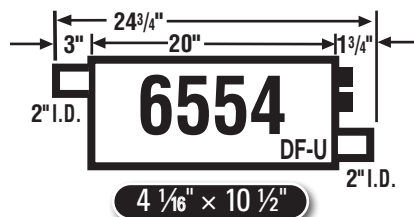

- 83-89 Crown Victoria, Grand Marquis, Sgl. Exh., Dual Exh. (Right)
- 81-89 Town Car, Sgl. Exh., Dual Exh. (Right)
- 80-83 Continental, Mark VI
- 79-82 LTD, Marquis

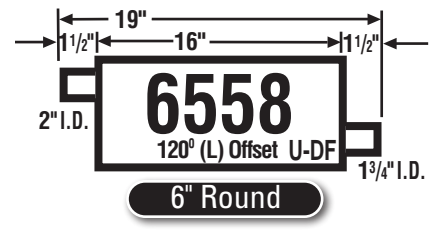

- 84-94 Tempo, Topaz

NOTE: Black area denotes welded head bracket.

DF-U - Denotes muffler used primarily as Direct Fit, but is also Universal.

U-DF - Denotes muffler used primarily as Universal, but is also Direct Fit.

DF - Direct Fit Muffler

U - Universal Muffler

HS - Denotes Heat Shield is on muffler.

MSL MUFFLER BY APPLICATION

FORD / LINCOLN / MERCURY

MSL MUFFLER BY APPLICATION

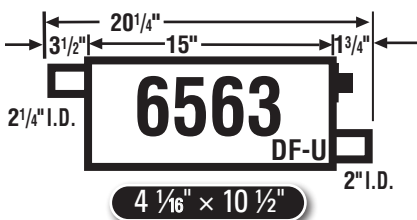

- 83-89 Mustang
- 83-86 Capri

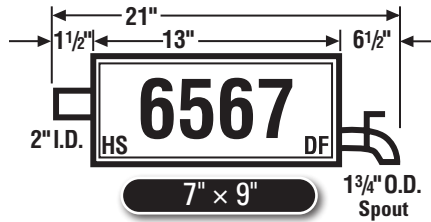

- 85-90 Escort
- 86-88 EXP
- 85-87 Lynx

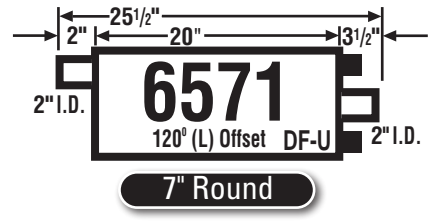

- 85-92 Ranger

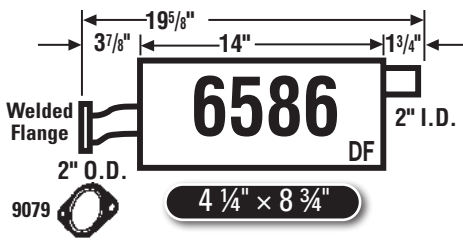

- 86-89 Bronco II

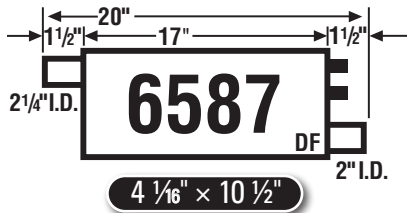

- 87-88 Thunderbird, Cougar



- 87-97 F250/350
- 87-96 F150
- 87-96 Bronco

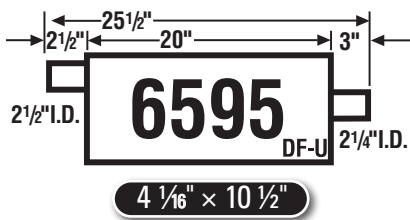

- 75-76 Galaxie, LTD, Marquis

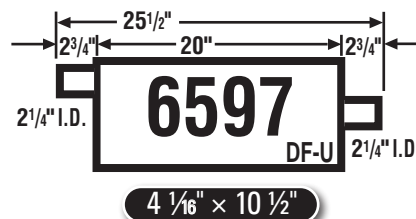

- 91-92 Explorer
- 94-96 Park Avenue, Delta 98, Ninety-Eight
- 1973 LeSabre, Centurion, Electra, Sgl./Dual Exh.
- 73-74 Delta 88, 98
- 73-74 Bonneville, Catalina, Grandville, Sgl. Exh. (Front)
- 73-77 Tornado, All Models, Dual Exh. (Front)
- 1974 LeSabre, Centurion, Electra, Sgl. Exh.
- 74-76 Bel Air, Caprice, Impala, Dual Exh. (Front)
- 1995 Cadillac DeVille

NOTE: Black area denotes welded head bracket.

DF-U - Denotes muffler used primarily as Direct Fit, but is also Universal.

U-DF - Denotes muffler used primarily as Universal, but is also Direct Fit.

DF - Direct Fit Muffler

U - Universal Muffler

HS - Denotes Heat Shield is on muffler.

DIRECT FITS

MAXIMUM **TMSL**

FORD / LINCOLN / MERCURY

MSL MUFFLER BY APPLICATION

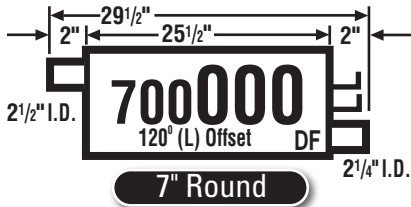

87-96 Econoline, E150/250/350



80-86 F Series
80-84 Bronco



86-89 Aerostar

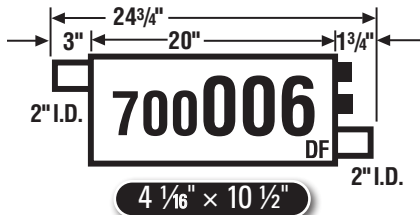

83-89 Grand Marquis, Dual Exh. (Left)
80-89 Crown Victoria, Dual Exh. (Left)
82-89 Town Car, Dual Exh. (Left)
80-82 LTD, Dual Exh. (Left)

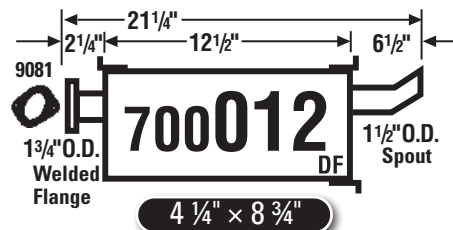

88-93 Festiva

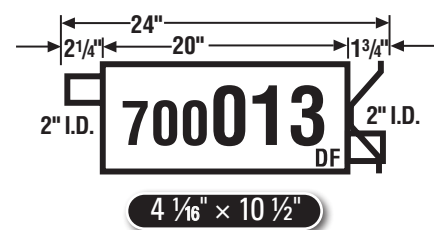

90-91 Crown Victoria, Grand Marquis, Sedan, Sta. Wag., Sgl. Exh., Dual Exh. (Right)

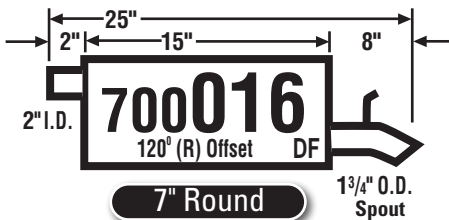

84-94 Tempo, Topaz

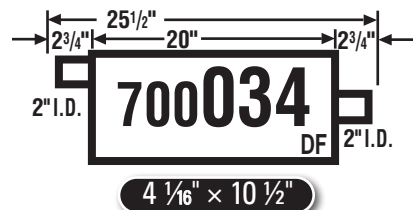

93-03 Ranger

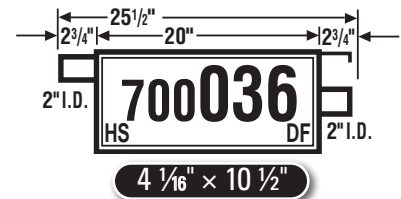

93-94 Explorer 4-Dr.

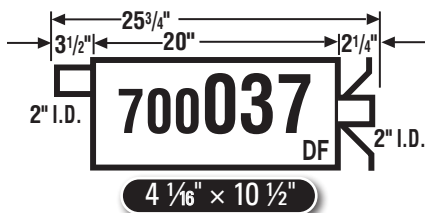

92-97 Crown Victoria, Town Car, Grand Marquis, Sgl. Exh., Dual Exh. (Right)

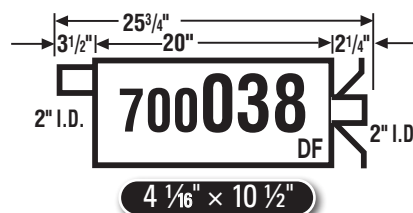

92-97 Crown Victoria, Town Car, Grand Marquis, Dual Exh., (Left)

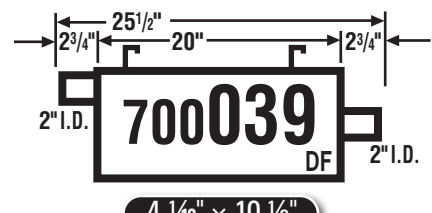

95-03 Ranger

NOTE: Black area denotes welded head bracket.

DF-U - Denotes muffler used primarily as Direct Fit, but is also Universal.

U-DF - Denotes muffler used primarily as Universal, but is also Direct Fit.

DF - Direct Fit Muffler

U - Universal Muffler

HS - Denotes Heat Shield is on muffler.

FORD / LINCOLN / MERCURY

MSL MUFFLER BY APPLICATION

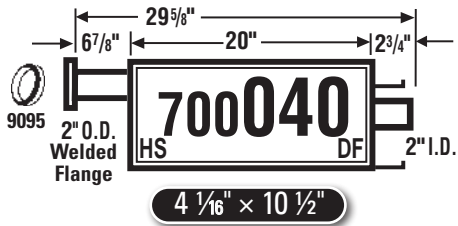

4 1/16" x 10 1/2"

95-00 Explorer 2-Dr.

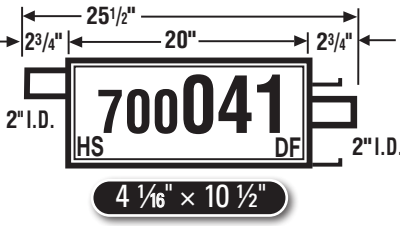

4 1/16" x 10 1/2"

95-00 Explorer 4-Dr.

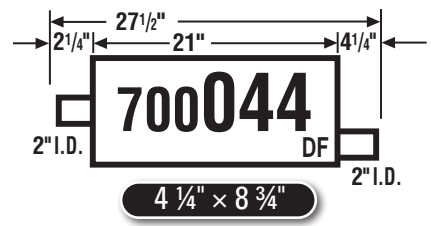

4 1/4" x 8 3/4"

90-97 Aerostar

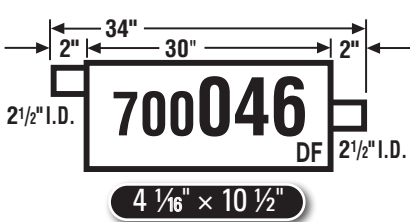

4 1/16" x 10 1/2"

85-97 F250/350/450, Commercial Stripped Chassis, Motor Home



7" Round

83-86 Ranger

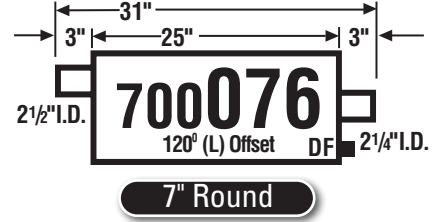

7" Round

84-86 E150/250/350, Econoline

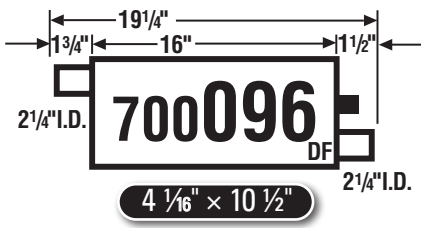

4 1/16" x 10 1/2"

86-93 Mustang, GT, LX, Dual Exh. (Left)
1986 Capri, Dual Exh. (Left)

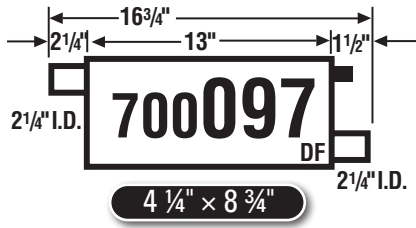

4 1/4" x 8 3/4"

86-93 Mustang, GT, LX, Dual Exh. (Right)
1986 Capri, Dual Exh. (Right)

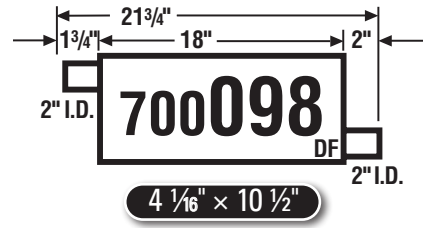

4 1/16" x 10 1/2"

86-95 Taurus, Taurus SHO (86-95), Police Car (91-92), Sgl. Exh., Dual Exh. (Both Sides)
88-94 Continental, Sgl. Exh., Dual Exh. (Both Sides)
86-95 Sable Sedan, Sta. Wag.

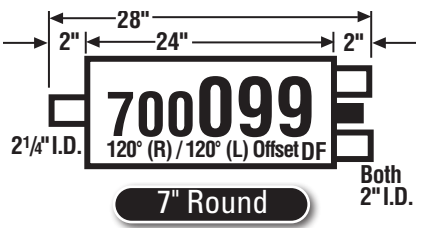

7" Round

87-96 F150/250
84-91 Bronco

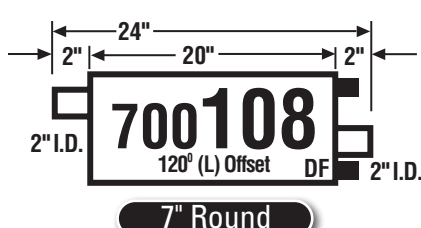

7" Round

87-92 Ranger

NOTE: Black area denotes welded head bracket.

DF-U - Denotes muffler used primarily as Direct Fit, but is also Universal.
U-DF - Denotes muffler used primarily as Universal, but is also Direct Fit.

DF - Direct Fit Muffler
U - Universal Muffler
HS - Denotes Heat Shield is on muffler.

DIRECT FITS

MAXIMUM **MSL**

FORD / LINCOLN / MERCURY

MSL MUFFLER BY APPLICATION

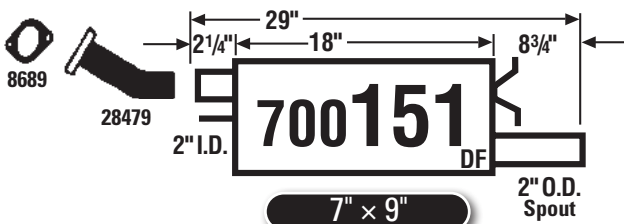

93-97 Probe

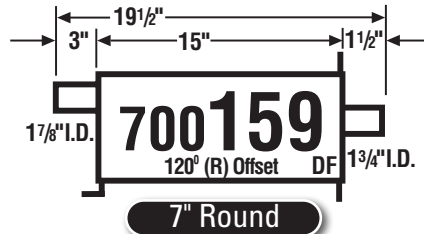

91-03 Escort, Sedan, Sta. Wag.
91-00 Tracer, Sedan, Sta. Wag.

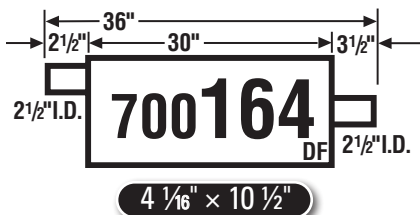

81-94 E250/350
1997 F450, 7.3L

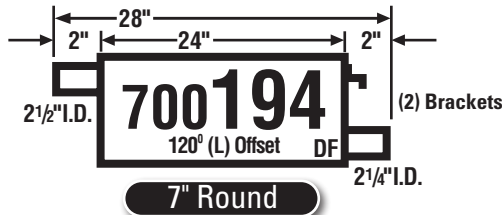

92-96 Econoline E150/250

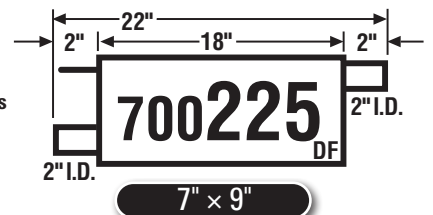

94-97 Villager

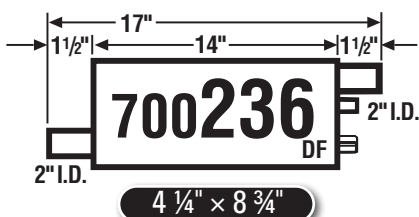

86-87 Continental, Dual Exh. (Right)
86-92 Mark VII, Dual Exh. (Right)

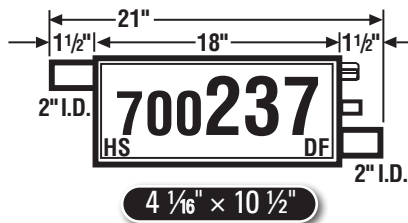

86-87 Continental, Dual Exh. (Left)
86-92 Mark VII, Dual Exh. (Left)

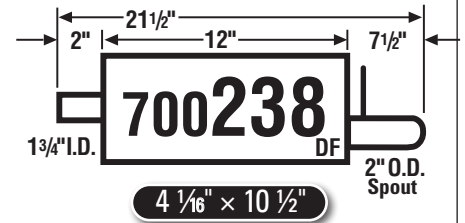

95-00 Contour, Mystique (Rear)

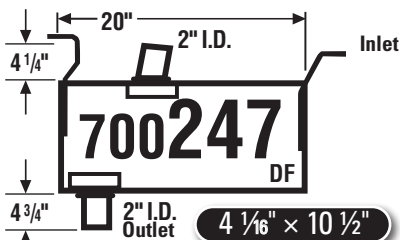

95-03 Windstar
04-07 Freestar, Monterey

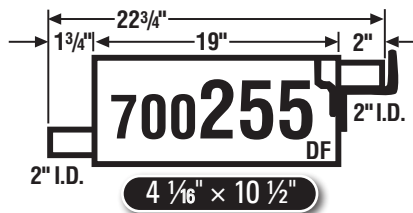

96-99 Taurus, Sable, Dual Exh. (Right)

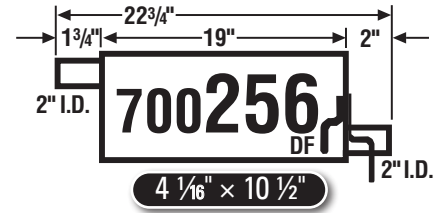

96-99 Taurus, Sable, Sgl. Exh.,
Dual Exh. (Left)

NOTE: Black area denotes welded head bracket.

DF-U - Denotes muffler used primarily as Direct Fit, but is also Universal.

U-DF - Denotes muffler used primarily as Universal, but is also Direct Fit.

DF - Direct Fit Muffler

U - Universal Muffler

HS - Denotes Heat Shield is on muffler.

FORD / LINCOLN / MERCURY

MSL MUFFLER BY APPLICATION

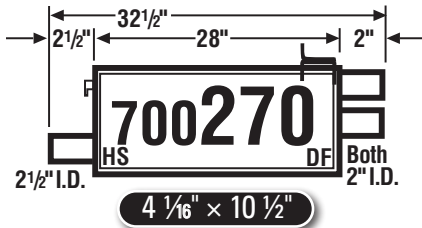

88-97 F250, F350 Series

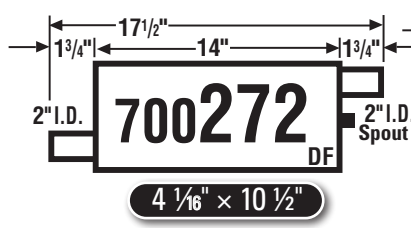

90-93 Mustang

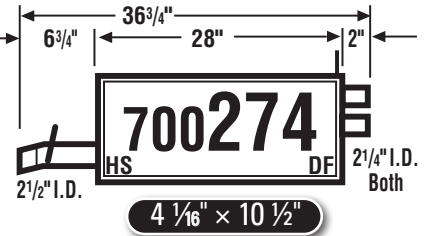

94-96 E250, E350 Series; Econoline, exc. Cutway Van
88-93 E250, E350 Series; Econoline, exc. Cutway Van; exc. 1993 7.5L w/ Round Muffler

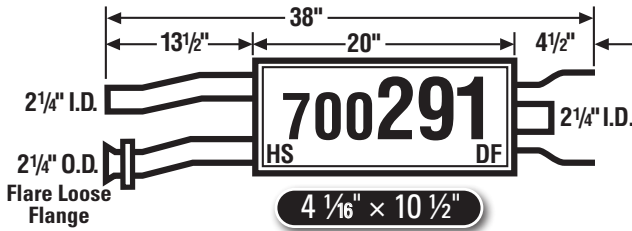

97-00 Explorer 4 dr.
98-00 Moutaineer

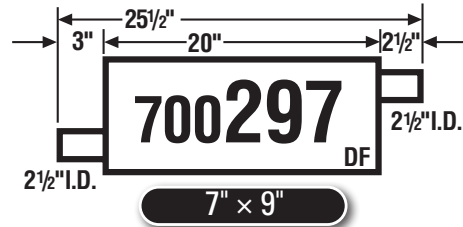

97-04 F100, F150 Series
97-99 F250 Series

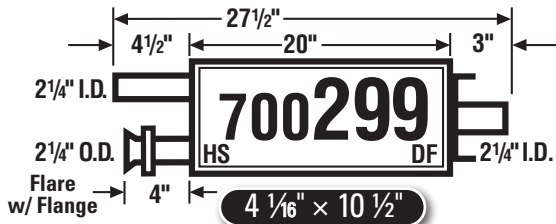

97-00 Explorer 2 dr.



97-03 E Series, Econoline

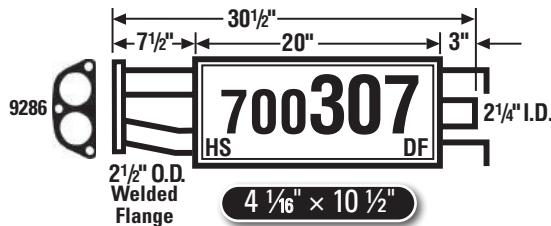

96-98 Explorer 5.0L, 4 dr.
97-98 Moutaineer

NOTE: Black area denotes welded head bracket.

DF-U - Denotes muffler used primarily as Direct Fit, but is also Universal.

U-DF - Denotes muffler used primarily as Universal, but is also Direct Fit.

DF - Direct Fit Muffler

U - Universal Muffler

HS - Denotes Heat Shield is on muffler.

DIRECT FITS

MAXIMUM **TMSL**

FORD / LINCOLN / MERCURY

MSL MUFFLER BY APPLICATION

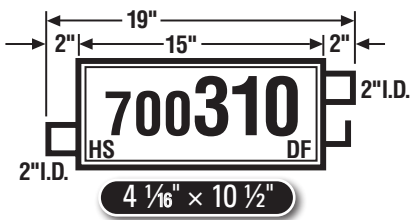

94-98 Mustang, 6 cyl.

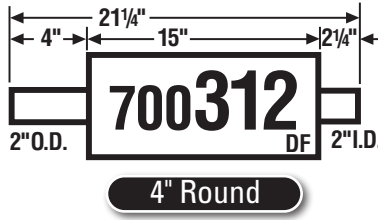

95-98 Windstar (Rear)

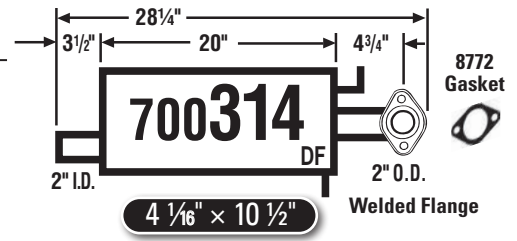

98-02 Full Size Models, Sgl. Exh, Dual Exh. (Right)

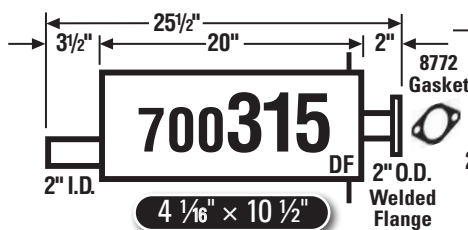

98-02 Full Size Models, Dual Exh. (Left)

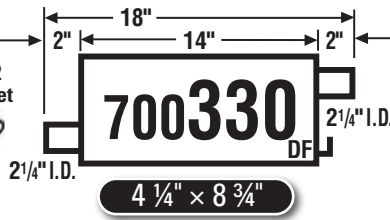

94-04 Mustang GT, Dual Exh (Left) SOHC
03-04 Mustang Mach I, Dual Exh (Left) DOHC
99-04 Mustang, 6 cyl. Single Exh

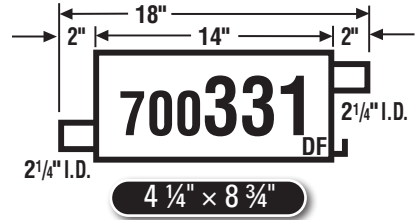

94-04 Mustang GT, Dual Exh (Right) SOHC
03-04 Mustang Mach I, Dual Exh (Right) DOHC

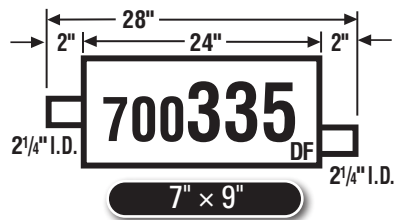

02-05 Explorer, Mountaineer

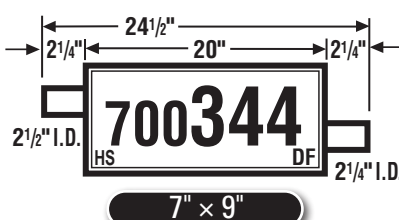

97-98 Expedition
1998 Navigator

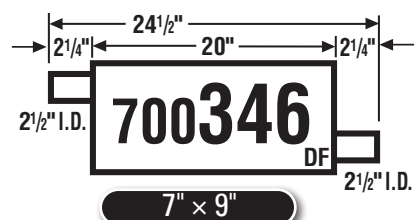

99-02 Expedition, Navigator



98-02 Villager (Rear)

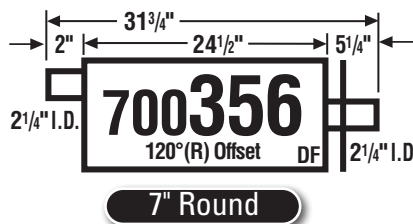

1996 F150 (inc. Super Cab), 5.0L

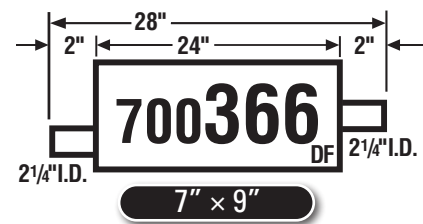

06-10 Explorer
01-10 Explorer Sport Trac
06-10 Mountaineer

NOTE: Black area denotes welded head bracket.

DF-U - Denotes muffler used primarily as Direct Fit, but is also Universal.

U-DF - Denotes muffler used primarily as Universal, but is also Direct Fit.

DF - Direct Fit Muffler

U - Universal Muffler

HS - Denotes Heat Shield is on muffler.

FORD / LINCOLN / MERCURY

MSL MUFFLER BY APPLICATION

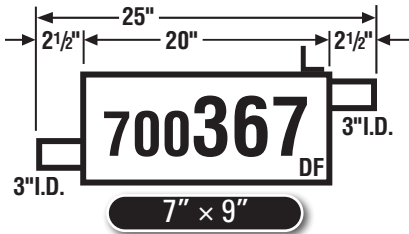

99-04 F250, F350, Super Duty

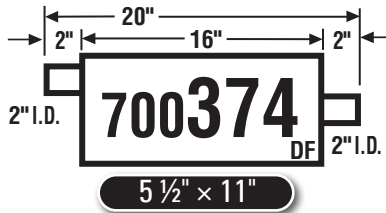

95-02 Continental, Dual Exh (Both)

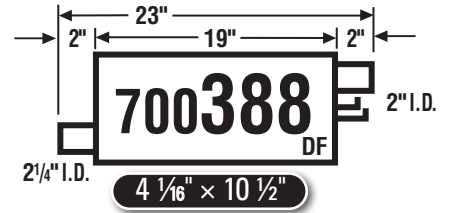

00-07 Taurus, Sable

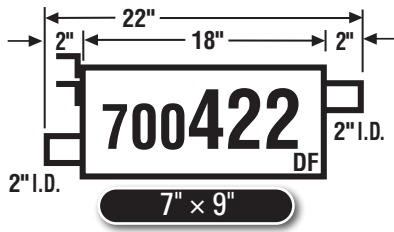

04-11 Ranger (exc. CA)

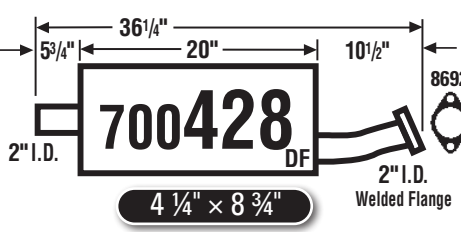

01-04 Escape

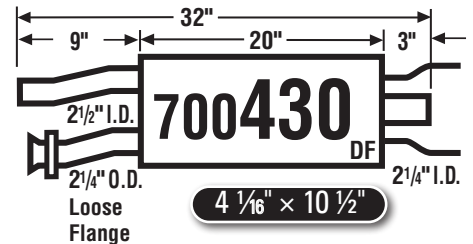

4/98-01 Explorer, Mountaineer, 4-Dr., 8 cyl.

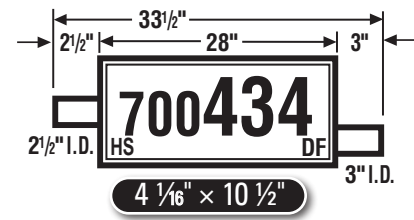

88-96 E350, 158" & 176" W.B.

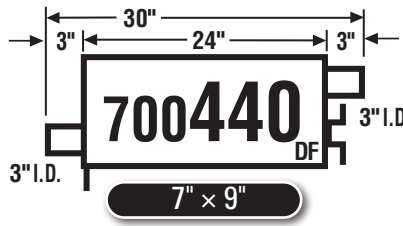

97-03 E150, E250, E350, 5.4L

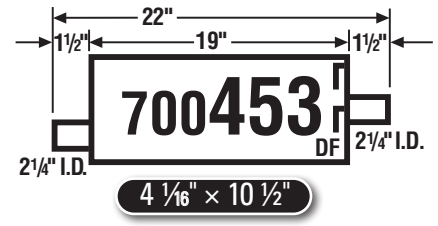

00-01 Explorer, 4.0L., 4-Dr. (From 12/99)

00-03 Explorer Sport, 4.0L., 2-Dr. (From 12/99)

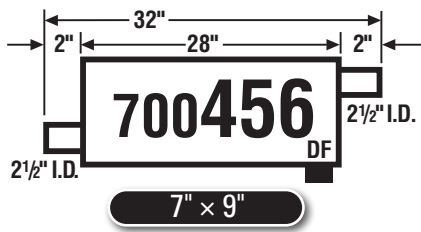

04-08 F150, 4.2L (exc. Heritage Series, Old Body Style)

04-08 F150, 4.6L & 5.4L (exc. Heritage Series, Old Body Style)

06-08 Mark LT, 5.4L

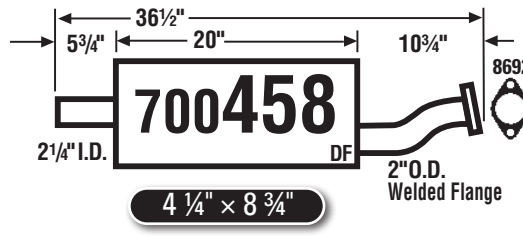

05-08 Escape, 2.3L

05-08 Escape, 3.0L

05-08 Mariner, 2.3L

05-08 Mariner, 3.0L

05-08 Tribute, 2.3L

05-08 Tribute, 3.0L

NOTE: Black area denotes welded head bracket.

DF-U - Denotes muffler used primarily as Direct Fit, but is also Universal.

U-DF - Denotes muffler used primarily as Universal, but is also Direct Fit.

DF - Direct Fit Muffler

U - Universal Muffler

HS - Denotes Heat Shield is on muffler.

DIRECT FITS

MAXIMUM **TMSL**

FORD / LINCOLN / MERCURY

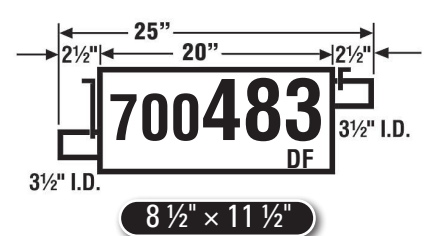
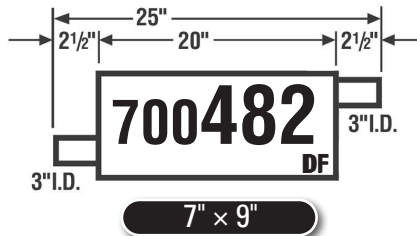
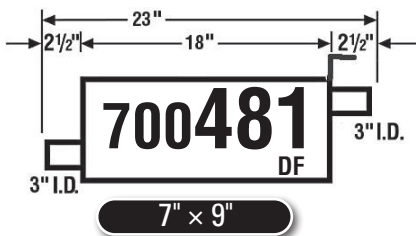

05-07 Ford, F-250 Super Duty, V10-6.8L, V8-5.4L

2005 Ford, F-350 Super Duty, V10-6.8L

2007 Ford, F-350 Super Duty, V10-6.8L

05-07 Ford, F-350 Super Duty, V8-5.4L

04-14 Ford, E-150, E-250, E-350 Super Duty, V8-5.4L

2004 Ford, E150 Club Wagon, V8-5.4L

04-05 Ford, E-250 Super Duty, E-350 Club Wagon, V8-5.4L

00-05 Ford, Excursion, V8-5.4L, V10-6.8L

99-03 Ford, F-250 Super Duty, F-350 Super Duty, V8-7.3L

GENERAL MOTORS

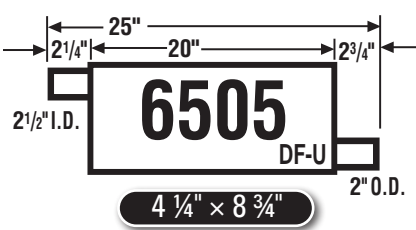

69-84 C, K, P Series, 1/2 - 1 Ton
75-80 Blazer, Jimmy

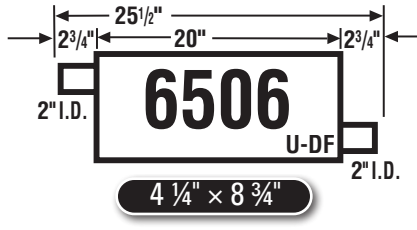

71-72 Bel Air, Biscayne, Impala
70-72 Chevelle, Tempest, All Models
70-72 Sprint

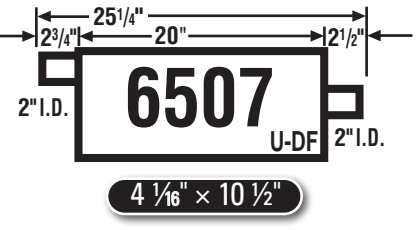

73-74 Chevelle, LeMans, Grand Prix, GTO
73-74 Sprint
1973 All Models

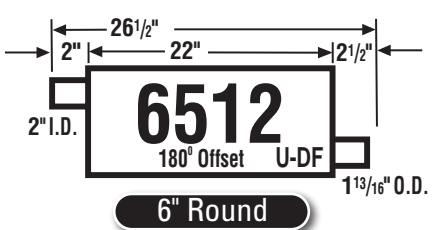

67-71 10, 20, 30 Series (exc. Carryall), 1/2 - 2 Ton Series
67-70 C Series
67-68 G Series
67-71 P Series

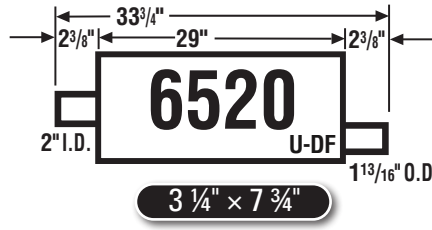

58-64 Chev. 6-8 cyl. All Models, exc. Hi. Performance
58-59 Series 5,000-10,000
54-57 Chev. 6-8 cyl. (exc. Conv.)

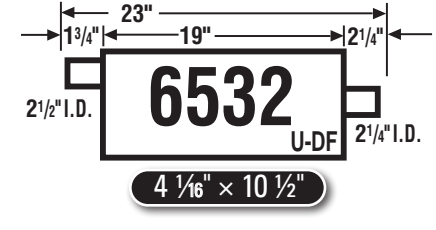

71-74 Cadillac 8 cyl. All Models (Front)

NOTE: Black area denotes welded head bracket.

DF-U - Denotes muffler used primarily as Direct Fit, but is also Universal.

U-DF - Denotes muffler used primarily as Universal, but is also Direct Fit.

DF - Direct Fit Muffler

U - Universal Muffler

HS - Denotes Heat Shield is on muffler.

GENERAL MOTORS

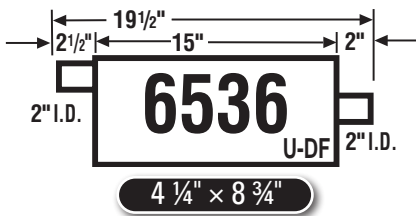

75-80 Monza, Starfire, Sunbird

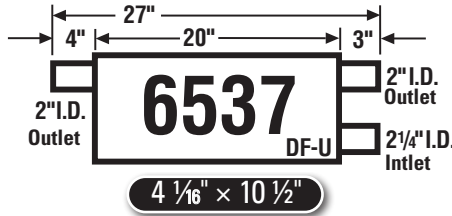

75-81 Camaro, Firebird
75-79 Apollo, Skylark, Chevy II, Nova, Omega, Ventura II, Phoenix

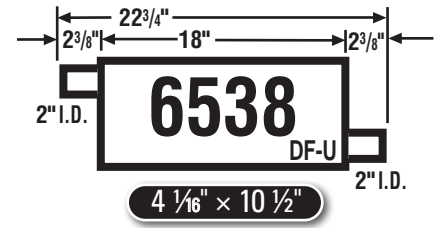

86-87 Century, Celebrity, Cutlass, 6000
82-86 Firebird
82-86 Camaro
80-85 GM Full Size

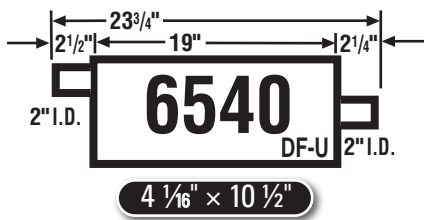

78-87 Regal, Cutlass, Century, Bonneville, Grand Prix
78-84 Malibu, Monte Carlo, El Camino, Caballero
78-81 Century, LeMans, Grand AM

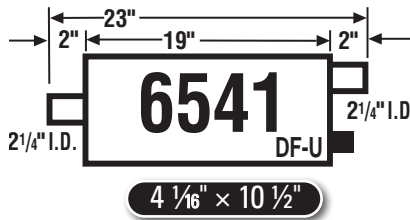

80-85 Eldorado, Seville
79-85 Riviera, Toronado



84-96 Century, Cutlass Ciera
85-91 6000
85-90 Celebrity
77-90 GM Full Size
1985 Cad. Full Size
79-82 Cad. Full Size

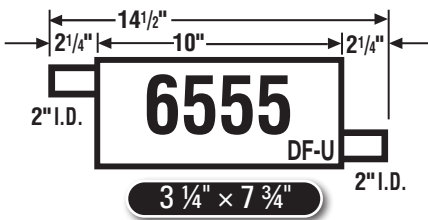

77-81 Camaro, Z28
78-81 Firebird, Trans AM

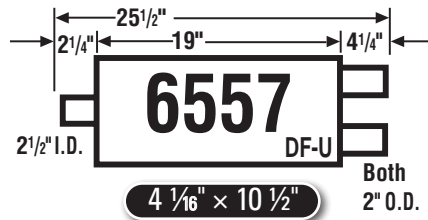

80-87 Blazer, Jimmy
80-87 C, K, R, V, Suburban Series, 1/2 - 3/4 Ton

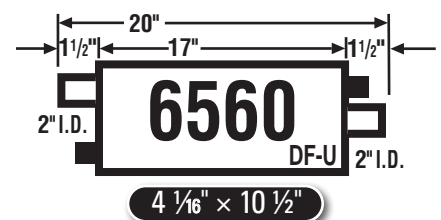

84-94 Cavalier, Sunbird
86-91 Skylark
85-91 Calais, Grand AM
84-89 Skyhawk, Cimarron
84-88 Firenzeza
85-87 Somerset, Somerset Regal (Rear Exit Only With Spout Welded To Muffler - see 700060)

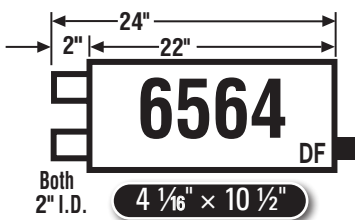

84-86 Century, Celebrity, Cutlass Ciera, 6000

NOTE: Black area denotes welded head bracket.

DF-U - Denotes muffler used primarily as Direct Fit, but is also Universal.

U-DF - Denotes muffler used primarily as Universal, but is also Direct Fit.

DF - Direct Fit Muffler

U - Universal Muffler

HS - Denotes Heat Shield is on muffler.

GENERAL MOTORS

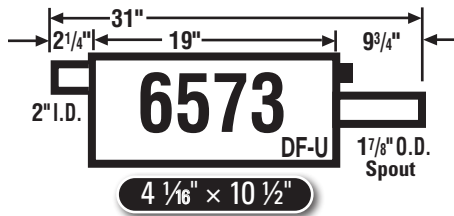

82-87 Century, Celebrity, Cutlass Ciera, 6000

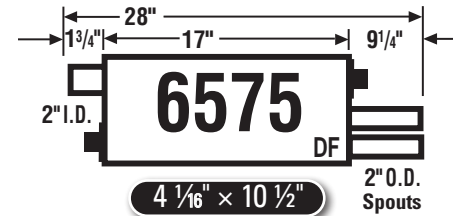

84-91 Sunbird
84-89 Cavalier, Skyhawk
86-88 Skylark
85-88 Calais
84-88 Firenza
85-87 Somerset, Somerset Regal, Grand AM

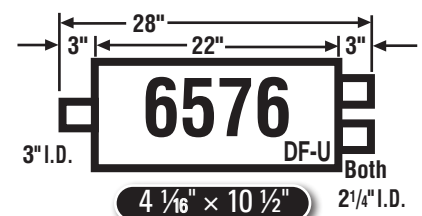

91-95 C2500, K2500, C3500, K3500
91-93 C1500

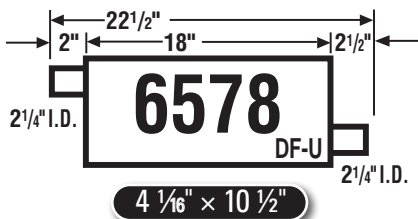

86-91 GM Full Size, Riviera, Toronado
86-87 Eldorado, Seville

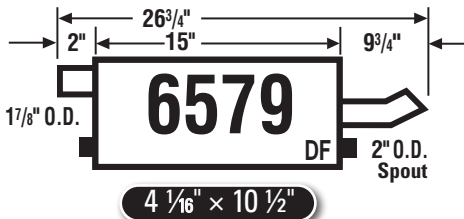

90-93 Lumina
88-93 Regal, Cutlass Supreme, Grand Prix

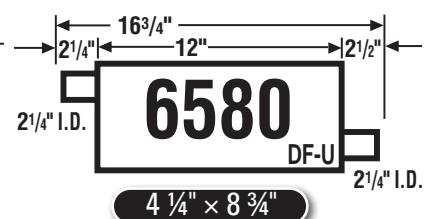

75-79 Seville

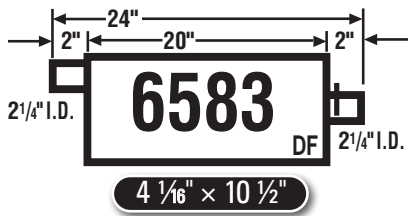

85-91 Astro, Safari Van

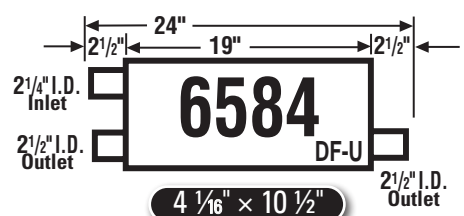

88-92 Camaro, Firebird

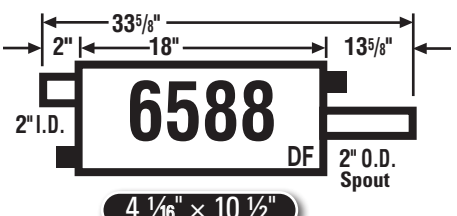

87-92 Beretta, Corsica
87-91 Pontiac Tempest (Canada)

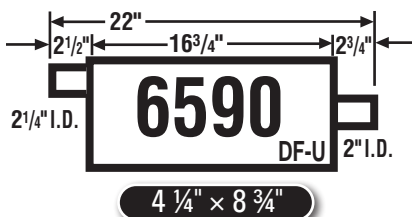

82-91 S10/S15, T10/T15
83-89 Blazer, Jimmy

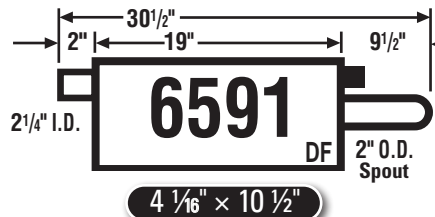

84-92 Century, Cutlass Ciera
86-91 6000
86-89 Celebrity

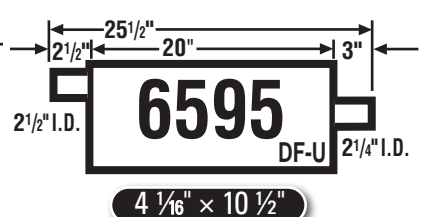

1982 G Series Van
1978 Toronado
75-77 GM Full Size, Century, Cutlass, LeMans, Grand Prix

NOTE: Black area denotes welded head bracket.

DF-U - Denotes muffler used primarily as Direct Fit, but is also Universal.

U-DF - Denotes muffler used primarily as Universal, but is also Direct Fit.

DF - Direct Fit Muffler
U - Universal Muffler

HS - Denotes Heat Shield is on muffler.

GENERAL MOTORS

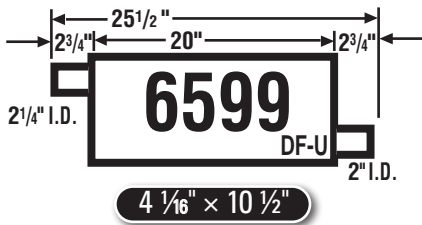

- 71-73** Chev. Full Size, Sgl. Exh. (71-72); All Models w/ Dual Exh., exc. Sta. Wag. (Front)
- 71-72** Delta 88, Catalina, Sgl. Exh., exc. Sta. Wag.
- 68-72** F85 Series, Vista Cruiser
- 65-72** 3300/3400/3435/4000/4400/4600 Series, Catalina, Skylark, LeSabre
- 1969** Sportswagon, Special
- 65-68** 3000 Series
- 66-67** F85 Series, Dual Exh., exc. model 442 (Right)
- 65-66** 6000/8000 Series, Electra, Wildcat, Dual Exh. (both sides, front)
- 1965** Model 442 (Both Sides)
- 1965** Catalina, Sgl. Exh., exc. Sta. Wag., All Models w/Dual Exh. (Both Sides)
- 75-78** G Series Van



- 75-82** Luv

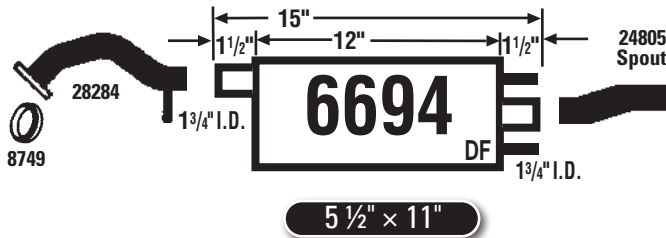

- 90-92** Geo Prizm (Welded Assembly Available)

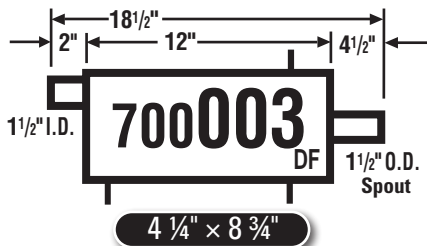

- 89-94** Geo Metro
- 89-94** Chevrolet Sprint (Canada)

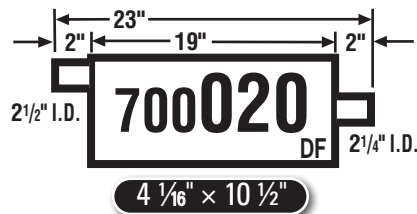

- 88-04** T10/T15
- 88-95** S10/S15
- 88-91** Blazer, Jimmy
- 1991** Bravada
- 88-04** Sonoma

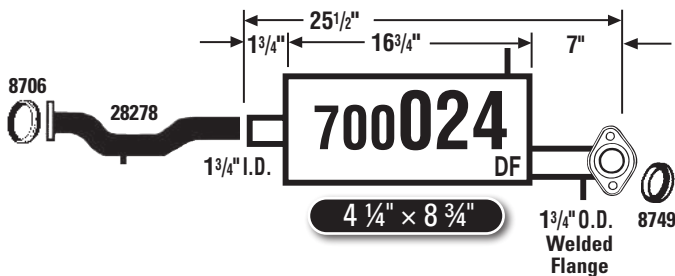

- 89-95** Geo Tracker

NOTE: Black area denotes welded head bracket.

DF-U - Denotes muffler used primarily as Direct Fit, but is also Universal.

U-DF - Denotes muffler used primarily as Universal, but is also Direct Fit.

DF - Direct Fit Muffler

U - Universal Muffler

HS - Denotes Heat Shield is on muffler.

GENERAL MOTORS

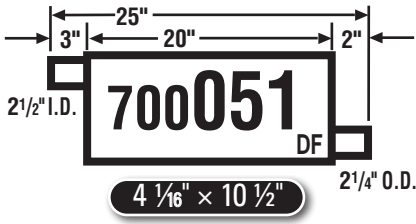

- 88-93** C1500/2500, K1500/2500
- 83-93** G20/2500, G30/3500
- 82-90** P30/3500
- 85-87** C10/1500, C20/2500, K10/1500, R10/1500, R20/2500, V10/1500
- 81-85** Suburban
- 75-85** Series C, K
- 78-84** C Series, K30/3500
- 80-82** Blazer, Jimmy
- 75-82** C10/1500, C30/3500, K Series
- 1979** Suburban

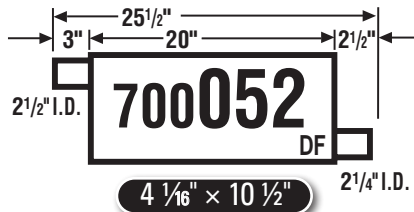

- 75-94** G Series Van
- 71-73** Chev. Full Size Models



- 77-90** LeSabre, Estate Wagon
- 86-90** Caprice Sta. Wagon
- 81-85** Caprice, Impala, Sta. Wag.
- 77-90** Delta 88 (77-79), Custom Cruiser (80-90)
- 87-89** Safari Sta. Wag.
- 83-86** Parisienne Sta. Wag.
- 77-81** Catalina, Bonneville, Sta. Wag., Safari Sta. Wag. (1981)

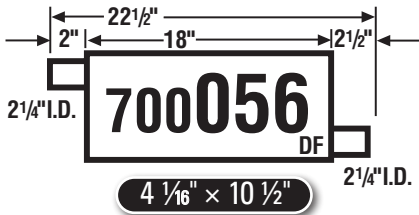

- 83-90** Estate Wagon
- 80-85** Buick Full Size
- 81-84** Electra, Park Avenue (exc. Estate Wagon)
- 77-81** LeSabre
- 77-79** Electra, Riviera
- 81-90** Brougham (86-90), Fleetwood Brougham
- 81-85** Fleetwood, DeVille
- 77-82** Cad. Full Size
- 81-90** Caprice, Impala (81-85)
- 86-90** Custom Cruiser
- 77-85** Delta 88, 98
- 83-89** Parisienne (83-86), Safari Sta. Wag. (87-89)
- 77-81** Catalina, Bonneville

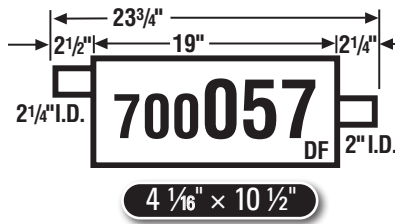

- 78-87** Century, Regal
- 78-88** Chevelle, Monte Carlo
- 78-87** El Camino, Malibu
- 79-87** Caballero
- 78-88** Cutlass, Cutlass Cruiser Sta. Wag. (80-81)
- 79-87** Bonneville (82-86), Grand Prix
- 79-81** LeMans, Grand AM

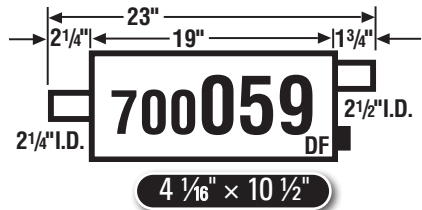

- 79-85** Eldorado, Seville (80-85)

NOTE: Black area denotes welded head bracket.

DF-U - Denotes muffler used primarily as Direct Fit, but is also Universal.

U-DF - Denotes muffler used primarily as Universal, but is also Direct Fit.

DF - Direct Fit Muffler

U - Universal Muffler

HS - Denotes Heat Shield is on muffler.

GENERAL MOTORS

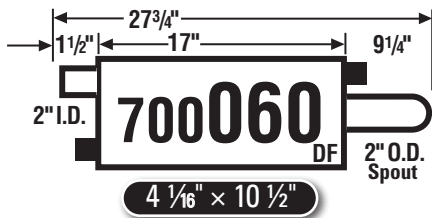

- 84-94 Cavalier, Sunbird
- 86-91 Skylark
- 85-91 Calais, Grand AM
- 84-89 Skyhawk
- 84-88 Cimarron, Firenza
- 85-87 Somerset, Somerset Regal (Rear Exit Only)

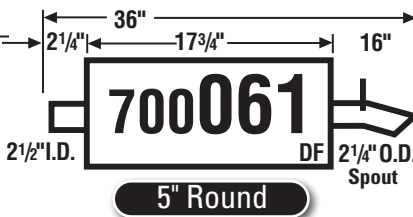

- 80-81 Riviera
- 79-85 Eldorado, Seville
- 79-81 Toronado

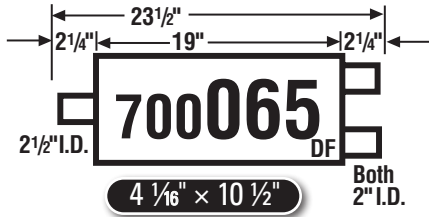

- 80-94 G Series
- 82-88 P30/P3500

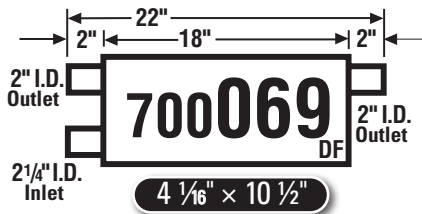

- 85-90 Camaro, Firebird
- 82-87 Camaro, Berlinetta (exc. Z28)
- 82-87 Firebird (exc. Trans AM)

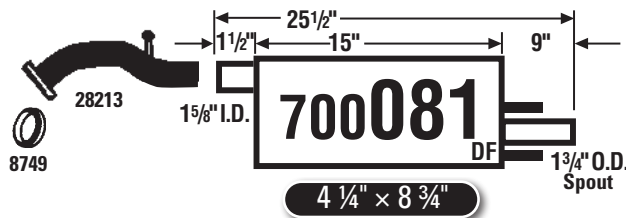

- 85-88 Nova

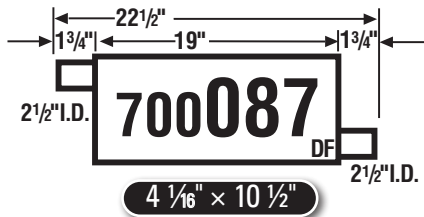

- 91-93 Roadmaster (Front)
- 90-93 Brougham, Fleetwood Brougham (Front)
- 85-93 Caprice, Impala (Front)
- 91-92 Custom Cruiser (Front)
- 85-86 Parisienne (Front)

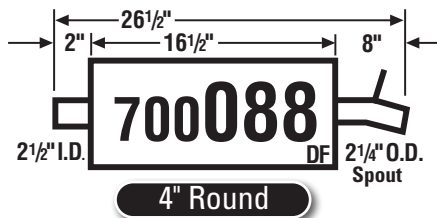

- 90-92 Brougham (Rear)
- 85-89 Caprice, Impala, Sedan (Rear)
- 85-86 Parisienne Sedan (Rear)

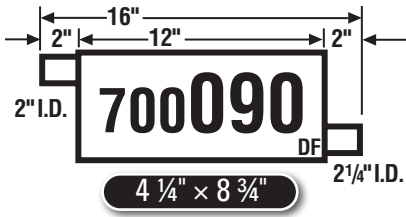

- 83-88 Monte Carlo SS Dual Exh. (Both Sides)

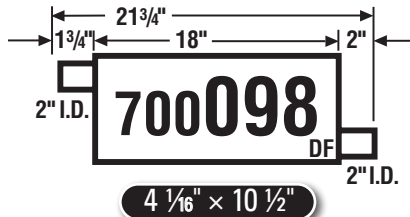

- 03-08 Pontiac Vibe

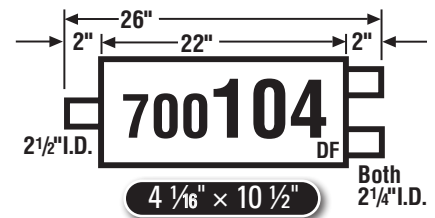

- 90-93 C1500, C2500, K1500, K2500
- 1990 C2500/K2500
- 88-90 Series C, K

NOTE: Black area denotes welded head bracket.

DF-U - Denotes muffler used primarily as Direct Fit, but is also Universal.

U-DF - Denotes muffler used primarily as Universal, but is also Direct Fit.

DF - Direct Fit Muffler

U - Universal Muffler

HS - Denotes Heat Shield is on muffler.

GENERAL MOTORS

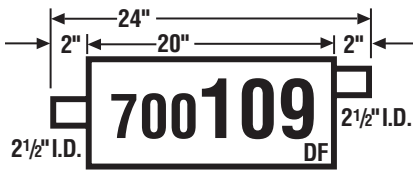

4 1/16" x 10 1/2"

- 87-89 Blazer, Jimmy
- 87-88 V10/V1500, Suburban
- 1987 R10/R1500, R20/R2500

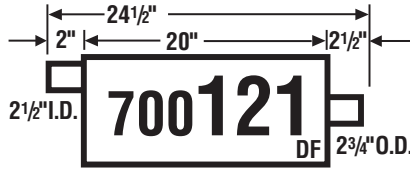

4 1/16" x 10 1/2"

- 90-91 Blazer, Jimmy
- 88-91 V10/V1500, V20/2500, Suburban
- 88-90 R10/R1500, R20/R2500

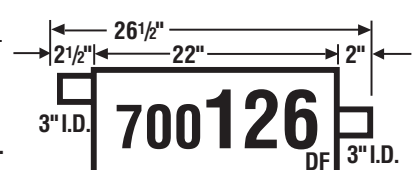

4 1/16" x 10 1/2"

- 1991 G Series
- 88-95 C/K Series



4 1/16" x 10 1/2"

- 87-96 P30/P3500
- 87-89 G30/G3500, R20/R2500, R30/R3500, V20/V2500, V30/V3500

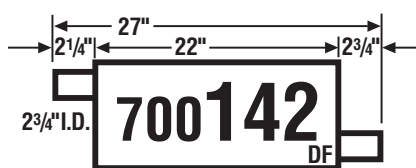

7" x 9"

- 94-95 C1500/2500, K1500/2500

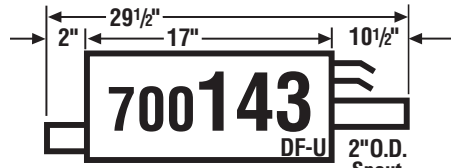

7" x 9"

- 94-96 Century, Cutlass Ciera, exc. Sta. Wag.

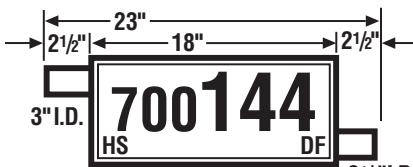

7" x 9"

- 92-95 Astro/Safari Van

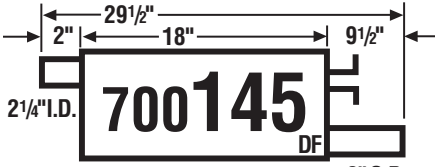

4 1/16" x 10 1/2"

- 1993 Century, Cutlass Ciera, Sedan

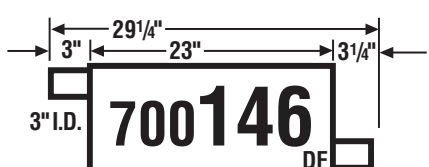

7" x 9"

- 92-96 G Series Van

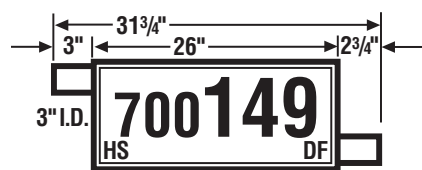

7" x 9"

- 92-93 C1500/2500, K1500/2500, Suburban

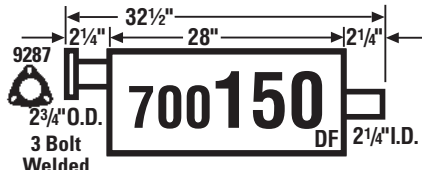

5 1/2" x 11"

- 95-99 S10/T10, Blazer/Jimmy, 4-Dr.
- 96-99 Bravada



7" x 9"

- 94-95 C1500/2500, K1500/2500, Suburban

NOTE: Black area denotes welded head bracket.

DF-U - Denotes muffler used primarily as Direct Fit, but is also Universal.

U-DF - Denotes muffler used primarily as Universal, but is also Direct Fit.

DF - Direct Fit Muffler

U - Universal Muffler

HS - Denotes Heat Shield is on muffler.

GENERAL MOTORS



7" x 9"

94-95 C1500/2500, K1500/2500

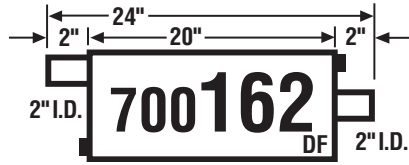

4 1/16" x 10 1/2"

92-94 Skylark, Achieva, Grand AM
93-94 Beretta, Corsica, exc. Beretta GT/GTZ, Z26



4 1/16" x 10 1/2"

1992 Astro/Safari Van



4 1/16" x 10 1/2"

94-96 Roadmaster, Fleetwood Brougham (RWD), Caprice (Dual Exh., all Front Right) Caprice (Sgl. Exh., and Dual Exh.)



4 1/16" x 10 1/2"

94-96 Roadmaster, Fleetwood Brougham (RWD), Caprice (Dual Exh., all Front Left)



7" x 9"

94-95 Tahoe/Yukon



7" x 9"

92-93 Blazer/Yukon



4 1/16" x 10 1/2"

92-94 S10/S15 Pickup



5 1/2" x 11"

92-94 Bravada 4 WD
92-94 Blazer/Jimmy 2 WD (S10/S15), 4 WD (T10/T15)



4 1/4" x 8 3/4"

95-97 Geo Metro
98-01 Chev. Metro
95-01 Pontiac Firefly (Canada)

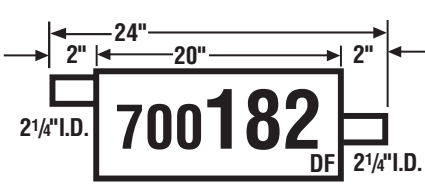

4 1/16" x 10 1/2"

95-03 S10/S15 Pickup



7" x 9"

1995 G Series

NOTE: Black area denotes welded head bracket.

DF-U - Denotes muffler used primarily as Direct Fit, but is also Universal.

U-DF - Denotes muffler used primarily as Universal, but is also Direct Fit.

DF - Direct Fit Muffler

U - Universal Muffler

HS - Denotes Heat Shield is on muffler.

GENERAL MOTORS

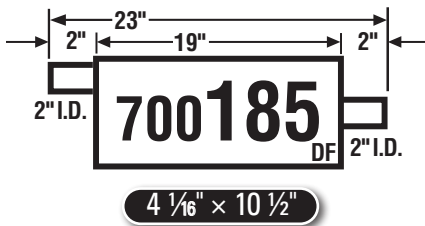

- 95-05 Cavalier, Sunfire
- 95-99 DeVille, Eldorado, Dual Exh. (Both Sides)
- 95-98 Skylark, Achieva, Grand AM
- 95-97 Seville, Dual Exh. (Both Sides)
- 95-96 Beretta/Corsica

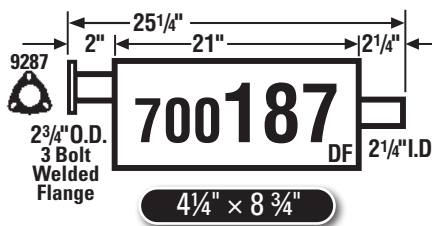

- 95-99 S10/T10, Blazer/Jimmy, 2-Dr.

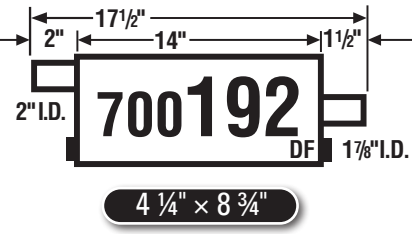

- 90-92 Cutlass Supreme, Grand Prix; (Right)

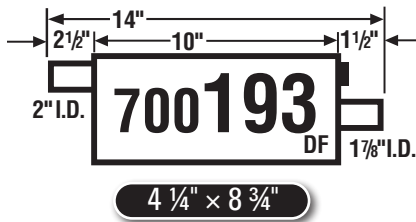

- 90-92 Cutlass Supreme, Grand Prix; (Left)

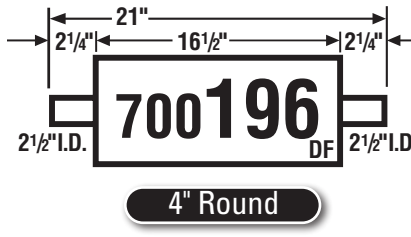

- 91-93 Roadmaster Estate Sta. Wag., Caprice Sta. Wag.
- 91-92 Custom Cruiser
- 85-86 Caprice/Impala Sta. Wag., Parisienne Sta. Wag.

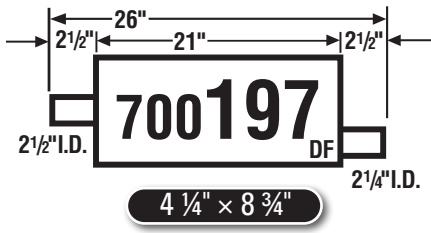

- 92-93 LeSabre, 88, Bonneville SE

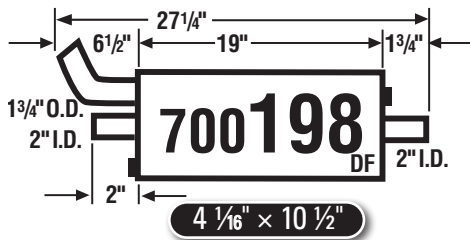

- 92-94 Achieva, Grand AM (Left)

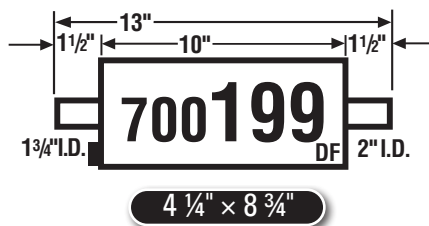

- 92-94 Achieva, Grand AM (Right)

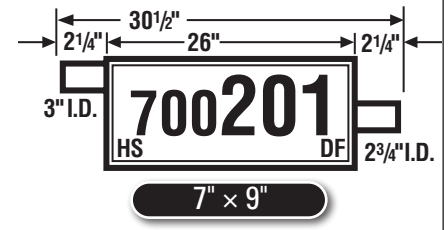

- 94-95 C/K 1500/2500, Suburban; 2 WD/4 WD, with 3" Inlet

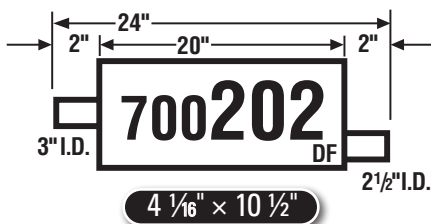

- 87-88 V10/1500, V20/2500, Suburban; 4 WD, with 3" Inlet

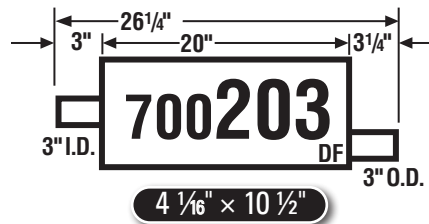

- 87-88 R10/1500, R20/2500, Suburban; 2 WD, with 3" Inlet

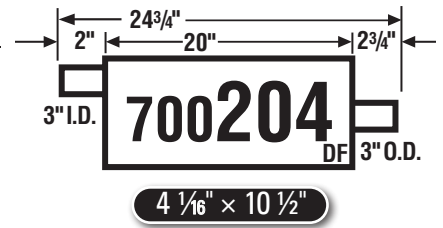

- 87-90 G10, G20, G30/G1500, G2500, G3500, with 3" Inlet

NOTE: Black area denotes welded head bracket.

DF-U - Denotes muffler used primarily as Direct Fit, but is also Universal.

U-DF - Denotes muffler used primarily as Universal, but is also Direct Fit.

DF - Direct Fit Muffler

U - Universal Muffler

HS - Denotes Heat Shield is on muffler.

GENERAL MOTORS

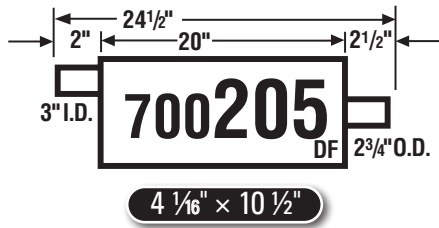

88-91 V10/1500, V20/2500, Suburban; 4 WD, with 3" Inlet
88-90 R10/1500, R20/2500, Suburban; 2 WD, with 3" Inlet

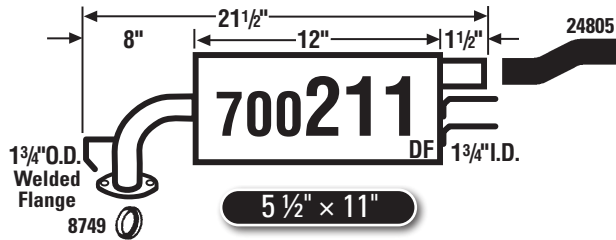

93-97 Geo Prizm, Prizm LSI (Welded Assembly Available)

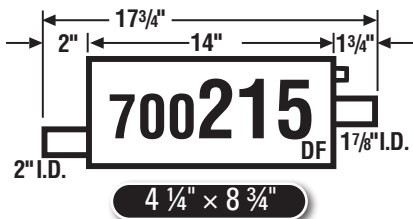

1993 Cutlass Supreme, Dual Exh. (Right)
93-96 Grand Prix, Dual Exh. (Right)

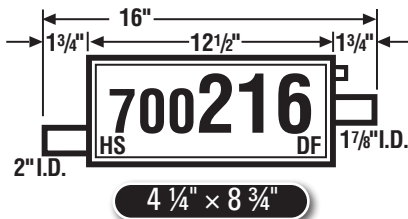

1993 Cutlass Supreme, Dual Exh. (Left)
93-96 Grand Prix, Dual Exh. (Left)

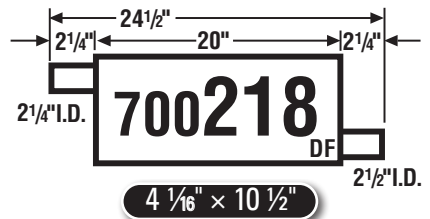

93-02 Camaro, Firebird

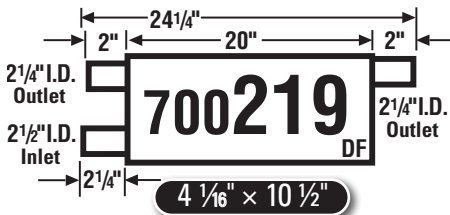

93-02 Camaro, Firebird

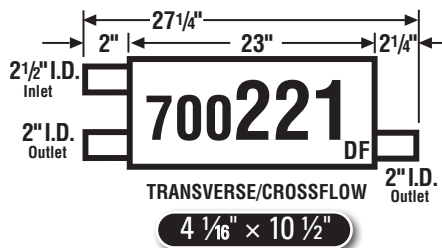

1992 Eldorado, Seville

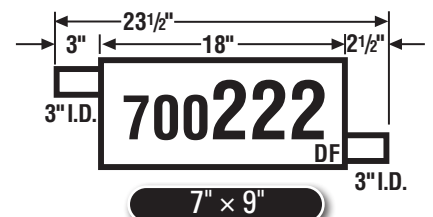

90-95 C3500, K3500

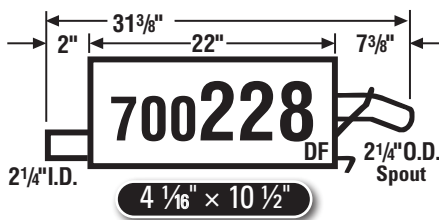

1994 DeVille

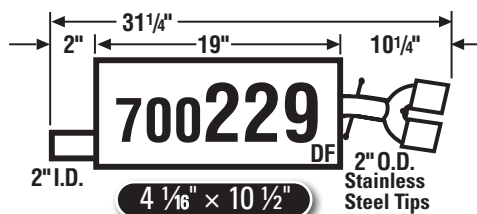

93-94 Eldorado, Seville, Dual Exh. (Right)

NOTE: Black area denotes welded head bracket.

DF-U - Denotes muffler used primarily as Direct Fit, but is also Universal.

U-DF - Denotes muffler used primarily as Universal, but is also Direct Fit.

DF - Direct Fit Muffler

U - Universal Muffler

HS - Denotes Heat Shield is on muffler.

DIRECT FITS

MAXIMUM **TMSL**

GENERAL MOTORS

MSL MUFFLER BY APPLICATION

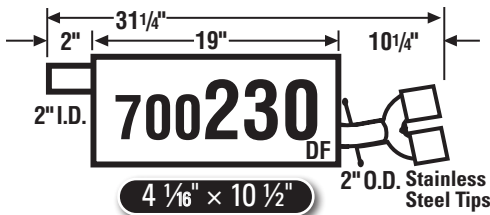

93-94 Eldorado, Seville, Dual Exh. (Left)



94-96 Roadmaster, Caprice, Sedan, Sgl. Exh. (Rear), Dual Exh. (Right Rear)



94-96 Roadmaster, Caprice, Sedan, Dual Exh. (Left Rear)

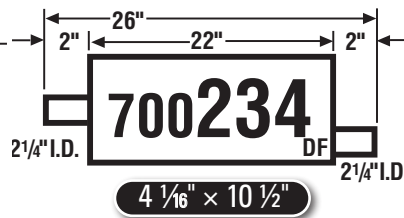

02-07 Rendezvous
01-05 Aztek
94-99 LeSabre, 88, Bonneville

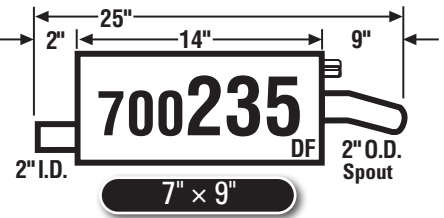

94-96 Regal, Grand Prix
1994 Lumina
94-97 Cutlass Supreme

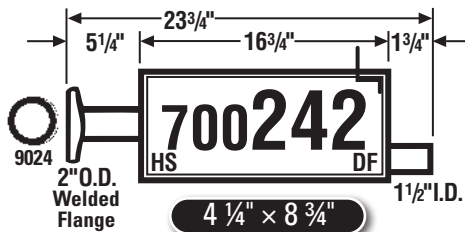

1998 Chev./GMC Tracker, 2-Dr. Models
94-97 Geo Tracker, 2-Dr. & Convertibles

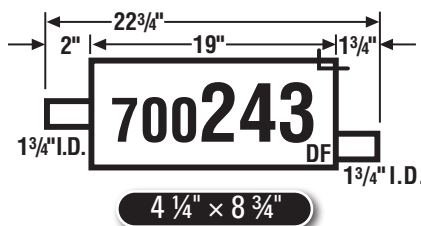

1998 Chev./GMC Tracker, 4-Dr. Models
96-97 Geo Tracker, 4-Dr., Hardtop

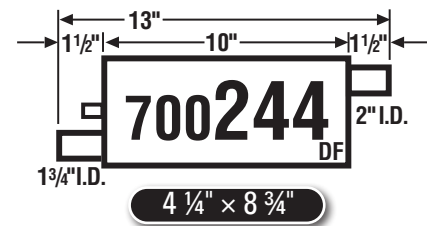

96-98 Grand Am GT, Dual Exh. (Right)
1995 Grand Am, Dual Exh. (Right)

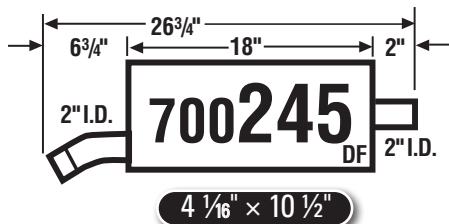

96-98 Grand Am GT, Dual Exh. (Left)
1995 Grand Am, Dual Exh. (Left)

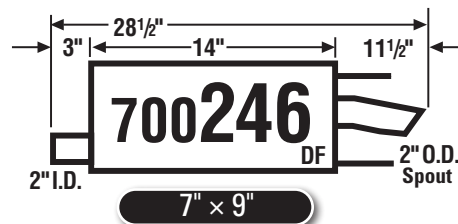

95-01 Lumina
95-99 Monte Carlo

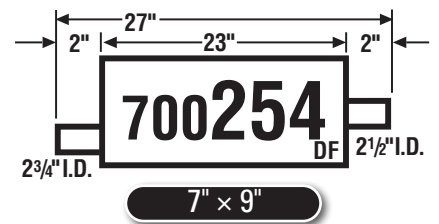

96-05 Astro/Safari Van

NOTE: Black area denotes welded head bracket.

DF-U - Denotes muffler used primarily as Direct Fit, but is also Universal.

U-DF - Denotes muffler used primarily as Universal, but is also Direct Fit.

DF - Direct Fit Muffler

U - Universal Muffler

HS - Denotes Heat Shield is on muffler.

GENERAL MOTORS

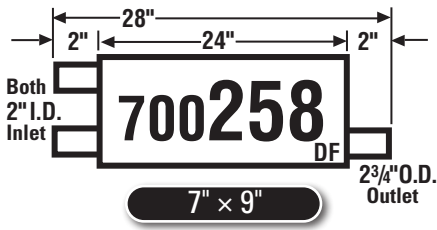

- 99-00 Escalade, Denali
- 96-99 C1500, C2500, K1500, K2500
- 96-00 Tahoe/Yukon

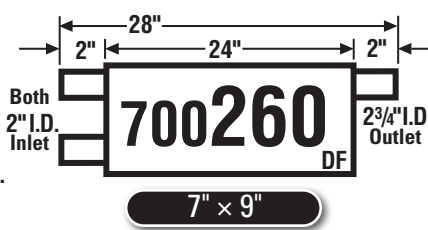

- 96-00 C1500, C2500, K1500, K2500, Suburban, Tahoe, Yukon

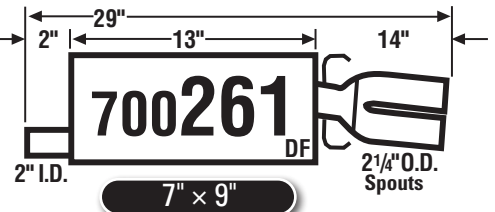

- 95-99 Lumina, Monte Carlo, Dual Exh. (Right)

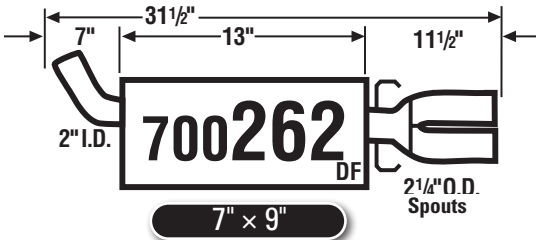

- 95-99 Lumina, Monte Carlo, Dual Exh. (Left)

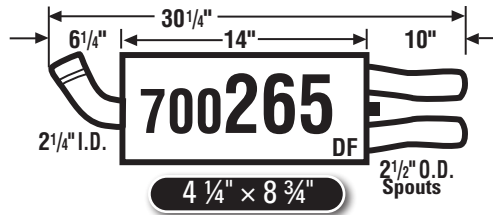

- 85-90 Corvette, exc. ZR1, Dual Exh. (Left)

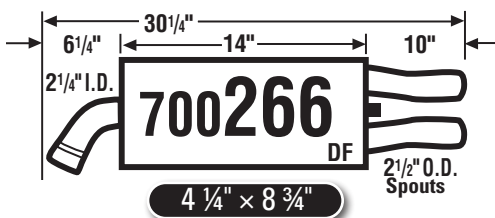

- 85-90 Corvette, exc. ZR1, Dual Exh. (Right)

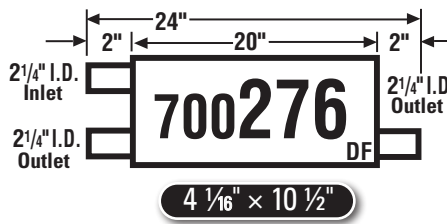

- 95-97 Camaro
- 91-92 Camaro, Firebird
- 96-97 Firebird

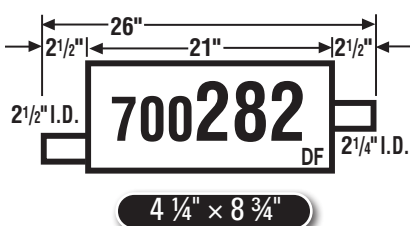

- 91-93 Park Avenue, exc. 92-93 Supercharged Eng.
- 92-93 98, Exc. Supercharged Eng.

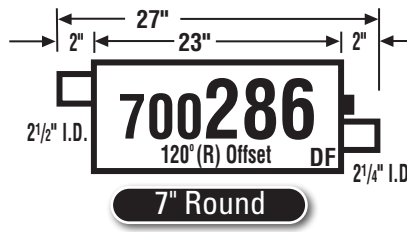

- 92-95 Lumina APV, Silhouette, Trans Sport

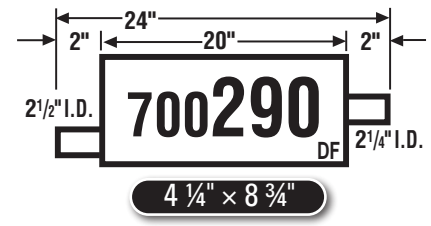

- 89-91 DeVille, Fleetwood

NOTE: Black area denotes welded head bracket.

DF-U - Denotes muffler used primarily as Direct Fit, but is also Universal.

U-DF - Denotes muffler used primarily as Universal, but is also Direct Fit.

DF - Direct Fit Muffler

U - Universal Muffler

HS - Denotes Heat Shield is on muffler.

GENERAL MOTORS



- 00-05 Blazer, Jimmy, Envoy
- 00-01 Bravada

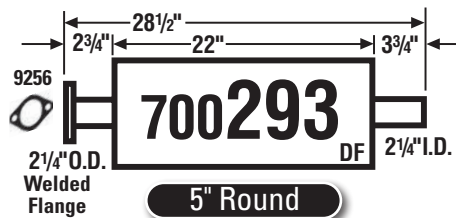

- 97-04 Regal, (Front)
- 00-05 Impala, (Front)
- 00-05 Monte Carlo, (Front)
- 97-08 Grand Prix, (Front)
- 05-08 Lacrosse (Front)
- 05-07 Allure (Front)

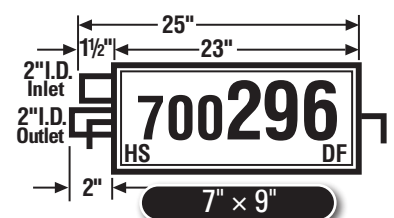

- 97-03 Malibu
- 04-05 Classic
- 97-99 Cutlass



- 00-05 Monte Carlo, Dual Exh. (Right)
- 97-08 Grand Prix, Dual Exh. (Right)
- 05-08 Lacrosse, Dual Exh. (Right)
- 05-07 Allure, Dual Exh. (Right)

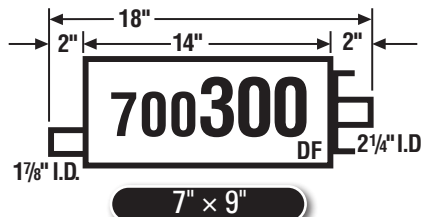

- 00-05 Monte Carlo, Dual Exh. (Left)
- 97-08 Grand Prix, Dual Exh. (Left)
- 05-08 Lacrosse, Dual Exh. (Left)
- 05-07 Allure, Dual Exh. (Left)

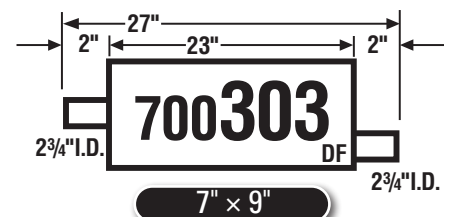

- 99-07 C1500/K1500 Silverado/ Sierra, Avalanche, Suburban, Tahoe, Yukon
- 99-00 C2500/K2500 Silverado/Sierra
- 02-05 Escalade

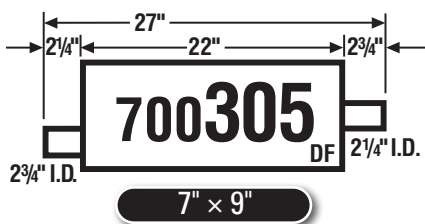

- 96-99 C1500/K1500, C2500/K2500

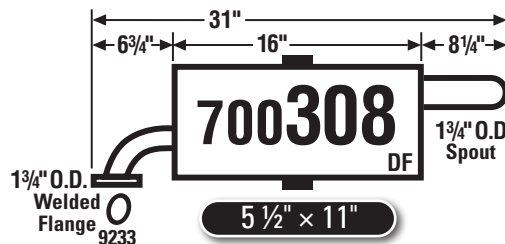

- 98-02 Chevrolet Prizm

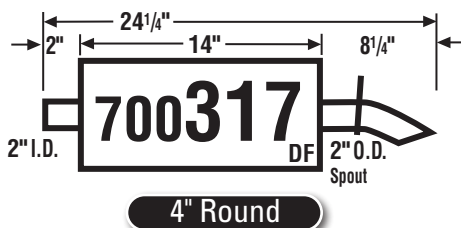

- 94-96 Fleetwood Brougham, Dual Exh (RWD) (Both Rear)

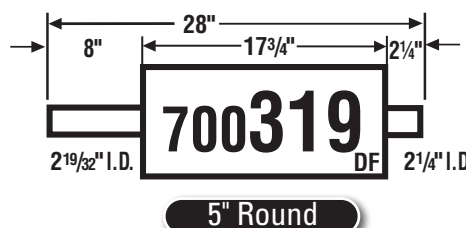

- 00-05 LeSabre/Bonneville (Front)
- 04-05 Park Avenue (Front)

NOTE: Black area denotes welded head bracket.

DF-U - Denotes muffler used primarily as Direct Fit, but is also Universal.

U-DF - Denotes muffler used primarily as Universal, but is also Direct Fit.

DF - Direct Fit Muffler

U - Universal Muffler

HS - Denotes Heat Shield is on muffler.

GENERAL MOTORS

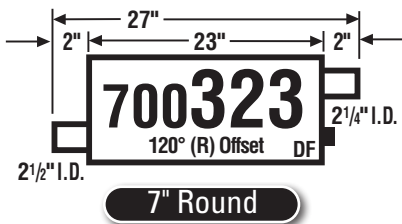

1996 Lumina APV, Silhouette, Trans Sport

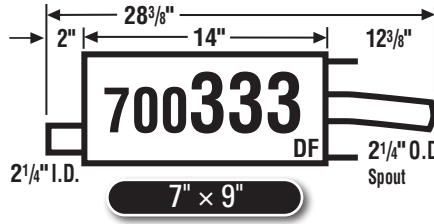

97-05 Century, 3.1L
00-05 Monte Carlo, 3.4L
97-08 Grand Prix

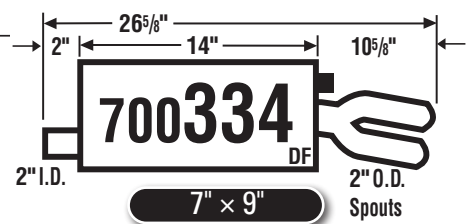

95-96 Regal, 3.8L

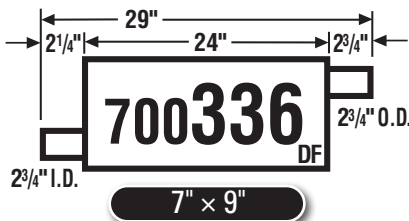

93-95 C/K1500, C/K2500, C/K3500 Turbo Diesel

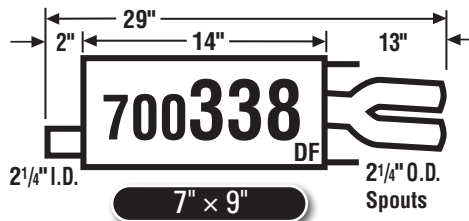

97-04 Regal

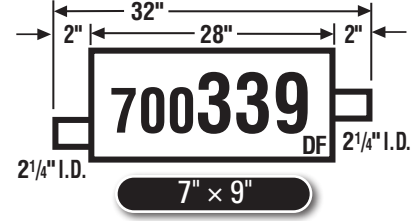

99-01 Montana (Ext. W.B.)
97-01 Silhouette (Ext. W.B.)
97-98 Trans Sport (Ext. W.B.)
97-01 Venture (Ext. W.B.)

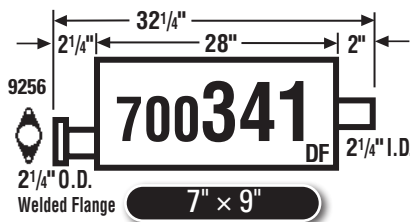

99-01 Montana (Std. W.B.)
97-99 Silhouette (Std. W.B.)
97-98 Trans Sport (Std. W.B.)
97-01 Venture (Std. W.B.)

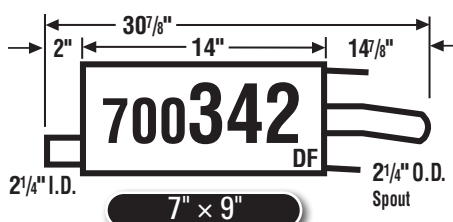

00-05 Impala

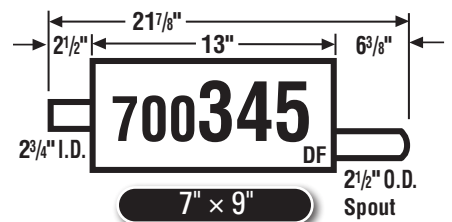

02-04 Bravada (Rear)
04-07 Rainier (Rear)
02-09 Trailblazer, Envoy (Rear)

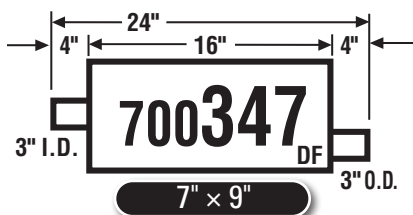

90-95 C3500/K3500 7.4L Chassis Cab

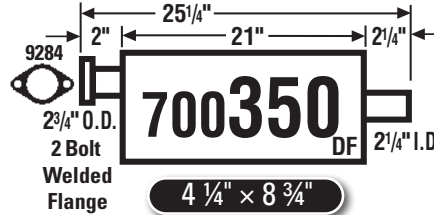

00-05 Blazer/Jimmy S/T 2-Dr.

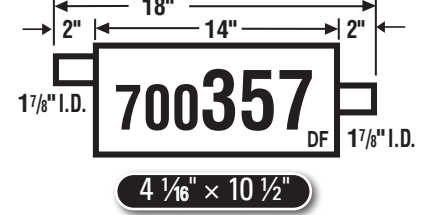

95-99 Aurora, Riviera, Dual Exh (Both Rear)
97-05 Park Avenue, Dual Exh (Both Rear)

NOTE: Black area denotes welded head bracket.

DF-U - Denotes muffler used primarily as Direct Fit, but is also Universal.

U-DF - Denotes muffler used primarily as Universal, but is also Direct Fit.

DF - Direct Fit Muffler

U - Universal Muffler

HS - Denotes Heat Shield is on muffler.

DIRECT FITS

MAXIMUM **TMSL**

GENERAL MOTORS

MSL MUFFLER BY APPLICATION

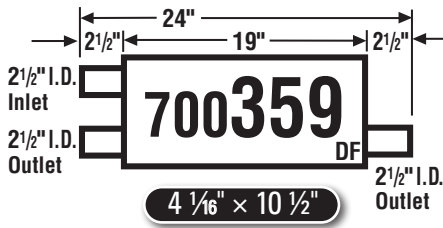

83-90 Camaro Z28, IROC-Z, Firebird, Trans AM

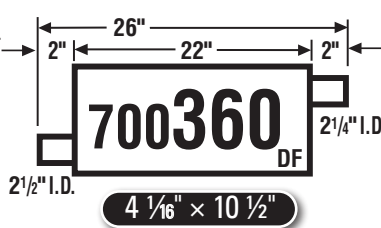

91-93 Riviera
90-92 Eldorado/Seville
91-92 Toronado

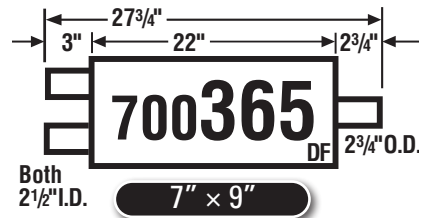

96-00 C/K2500, C/K3500 Old Body Style, 155.5" W.B.

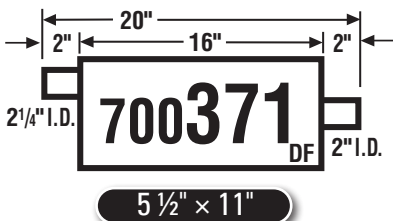

97-05 Park Avenue (Rear)

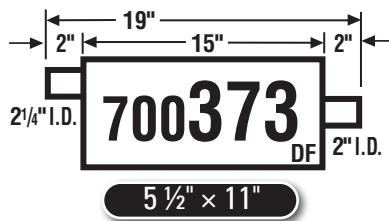

00-05 Bonneville, LeSabre (Rear)

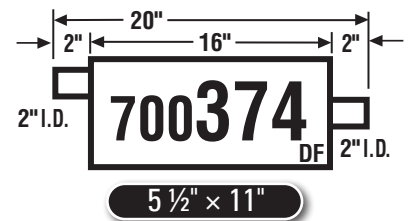

00-05 Deville, Dual Exh (Both)
98-03 Seville, Dual Exh (Both)
06-11 DTS, Dual Exh (Both)

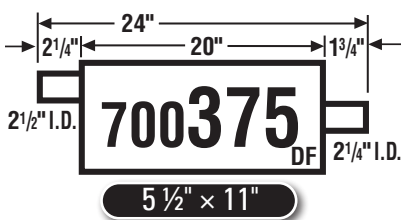

92-93 DeVille
1992 Fleetwood

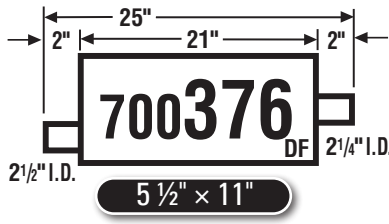

05-09 Equinox
96-04 S10/S15, 6 cyl. (96 Manual Trans.)
06-09 Torrent
02-07 Vue

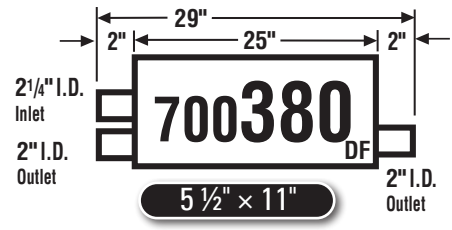

96-99 Bonneville SSE

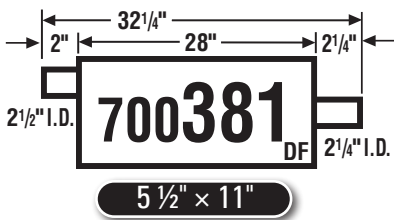

1996 S10/S15 6 cyl. (Auto. Trans.)
96-97 T10/T15 6 cyl.

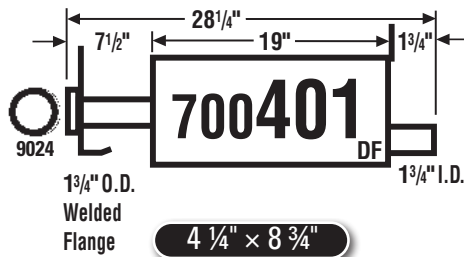

99-03 Tracker 2-Dr. Models

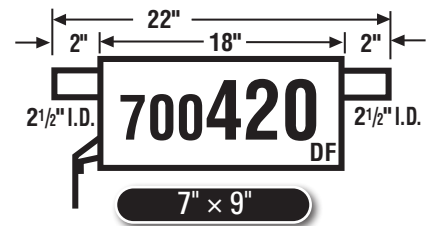

04-12 Colorado/Canyon

NOTE: Black area denotes welded head bracket.

DF-U - Denotes muffler used primarily as Direct Fit, but is also Universal.

U-DF - Denotes muffler used primarily as Universal, but is also Direct Fit.

DF - Direct Fit Muffler

U - Universal Muffler

HS - Denotes Heat Shield is on muffler.

GENERAL MOTORS

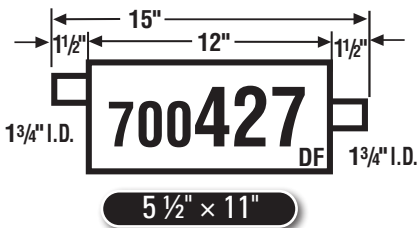

04-07 Malibu Sedan & Maxx
2008 Malibu Classic

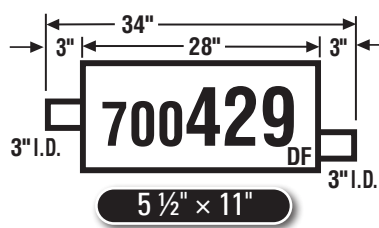

02-04 Bravada (Front)
04-07 Rainier (Front)
02-09 Trailblazer, Envoy (Front)

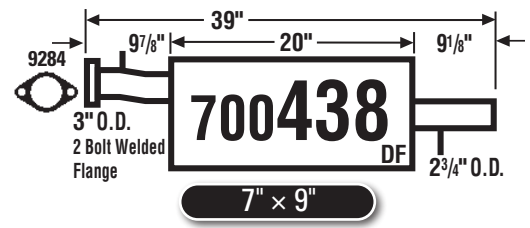

00-02 G10/G1500, G20/G2500, Express/Savana

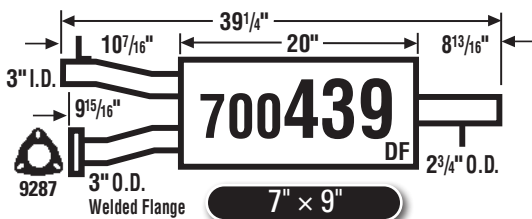

96-00 G10/G1500 (96-99), G20/G2500 (96-99), G30/G3500 (96-00), Express/Savana

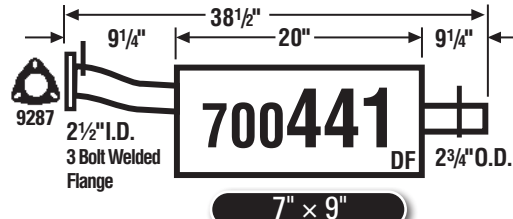

96-00 G10/G1500, G20/G2500, Express/Savana

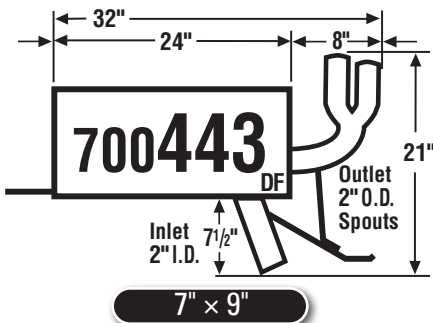

99-04 Oldsmobile Alero
99-05 Pontiac Grand Am, exc. GT w/ Dual Exhaust

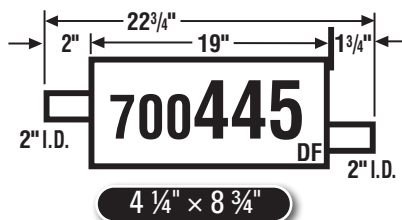

99-03 Tracker, 4 cyl., 4-Dr.
01-04 Tracker, 6 cyl., 4-Dr.

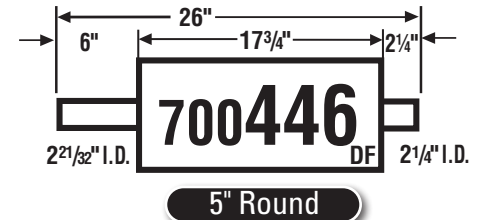

95-99 Aurora, Riviera (Front)
97-05 Park Avenue (Front)

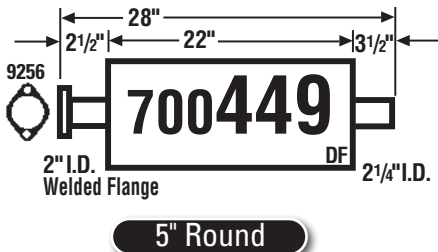

06-11 Impala, 3.5L (Front)
06-07 Monte Carlo, 3.5L (Front)

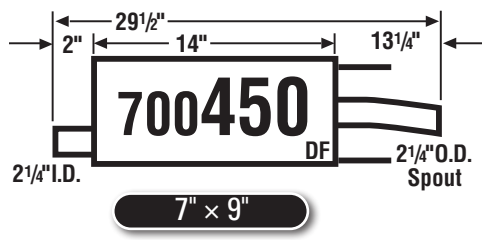

06-11 Impala, 3.5L (Rear)
06-07 Monte Carlo, 3.5L (Rear)

NOTE: Black area denotes welded head bracket.

DF-U - Denotes muffler used primarily as Direct Fit, but is also Universal.

U-DF - Denotes muffler used primarily as Universal, but is also Direct Fit.

DF - Direct Fit Muffler

U - Universal Muffler

HS - Denotes Heat Shield is on muffler.

DIRECT FITS

MAXIMUM **MSL**

GENERAL MOTORS

MSL MUFFLER BY APPLICATION

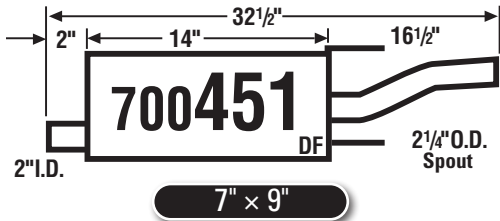

- 06-11** Impala, 3.9L (Right)
- 06-09** Impala SS, 5.3L (Right)
- 12-16** Impala, 3.6L (Right)

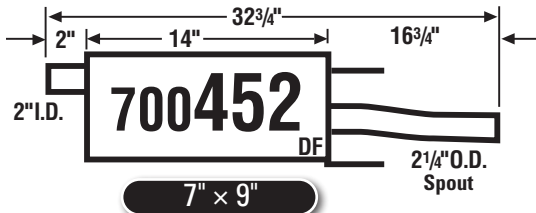

- 06-11** Impala, 3.9L (Left)
- 06-09** Impala SS, 5.3L (Left)
- 12-16** Impala, 3.6L (Left)

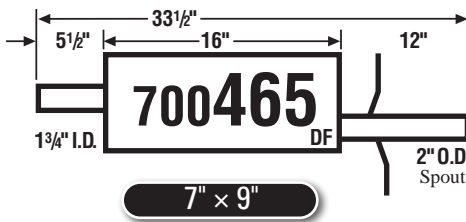

- 05-10** Cobalt, 2.2L
- 05-06** G5 Pursuit, 2.2L (Canada Only)
- 07-10** G5, 2.2L

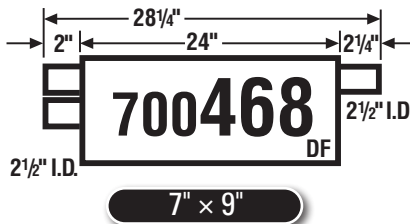

- 02-06** Escalade, 6.0L (exc. ESV or EXT Models or Models w/ 20" Wheels)
- 01-06** Tahoe/Yukon Denali, 6.0L (exc. XL Models)
- 03-06** Hummer H2, 6.0L

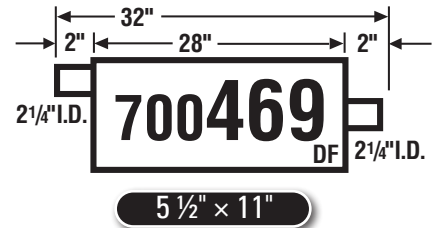

- 05-07** Terraza
- 05-08** Uplander
- 02-05** Venture
- 02-04** Silhouette
- 02-08** Montana
- 05-07** Relay

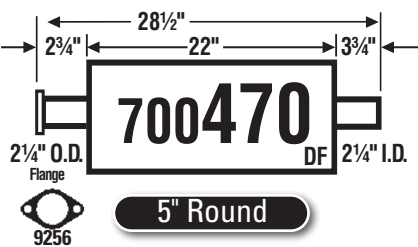

- 05-07** Buick, Allure
- 05-09** Buick, Lacrosse

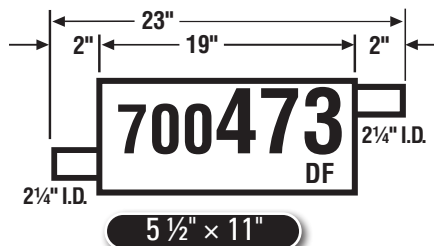

- 08-17** Buick, Enclave, V6-3.6L
- 09-17** Chevrolet, Traverse, V6-3.6L
- 07-17** GMC, Acadia, V6-3.6L



- 08-12** Chevrolet, Malibu, L4-2.4L
- 08-10** Pontiac, G6, L4-2.4L

NOTE: Black area denotes welded head bracket.

DF-U - Denotes muffler used primarily as Direct Fit, but is also Universal.

U-DF - Denotes muffler used primarily as Universal, but is also Direct Fit.

DF - Direct Fit Muffler

U - Universal Muffler

HS - Denotes Heat Shield is on muffler.

GENERAL MOTORS

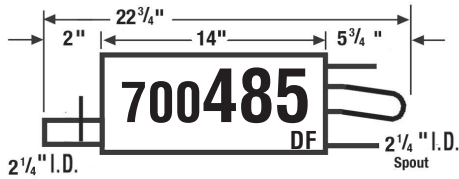

7" x 9"

- 05-07** Buick, Allure, V6-3.8L, Rear
- 05-09** Buick, Lacrosse, V6-3.8L, Rear

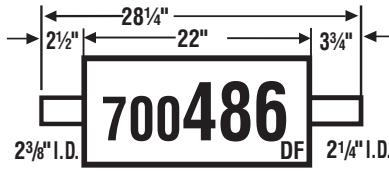

5" Round

- 08-12** Chevrolet, Malibu, V6-3.6L
- 08-10** Pontiac, G6, V6-3.5L
- 08-09** Pontiac, G6, V6-3.6L

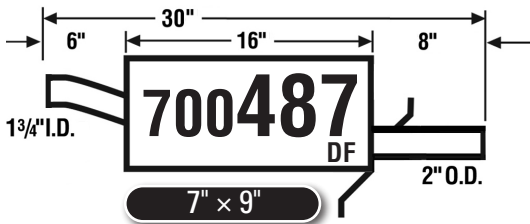

7" x 9"

- 06-11** Chevrolet, HHR, L4-2.2L

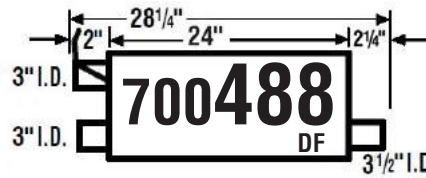

8 1/2" x 11 1/2"

- 01-06** Chevrolet/Silverado 2500HD, GMC/Sierra 2500HD, V8-6.0L, V8-8.1L
- 04-06** Chevrolet/Silverado 3500, GMC/Sierra 3500, V8-6.0L, V8-8.1L

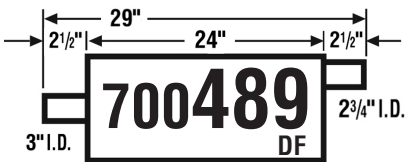

8 1/2" x 11 1/2"

- 07-13** Chevrolet/Silverado 1500, GMC/Sierra 1500, V6-4.3L, V8-4.8L, V8-5.3L

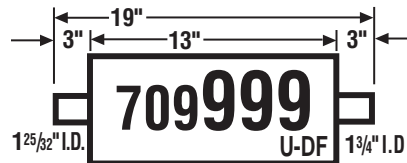

5" Round

- 88-89** LeMans (Front)

NOTE: Black area denotes welded head bracket.

DF-U - Denotes muffler used primarily as Direct Fit, but is also Universal.
U-DF - Denotes muffler used primarily as Universal, but is also Direct Fit.

DF - Direct Fit Muffler
U - Universal Muffler
HS - Denotes Heat Shield is on muffler.

DIRECT FITS

MAXIMUM **MSL**

HONDA



86-87 Civic Si Hatchback

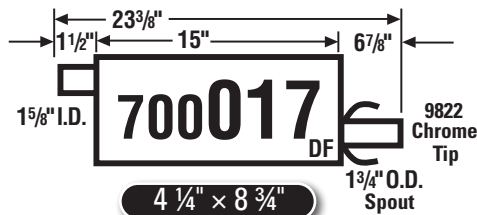

86-89 Accord 2-door Hatchback, Coupe, 4-door Sedan (Welded Ass'y. Available)

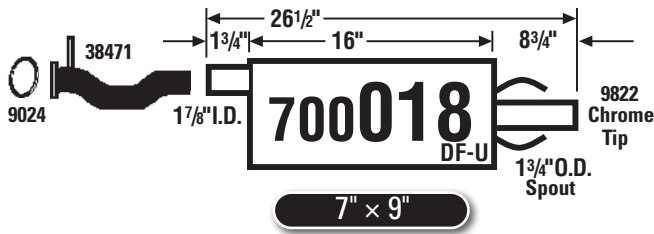

90-93 Accord DX, LX, 2-door Coupe, 4-door Sedan (Welded Ass'y. Available)

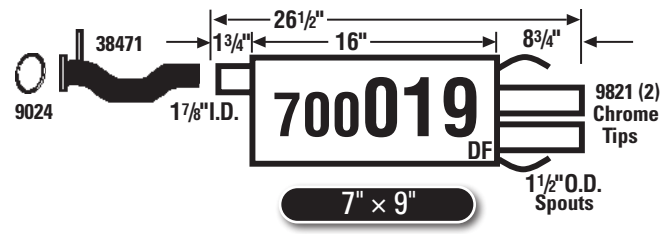

90-93 Accord EX, SE 4-door Sedan, (1991 & 1993), SE 2-door Coupe (1993) (Welded Ass'y. Available)

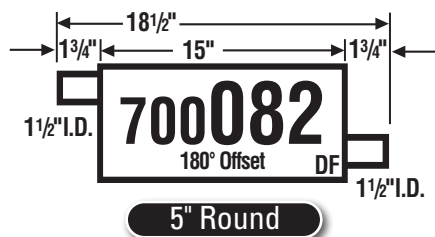

84-87 Civic Hatchback

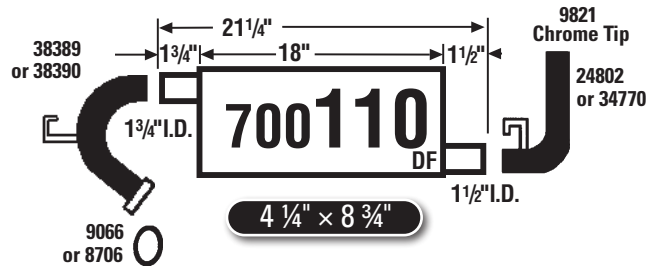

**88-91 Civic Hatchback, Sedan, DX, LX
88-91 Civic STD Hatchback, Sta. Wag., Wagon, CRX, HF, CRX DX**

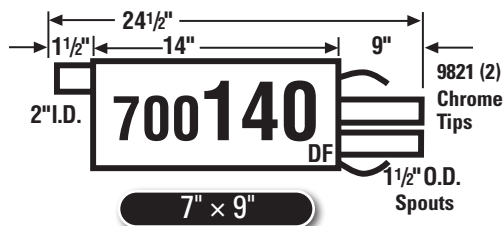

**90-91 Prelude Si
88-89 Prelude, w/ Fuel Inj.**

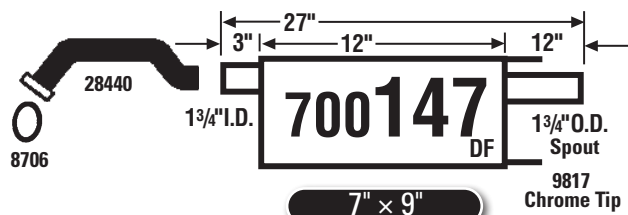

**92-00 Civic EX, Coupe (93-00), Sedan (92-00)
96-98 Civic All Models, exc. Ex
92-95 Civic DX, LX, Coupe, Sedan, CX, VX Hatchback (Welded Ass'y Available)**

NOTE: Black area denotes welded head bracket.

DF-U - Denotes muffler used primarily as Direct Fit, but is also Universal.

U-DF - Denotes muffler used primarily as Universal, but is also Direct Fit.

DF - Direct Fit Muffler

U - Universal Muffler

HS - Denotes Heat Shield is on muffler.

HONDA

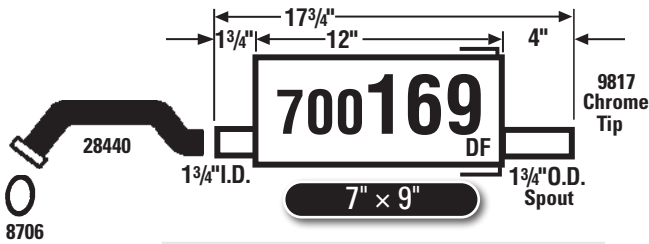

92-00 Civic, Hatchback
(Welded Ass'y Available)

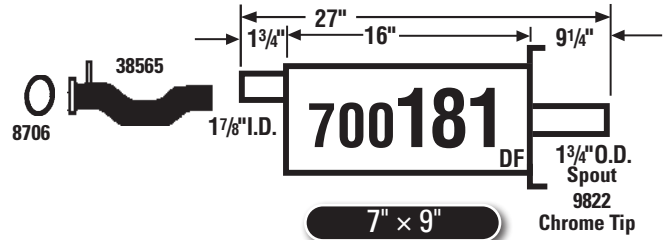

94-97 Accord DX, LX
(Welded Ass'y Available)

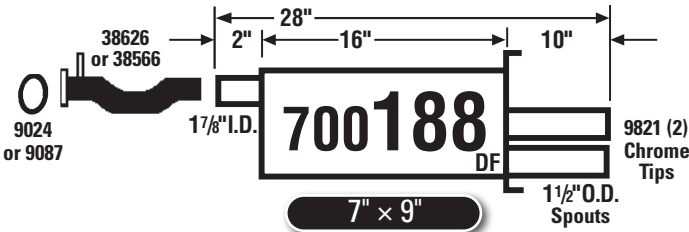

94-97 Accord EX, LX, 2-Dr. Coupe, 4-Dr. Sedan (Welded Assembly Available)

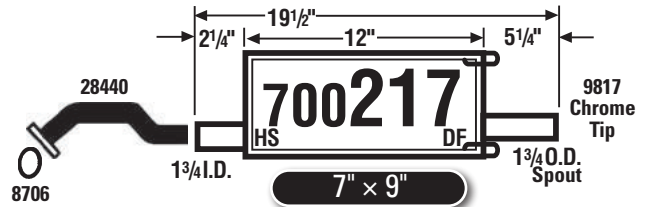

93-95 Civic Del Sol S

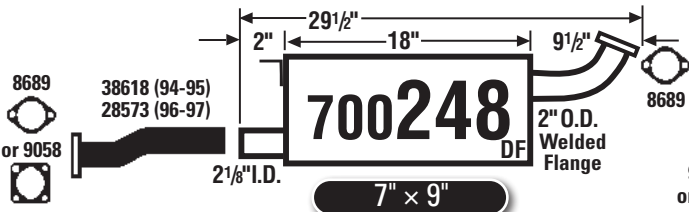

94-97 Passport

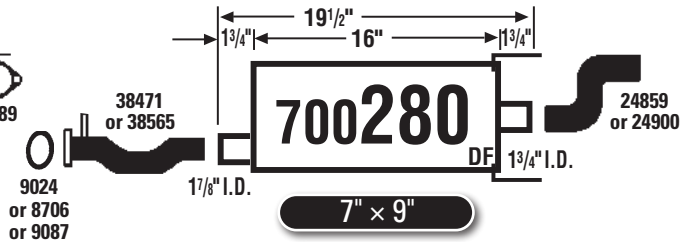

91-97 Accord LX; Sta. Wag.

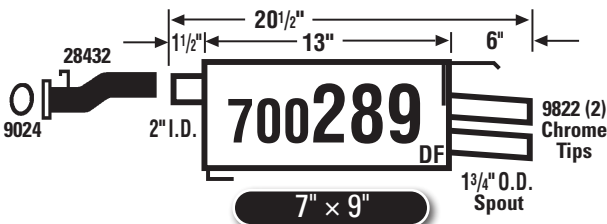

92-96 Prelude, All Models

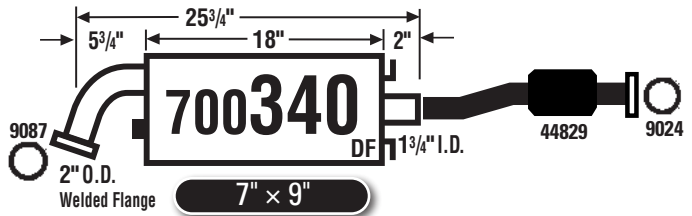

95-98 Odyssey (Front)

NOTE: Black area denotes welded head bracket.

DF-U - Denotes muffler used primarily as Direct Fit, but is also Universal.

U-DF - Denotes muffler used primarily as Universal, but is also Direct Fit.

DF - Direct Fit Muffler

U - Universal Muffler

HS - Denotes Heat Shield is on muffler.

DIRECT FITS

MAXIMUM **TMSL**

HONDA

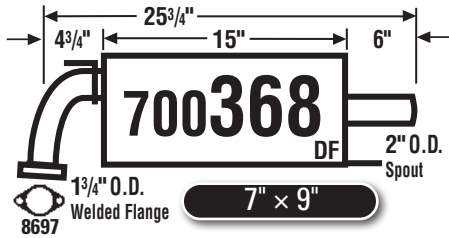

98-02 Accord Coupe & Sedan
6 cyl., Dual Exh (Right)

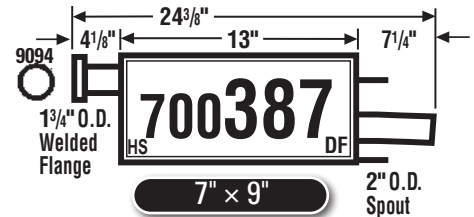

97-01 CRV

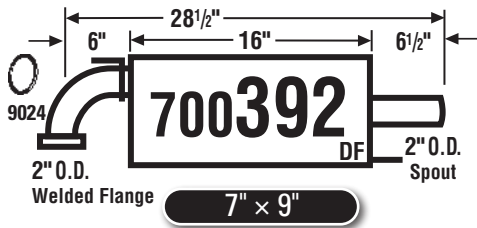

98-02 Accord, DX, LX, EX, SE

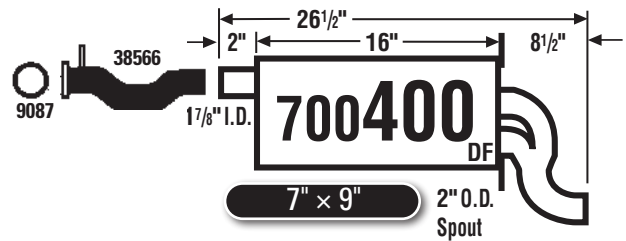

94-95 Accord EX Sta. Wagon

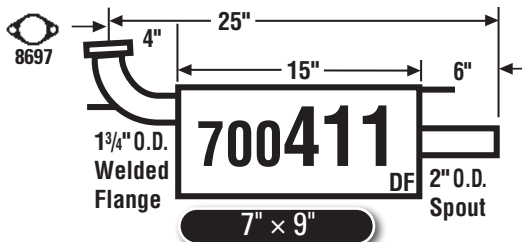

98-02 Accord Coupe & Sedan
6 cyl., Dual Exh (Left)

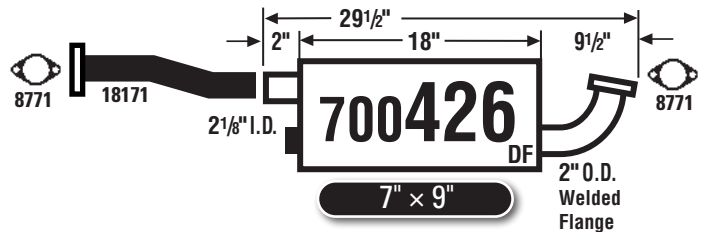

98-02 Passport

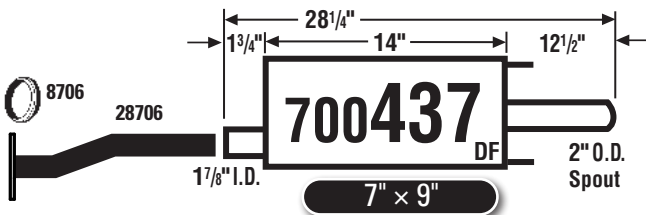

01-05 Civic DX, EX, GX, HX,
LX, Sedan & Coupe



04-99 Honda, Odyssey, V6-3.5L

MSL MUFFLER BY APPLICATION

NOTE: Black area denotes welded head bracket.

DF-U - Denotes muffler used primarily as Direct Fit, but is also Universal.

U-DF - Denotes muffler used primarily as Universal, but is also Direct Fit.

DF - Direct Fit Muffler

U - Universal Muffler

HS - Denotes Heat Shield is on muffler.

HYUNDAI

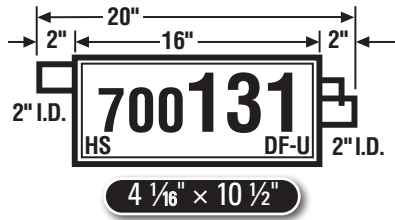

89-94 Sonata

INFINITI

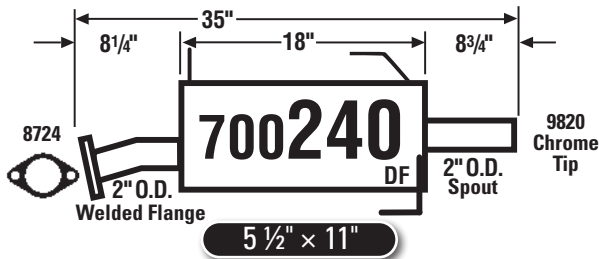

96-99 I30

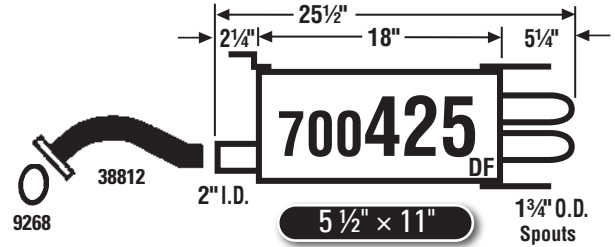

I30 (Exc. CA)

ISUZU



88-91 Trooper
86-90 Pickup
86-91 Trooper II



81-87 Pickup
84-85 Trooper II

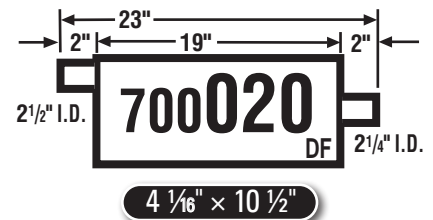

98-99 Hombre

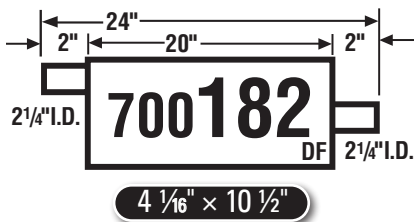

96-00 Hombre

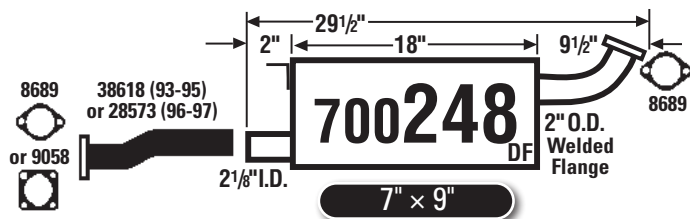

93-97 Rodeo

NOTE: Black area denotes welded head bracket.

DF-U - Denotes muffler used primarily as Direct Fit, but is also Universal.

U-DF - Denotes muffler used primarily as Universal, but is also Direct Fit.

DF - Direct Fit Muffler

U - Universal Muffler

HS - Denotes Heat Shield is on muffler.

DIRECT FITS

MAXIMUM **MMSL**

ISUZU

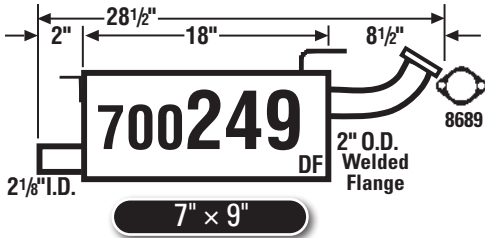

92-95 Trooper

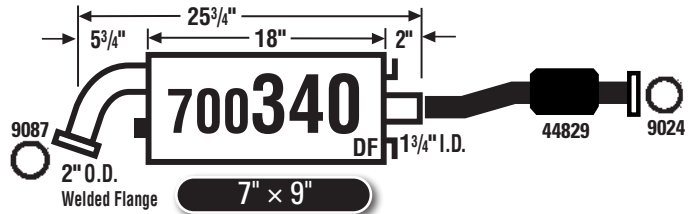

96-99 Oasis

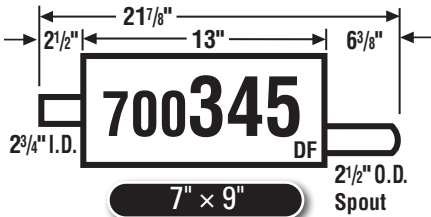

03-08 Ascender (Rear)

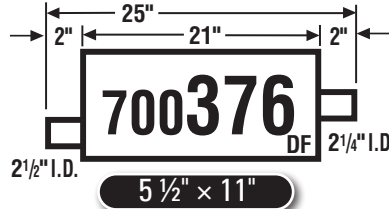

97-00 Hombre 6 cyl., 2 WD



06-08 I280/I350 Pickup

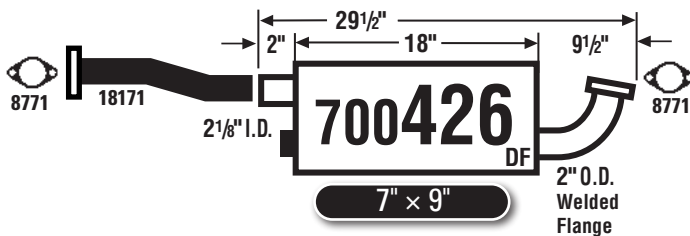

98-04 Rodeo (exc. Sport)

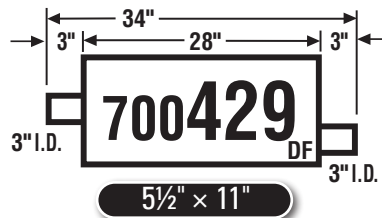

03-08 Ascender (Front)

MSL MUFFLER BY APPLICATION

NOTE: Black area denotes welded head bracket.

DF-U - Denotes muffler used primarily as Direct Fit, but is also Universal.

U-DF - Denotes muffler used primarily as Universal, but is also Direct Fit.

DF - Direct Fit Muffler

U - Universal Muffler

HS - Denotes Heat Shield is on muffler.

JEEP

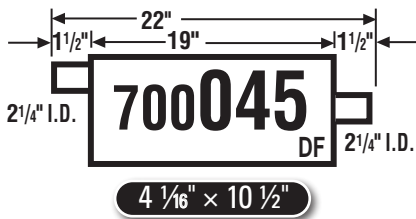

- 96-01 Cherokee
- 86-92 Wagoneer, Cherokee, Commanche (Reverse for some applications)

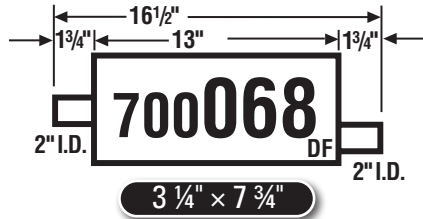

- 84-86 CJ7, CJ8, Scrambler
- 81-83 CJ5, CJ7, CJ8, All Models (1983), Calif. Models (81-82)

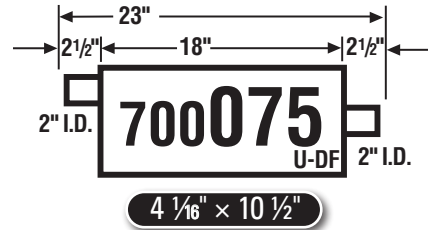

- 84-87 Wagoneer, Cherokee
- 1986 Commanche (Reverse for some applications)

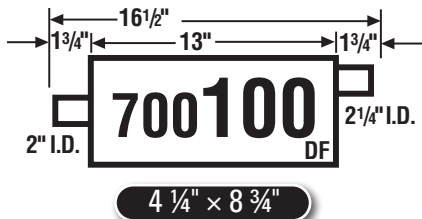

- 87-90 Wrangler

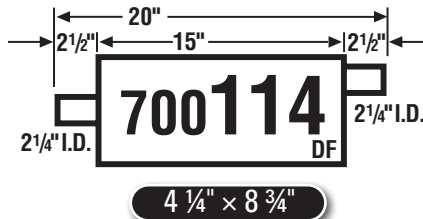

- 87-92 Wrangler

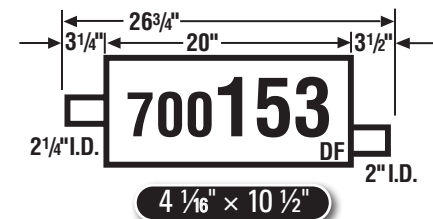

- 93-98 Grand Cherokee, Grand Wagoneer, 2 & 4 WD

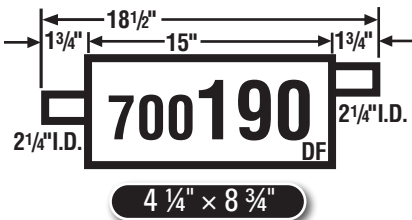

- 93-96 Wrangler

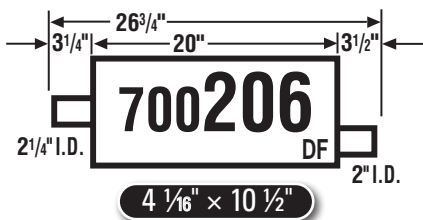

- 92-98 Grand Cherokee, 2 & 4 WD
- 93-95 Cherokee, 2 & 4 WD

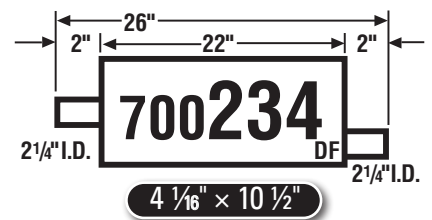

- 02-07 Liberty

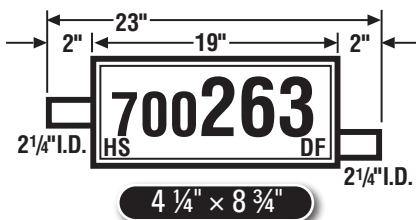

- 97-00 Wrangler

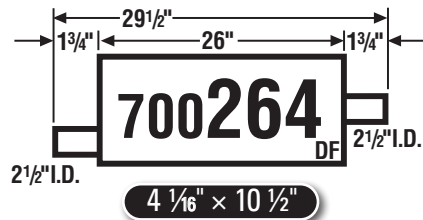

- 84-91 Grand Wagoneer
- 80-82 Series 10, Wagoneer, Cherokee
- 1983 Wagoneer, Cherokee

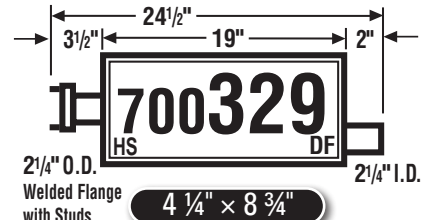

- 00-06 Wrangler

NOTE: Black area denotes welded head bracket.

DF-U - Denotes muffler used primarily as Direct Fit, but is also Universal.

U-DF - Denotes muffler used primarily as Universal, but is also Direct Fit.

DF - Direct Fit Muffler

U - Universal Muffler

HS - Denotes Heat Shield is on muffler.

DIRECT FITS

MAXIMUM **TMSL**

JEEP

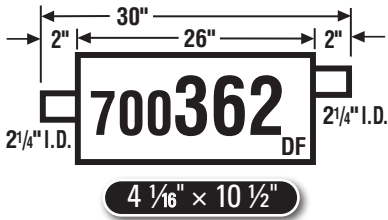

99-01 Grand Cherokee 6 cyl.

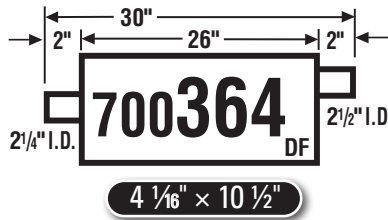

99-01 Grand Cherokee 8 cyl.

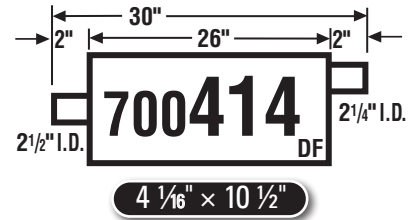

02-04 Grand Cherokee, 6 cyl.

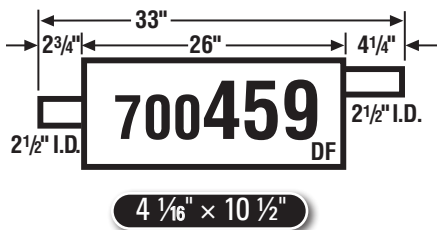

02-03 Grand Cherokee, 4.7L

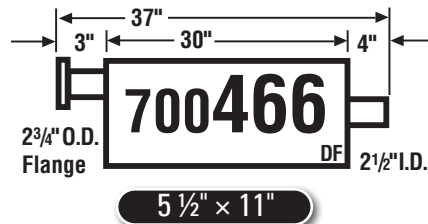

- 05-10 Grand Cherokee, 3.7L
- 05-10 Grand Cherokee, 4.7L & 5.7L
- 06-10 Commander, 3.7L
- 06-07 Commander, 4.7L & 5.7L

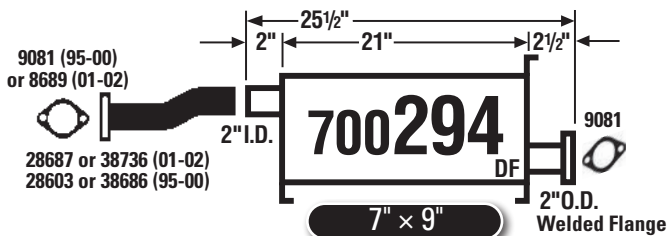

95-02 Sportage

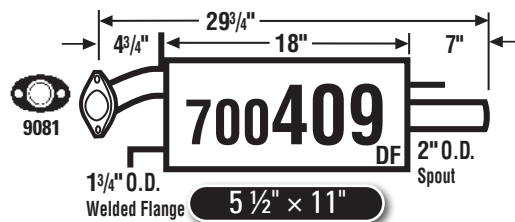

98-01 Sephia
00-04 Spectra Hatchback,
Sedan

MSL MUFFLER BY APPLICATION

NOTE: Black area denotes welded head bracket.

DF-U - Denotes muffler used primarily as Direct Fit, but is also Universal.
U-DF - Denotes muffler used primarily as Universal, but is also Direct Fit.

DF - Direct Fit Muffler
U - Universal Muffler
HS - Denotes Heat Shield is on muffler.

LEXUS

MSL MUFFLER BY APPLICATION

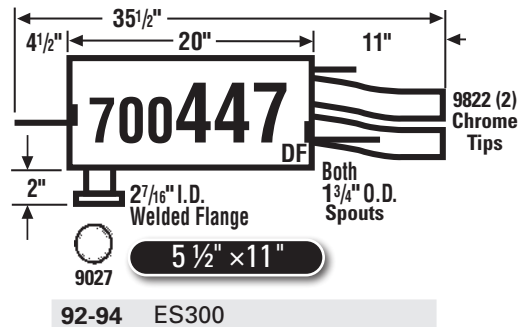
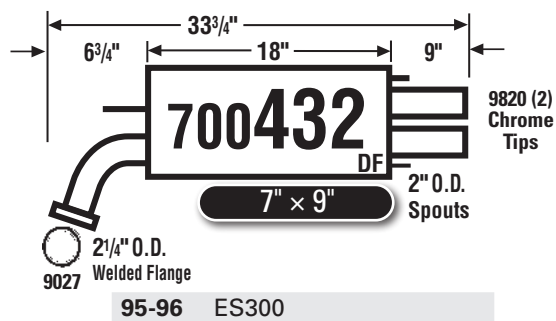
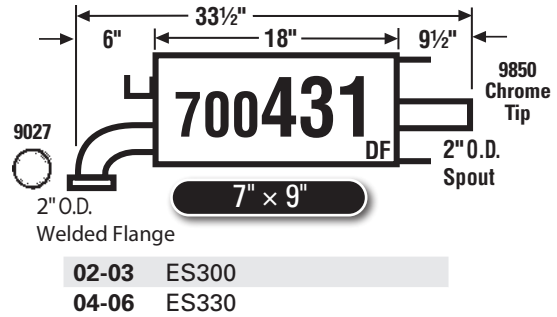
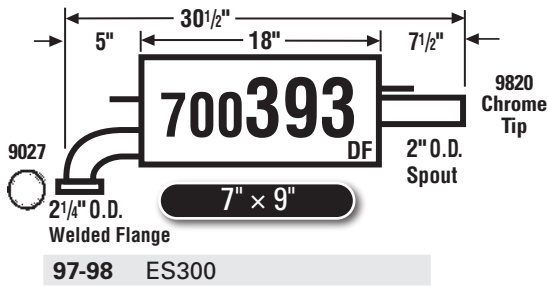

MAZDA

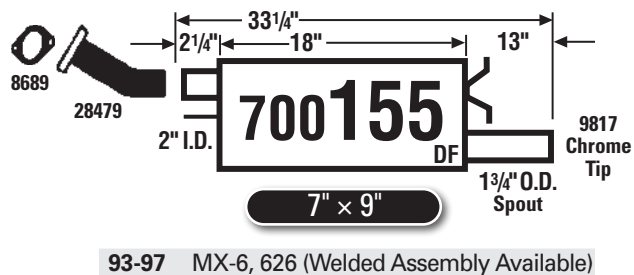
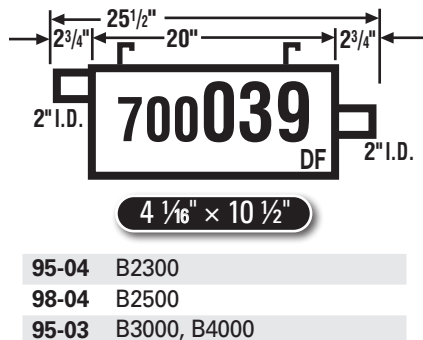
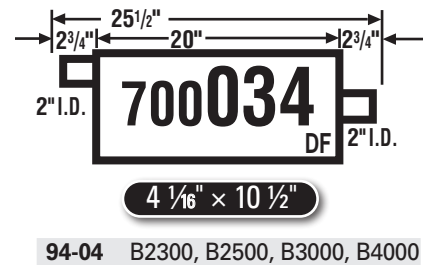
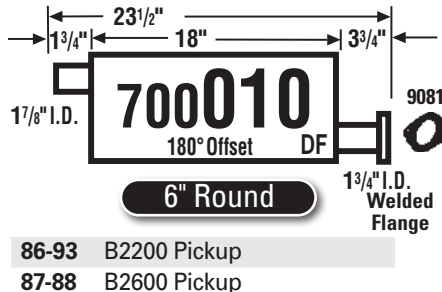
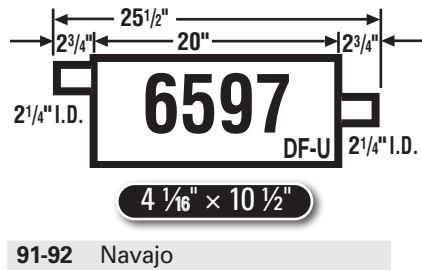

NOTE: Black area denotes welded head bracket.

DF-U - Denotes muffler used primarily as Direct Fit, but is also Universal.
U-DF - Denotes muffler used primarily as Universal, but is also Direct Fit.

DF - Direct Fit Muffler
U - Universal Muffler
HS - Denotes Heat Shield is on muffler.

DIRECT FITS

MAXIMUM **MSL**

MAZDA

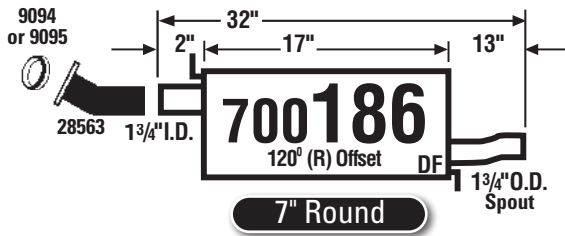

95-98 323 Protege



90-97 MX-5 Miata

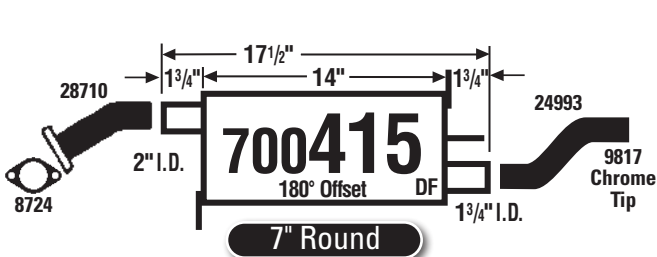

99-03 Protégé
(exc. Mazda Speed)

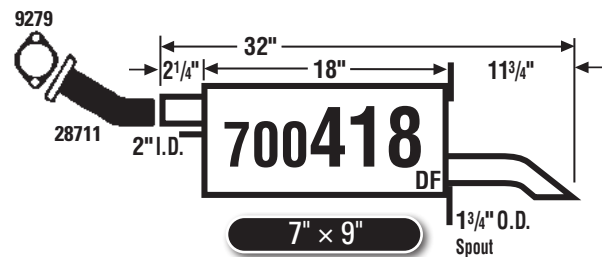

98-02 626 2.0L

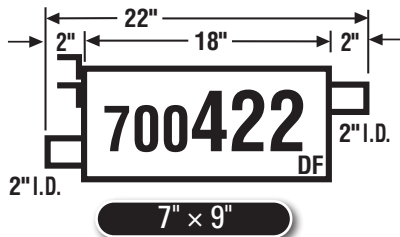

05-09 B2300
04-07 B3000
04-09 B4000

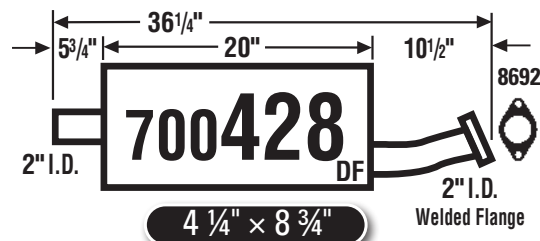

01-04 Tribute

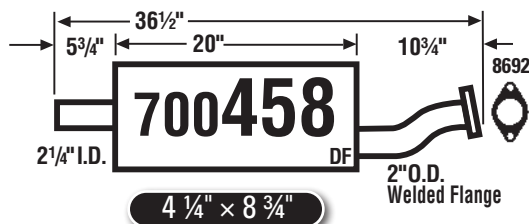

05-06 Tribute, 2.3L
2008 Tribute, 2.3L
05-06 Tribute, 3.0L
2008 Tribute, 3.0L

MSL MUFFLER BY APPLICATION

NOTE: Black area denotes welded head bracket.

DF-U - Denotes muffler used primarily as Direct Fit, but is also Universal.

U-DF - Denotes muffler used primarily as Universal, but is also Direct Fit.

DF - Direct Fit Muffler

U - Universal Muffler

HS - Denotes Heat Shield is on muffler.

NISSAN

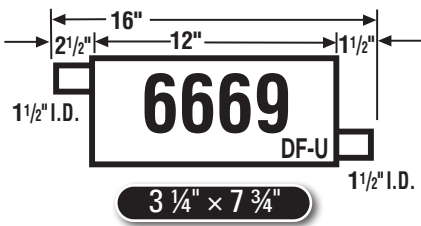

74-82 210, B210

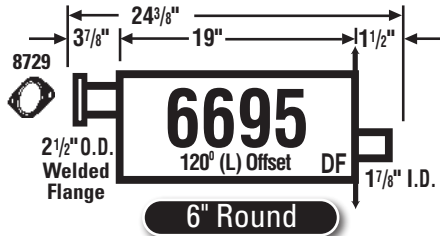

86-97 D21 (Hardbody)

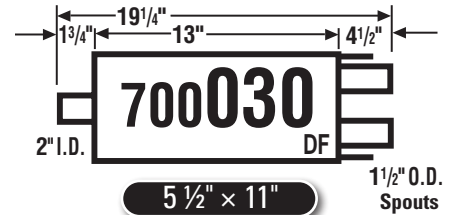

89-94 240SX (Rear)



84-89 300ZX

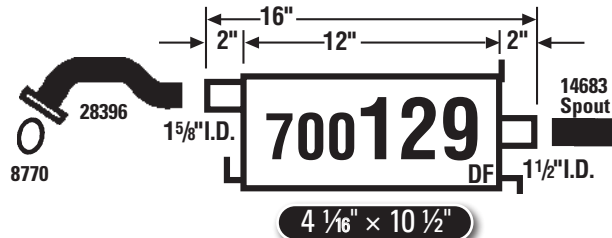

91-94 Sentra

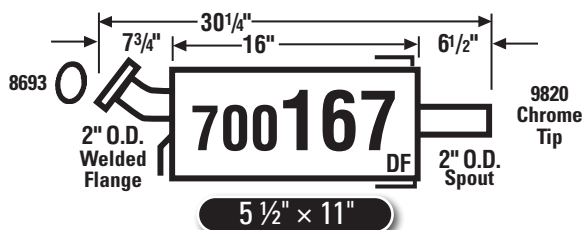

93-97 Altima

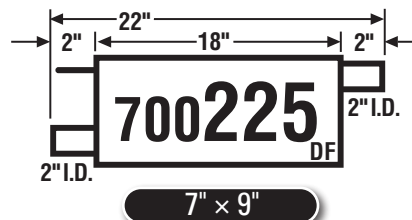

94-97 Quest

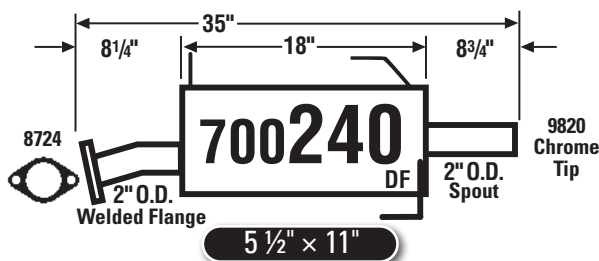

95-00 Maxima

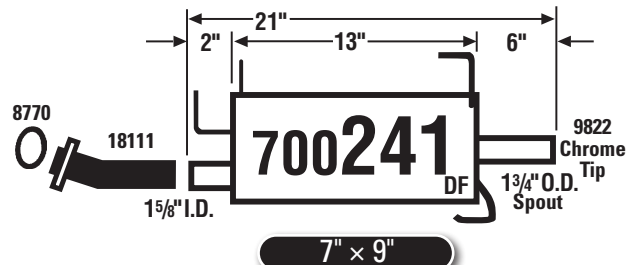

95-98 200SX

95-99 Sentra

NOTE: Black area denotes welded head bracket.

DF-U - Denotes muffler used primarily as Direct Fit, but is also Universal.

U-DF - Denotes muffler used primarily as Universal, but is also Direct Fit.

DF - Direct Fit Muffler

U - Universal Muffler

HS - Denotes Heat Shield is on muffler.

DIRECT FITS

MAXIMUM **TMSL**

NISSAN

MSL MUFFLER BY APPLICATION

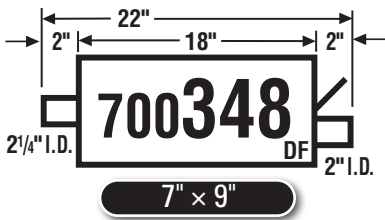

98-02 Quest (Rear)

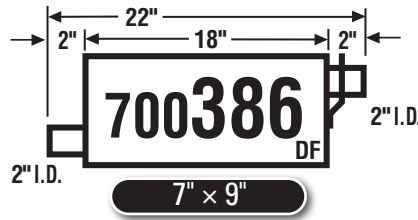

99-04 Frontier (99-02 6 cyl.)
(01-03 4 cyl.)
00-02 Xterra

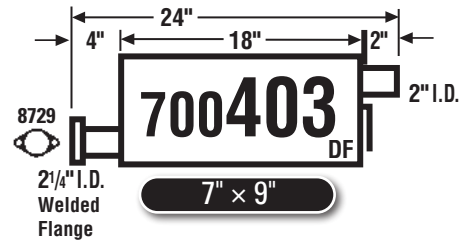

98-00 Frontier 4 cyl.

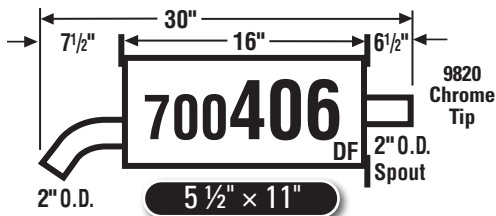

98-01 Altima

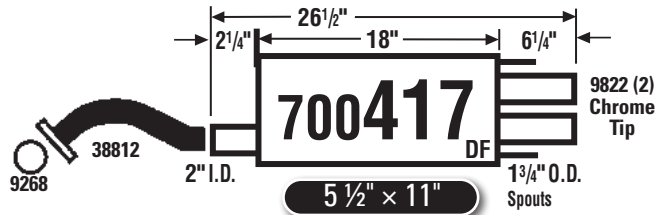

4/99-03 Maxima (exc. CA)

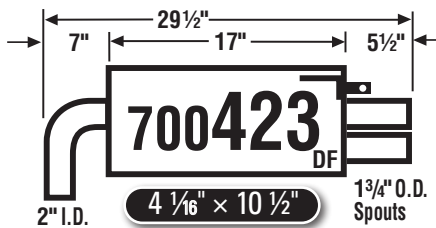

02-06 Altima, 4 cyl.

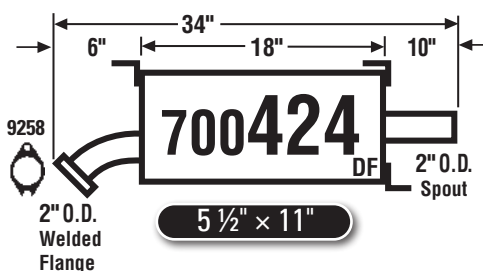

00-06 Sentra, 1.8L

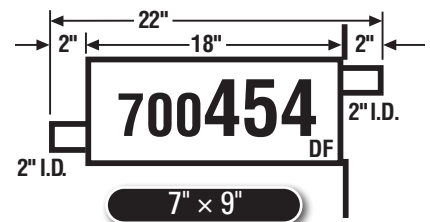

03-04 Xterra, 3.3L

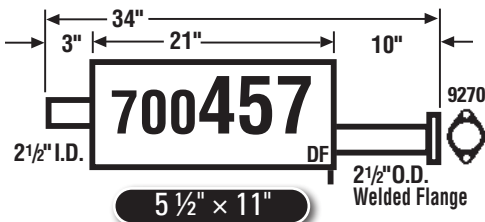

04-06 Titan Pickup King &
Crew Cab, 5.6L (XE, SE,
LE) (exc. Calif.)

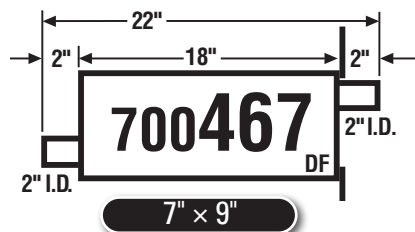

03-04 Frontier Crew-Cab, 3.3L

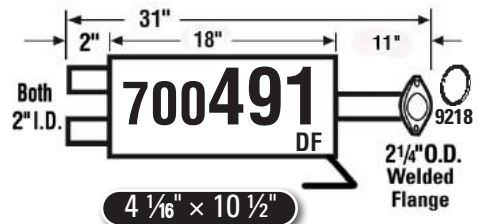

07-15 Titan, V8-5.6L

NOTE: Black area denotes welded head bracket.

DF-U - Denotes muffler used primarily as Direct Fit, but is also Universal.

U-DF - Denotes muffler used primarily as Universal, but is also Direct Fit.

DF - Direct Fit Muffler

U - Universal Muffler

HS - Denotes Heat Shield is on muffler.

SATURN

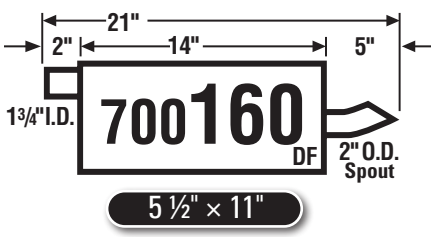

5 1/2" x 11"

91-02 Sedan, Coupe, Sta. Wag.

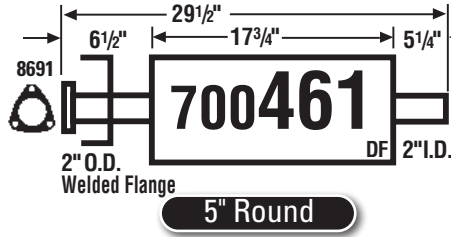

5" Round

00-05 L Series (Front)

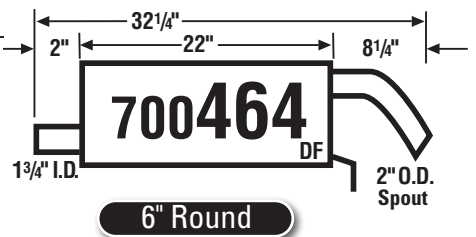

6" Round

03-07 ION, 2.2L

SUBARU



7" Round

90-94 Loyale
85-89 3-Dr. Coupe, 4-Dr. Sedan, Sta. Wag.

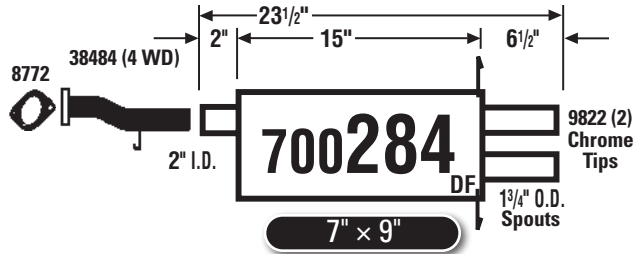

7" x 9"

90-94 Legacy 4-Dr. Sedan; exc. Turbo (through 2/94)

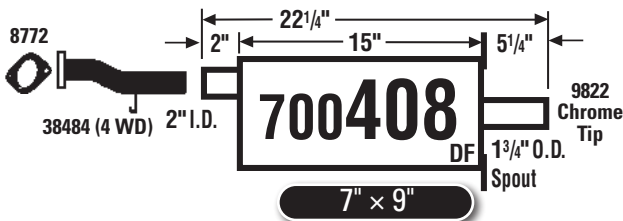

7" x 9"

3/94-99 Legacy 4 dr. Sedan, 2.2L

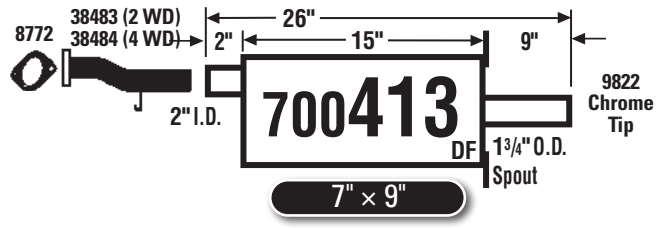

7" x 9"

96-99 Legacy Outback
94-99 Legacy Sta. Wagon, 2.2L

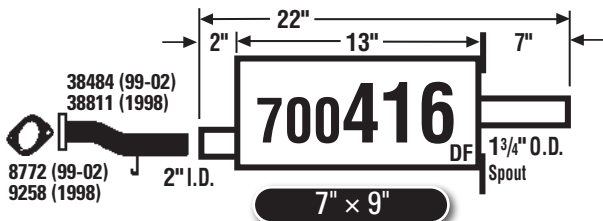

7" x 9"

98-2/02 Forester

NOTE: Black area denotes welded head bracket.

DF-U - Denotes muffler used primarily as Direct Fit, but is also Universal.
U-DF - Denotes muffler used primarily as Universal, but is also Direct Fit.

DF - Direct Fit Muffler
U - Universal Muffler
HS - Denotes Heat Shield is on muffler.

DIRECT FITS

MAXIMUM **TMSL**

SUZUKI

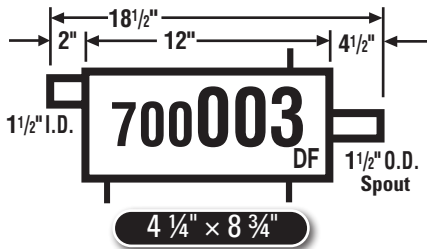

89-94 Suzuki Swift

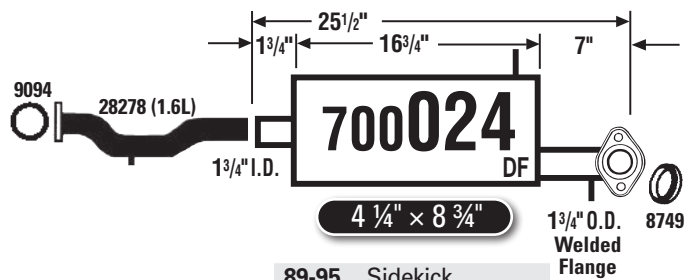

89-95 Sidekick

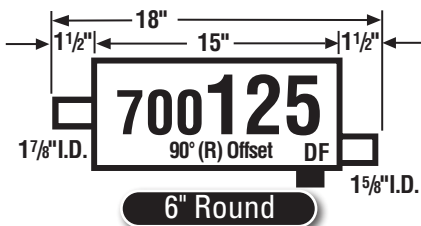

86-95 Samurai

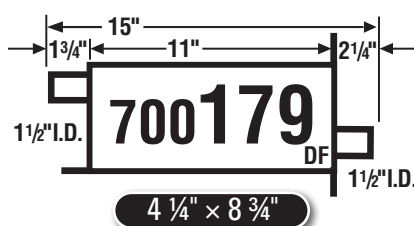

95-96 Suzuki Swift

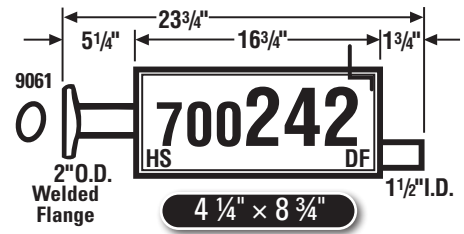

94-98 Sidekick; Convertible

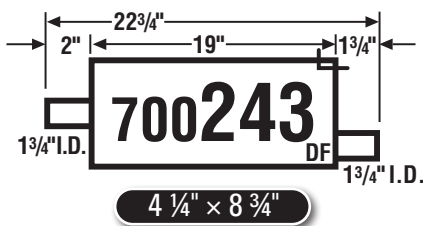

93-98 Sidekick; 4-Dr. Hardtop

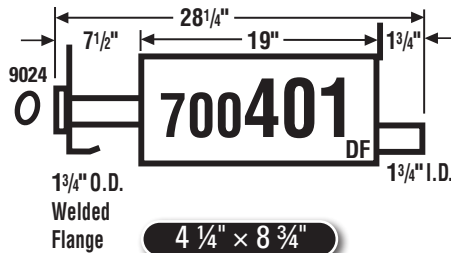

99-03 Vitara 2-Dr. Models

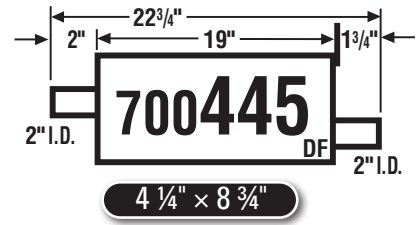

99-03 Vitara, 4 cyl., 4-Dr.
99-05 Grand Vitara, 6 cyl.

TOYOTA



79-95 Pickup, Cab & Chassis,
Camper, 4-Runner

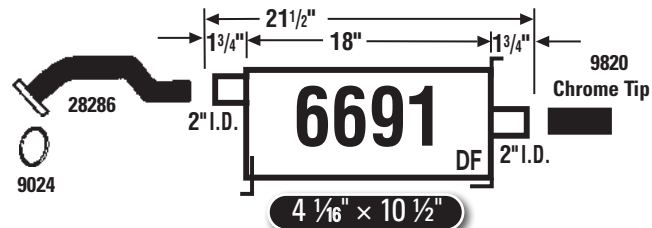

87-91 Camry (Welded Assembly Available)

NOTE: Black area denotes welded head bracket.

DF-U - Denotes muffler used primarily as Direct Fit, but is also Universal.

U-DF - Denotes muffler used primarily as Universal, but is also Direct Fit.

DF - Direct Fit Muffler

U - Universal Muffler

HS - Denotes Heat Shield is on muffler.

TOYOTA

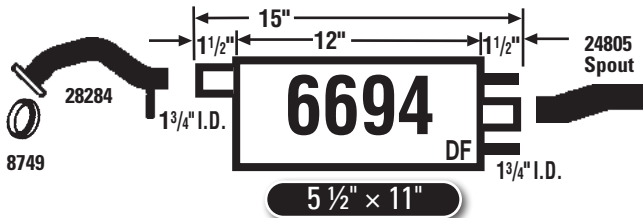

88-92 Corolla (Welded Assembly Available)

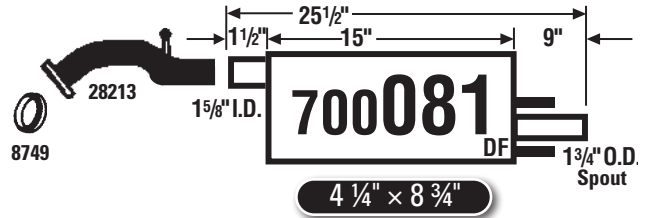

84-87 Corolla (exc. Diesel)

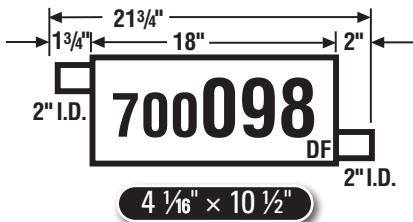

03-08 Matrix

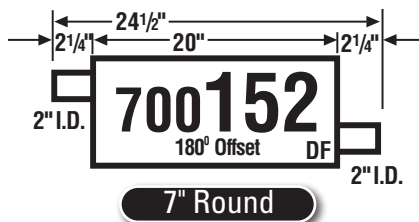

88-95 Pickup, Cab & Chassis, 4-Runner

93-97 T100 Pickup

95-04 Tacoma Pickup

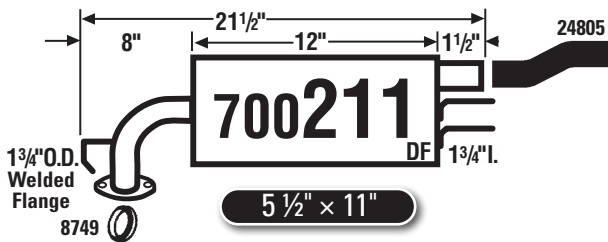

93-97 Corolla (Welded Assembly Available)

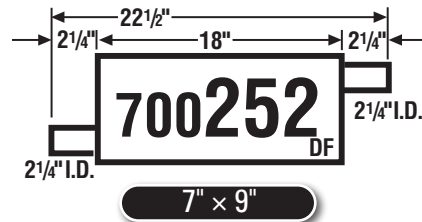

95-21 Tacoma Pickup

95-98 T100 Pickup

00-06 Tundra Pickup

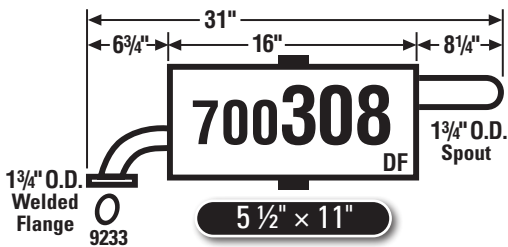

98-02 Corolla

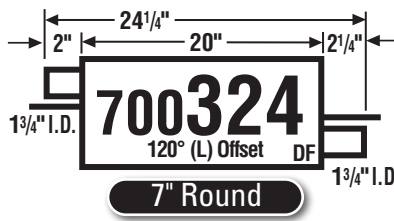

96-97 RAV-4



98-00 RAV-4

NOTE: Black area denotes welded head bracket.

DF-U - Denotes muffler used primarily as Direct Fit, but is also Universal.

U-DF - Denotes muffler used primarily as Universal, but is also Direct Fit.

DF - Direct Fit Muffler

U - Universal Muffler

HS - Denotes Heat Shield is on muffler.

DIRECT FITS

MAXIMUM **TMSL**

TOYOTA

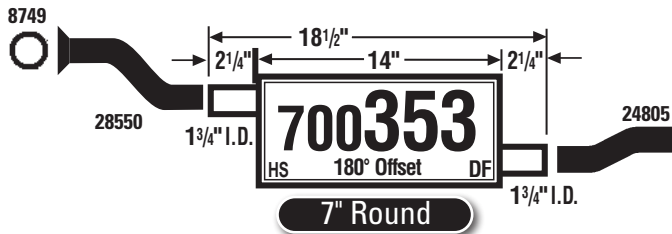

96-97 Paseo
95-98 Tercel

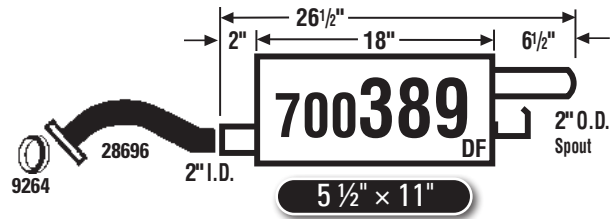

03-13 Corolla, 4-Dr. Sedan

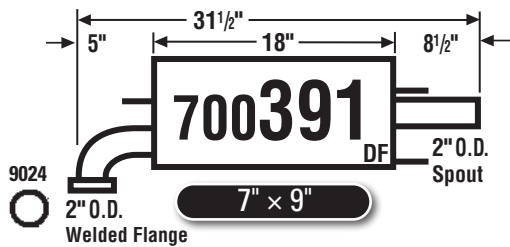

97-01 Camry Sedan, 4 cyl.
02-03 Solara, 4 cyl.

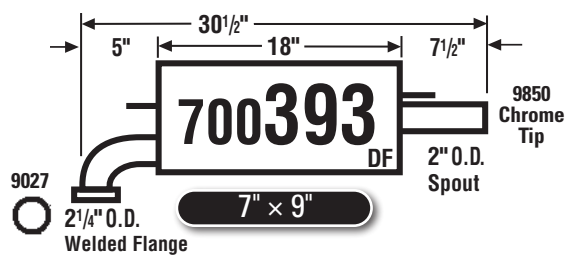

97-01 Camry Sedan 6 cyl.

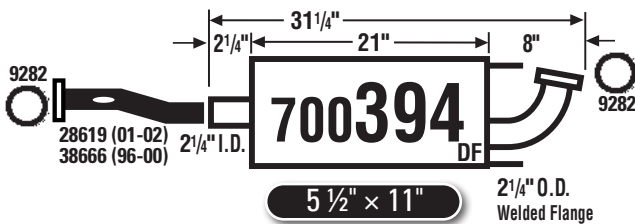

96-02 4 Runner 6 cyl. (exc. CA)

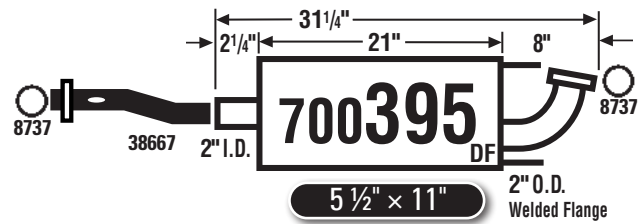

96-00 4 Runner 4 cyl.

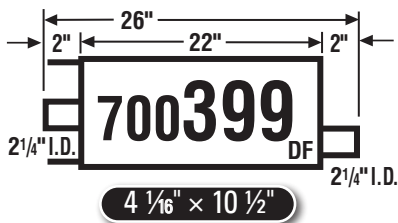

98-03 Sienna (exc. CA)

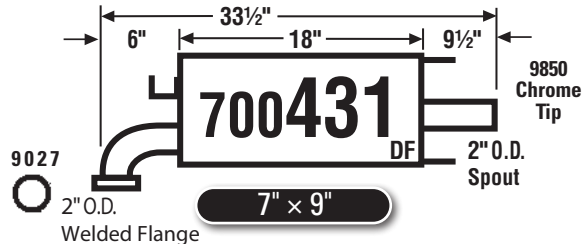

02-06 Camry
04-08 Solara

NOTE: Black area denotes welded head bracket.

DF-U - Denotes muffler used primarily as Direct Fit, but is also Universal.

U-DF - Denotes muffler used primarily as Universal, but is also Direct Fit.

DF - Direct Fit Muffler

U - Universal Muffler

HS - Denotes Heat Shield is on muffler.

TOYOTA

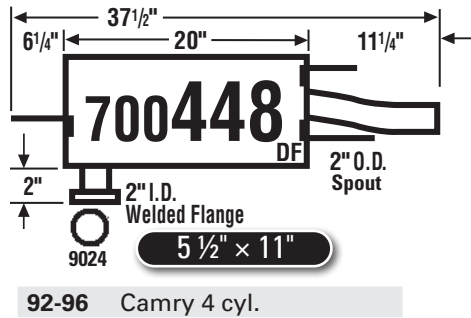
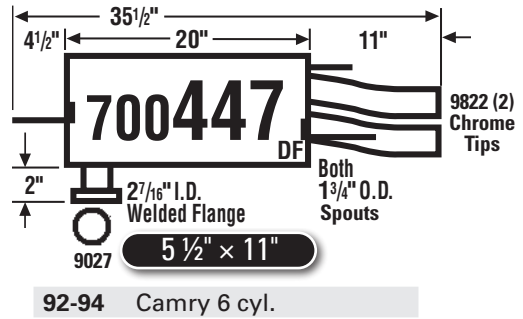
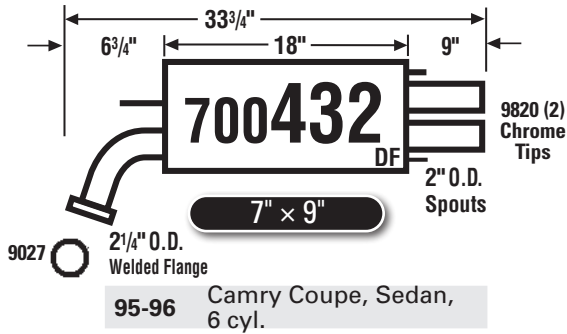

VOLKSWAGEN

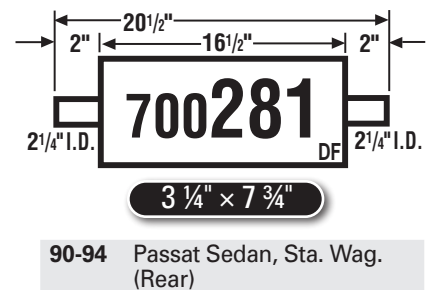
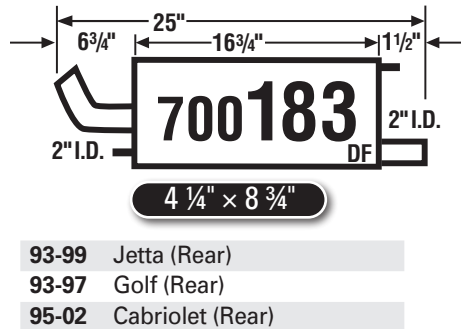
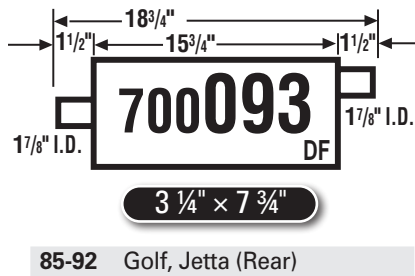

NOTE: Black area denotes welded head bracket.

DF-U - Denotes muffler used primarily as Direct Fit, but is also Universal.

U-DF - Denotes muffler used primarily as Universal, but is also Direct Fit.

DF - Direct Fit Muffler

U - Universal Muffler

HS - Denotes Heat Shield is on muffler.

DIRECT FITS

MAXIMUM **TMSL**

VOLVO

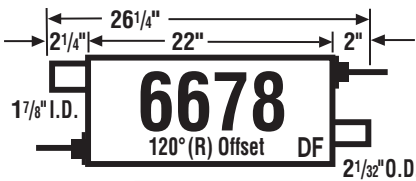

6" Round

- 84-93** 240 DL, GL
- 80-85** 2-Dr. (80-84), 4-Dr. Sedan, Sta. Wag.
- 75-80** 240 Series
- 75-76** 260 Series

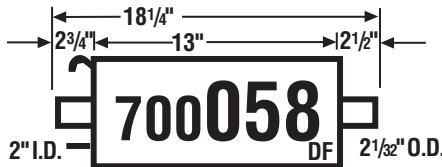

6" Round

- 84-93** 240 DL, GL (exc. turbo) (Front)
- 80-85** Sedan, Sta. Wag. (Front)
- 80-83** DL Sedan, Sta. Wag. (exc. turbo) (Front)
- 77-82** Series 242, 244, 245, 262, 264, 265 (Front)



6" Round

- 91-95** 940, 940 GLE (1991)
- 85-92** 740
- 83-90** 760, 780 (86-87)



4 1/4" x 8 3/4"

- 91-95** 940, 940 GLE (1991), (exc. turbo) (Rear)
- 88-92** 740, (exc. turbo); 760, 780 (88-91) (Rear)

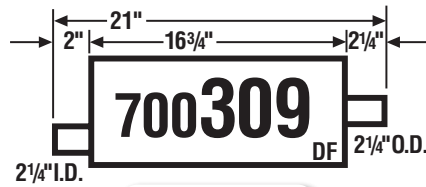

4 1/4" x 8 3/4"

- 88-92** 700 Series (Rear)
- 91-95** 900 Series (Rear)

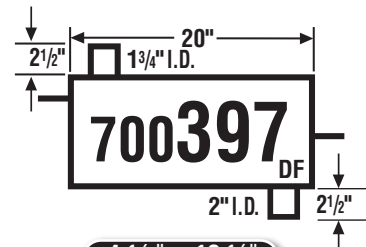

4 1/16" x 10 1/2"

- 93-97** 850 (exc. Turbo)
- 98-00** C70, S70, V70 (exc. Turbo)

MSL MUFFLER BY APPLICATION

NOTE: Black area denotes welded head bracket.

DF-U - Denotes muffler used primarily as Direct Fit, but is also Universal.
U-DF - Denotes muffler used primarily as Universal, but is also Direct Fit.

DF - Direct Fit Muffler
U - Universal Muffler
HS - Denotes Heat Shield is on muffler.

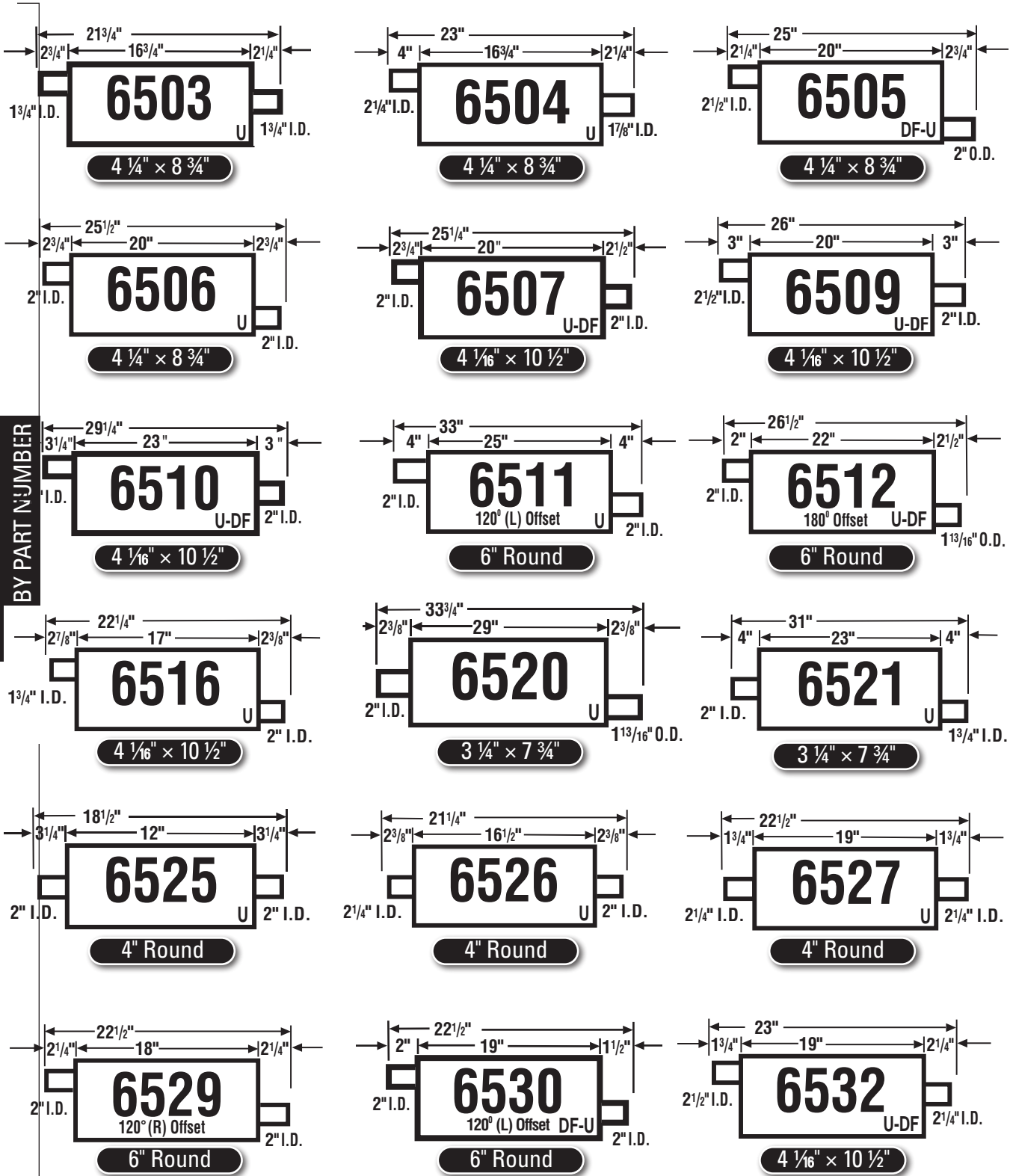

NOTE: Black area denotes welded head bracket.

DF-U - Denotes muffler used primarily as Direct Fit, but is also Universal.

U-DF - Denotes muffler used primarily as Universal, but is also Direct Fit.

DF - Direct Fit Muffler

U - Universal Muffler

HS - Denotes Heat Shield is on muffler.

MUFFLER SPECS

by PART NUMBER

MAXIMUM **TMSL**[®]

M/S L BY PART NUMBER

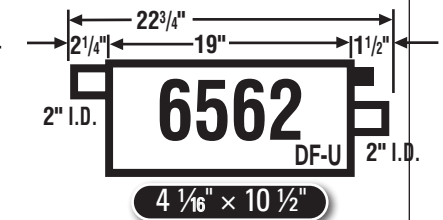
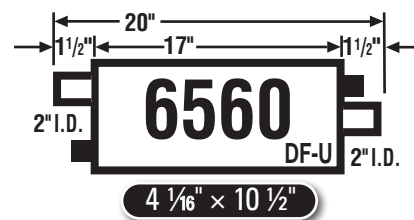
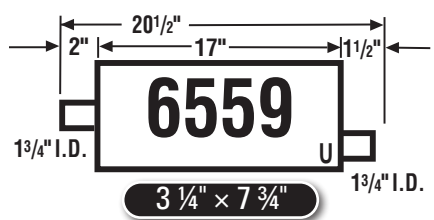
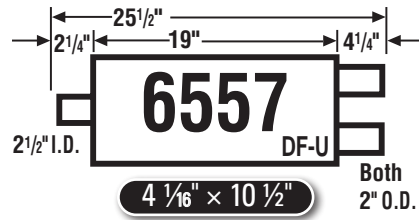
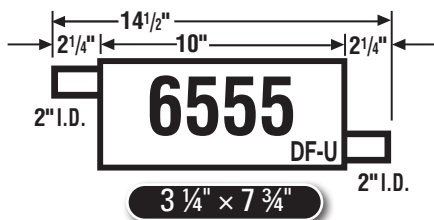
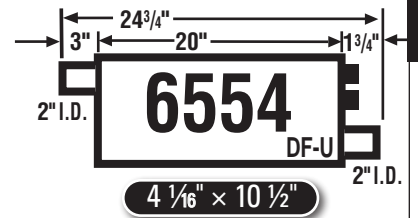
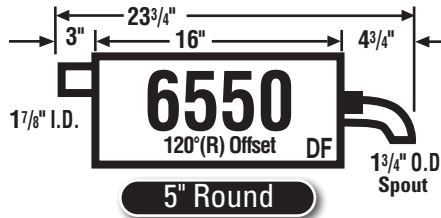
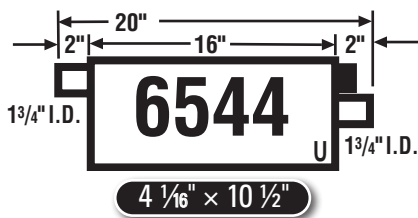
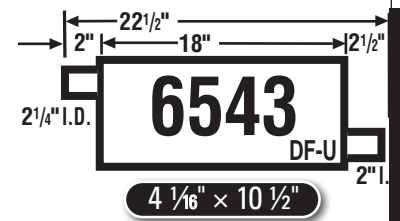
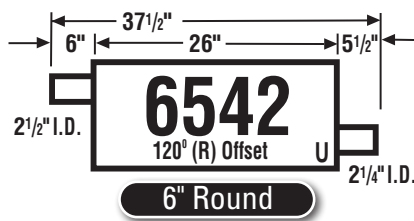
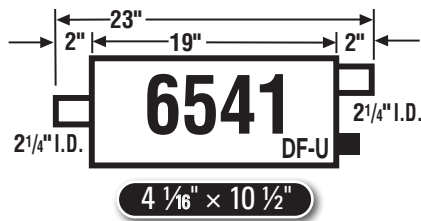
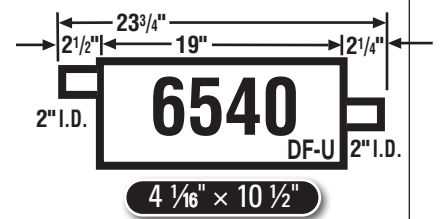
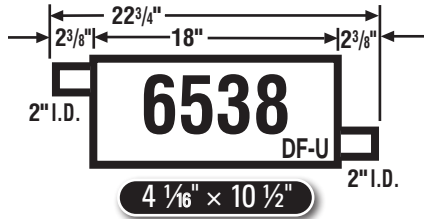
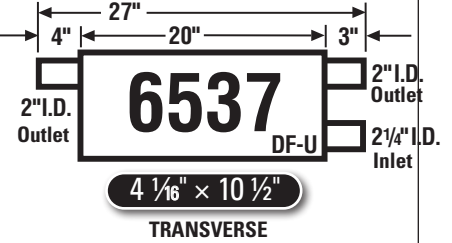
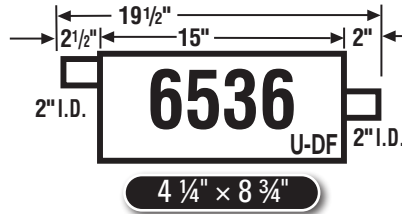
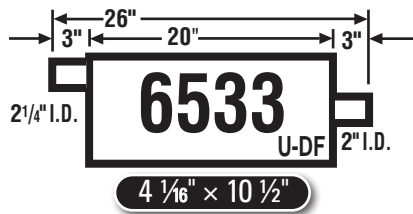

NOTE: Black area denotes welded head bracket.

DF-U - Denotes muffler used primarily as Direct Fit, but is also Universal.
U-DF - Denotes muffler used primarily as Universal, but is also Direct Fit.

DF - Direct Fit Muffler
U - Universal Muffler
HS - Denotes Heat Shield is on muffler.

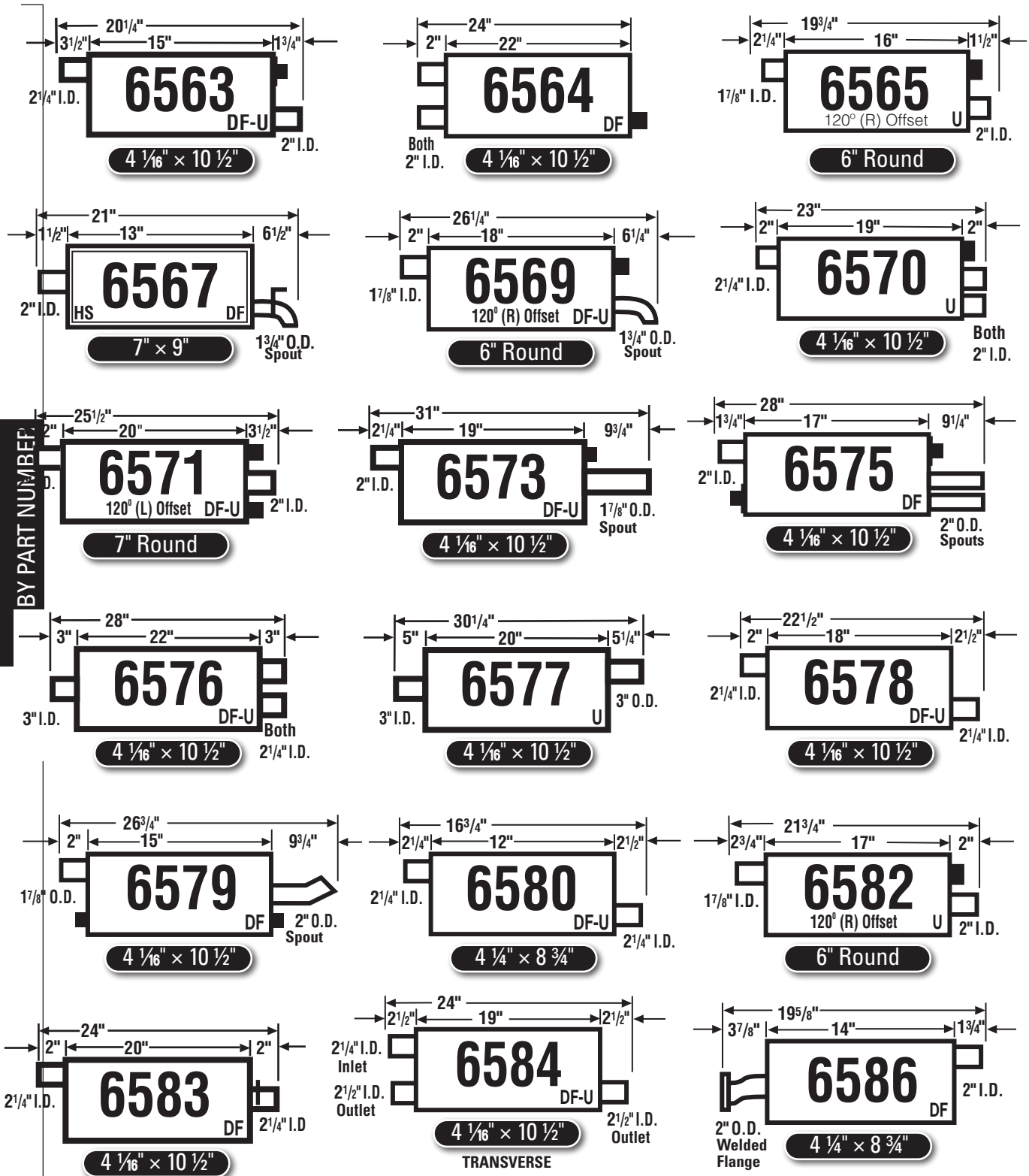

NOTE: Black area denotes welded head bracket.

DF-U - Denotes muffler used primarily as Direct Fit, but is also Universal.

U-DF - Denotes muffler used primarily as Universal, but is also Direct Fit.

DF - Direct Fit Muffler

U - Universal Muffler

HS - Denotes Heat Shield is on muffler.

MUFFLER SPECS

by PART NUMBER

MAXIMUM **TMSL**[®]

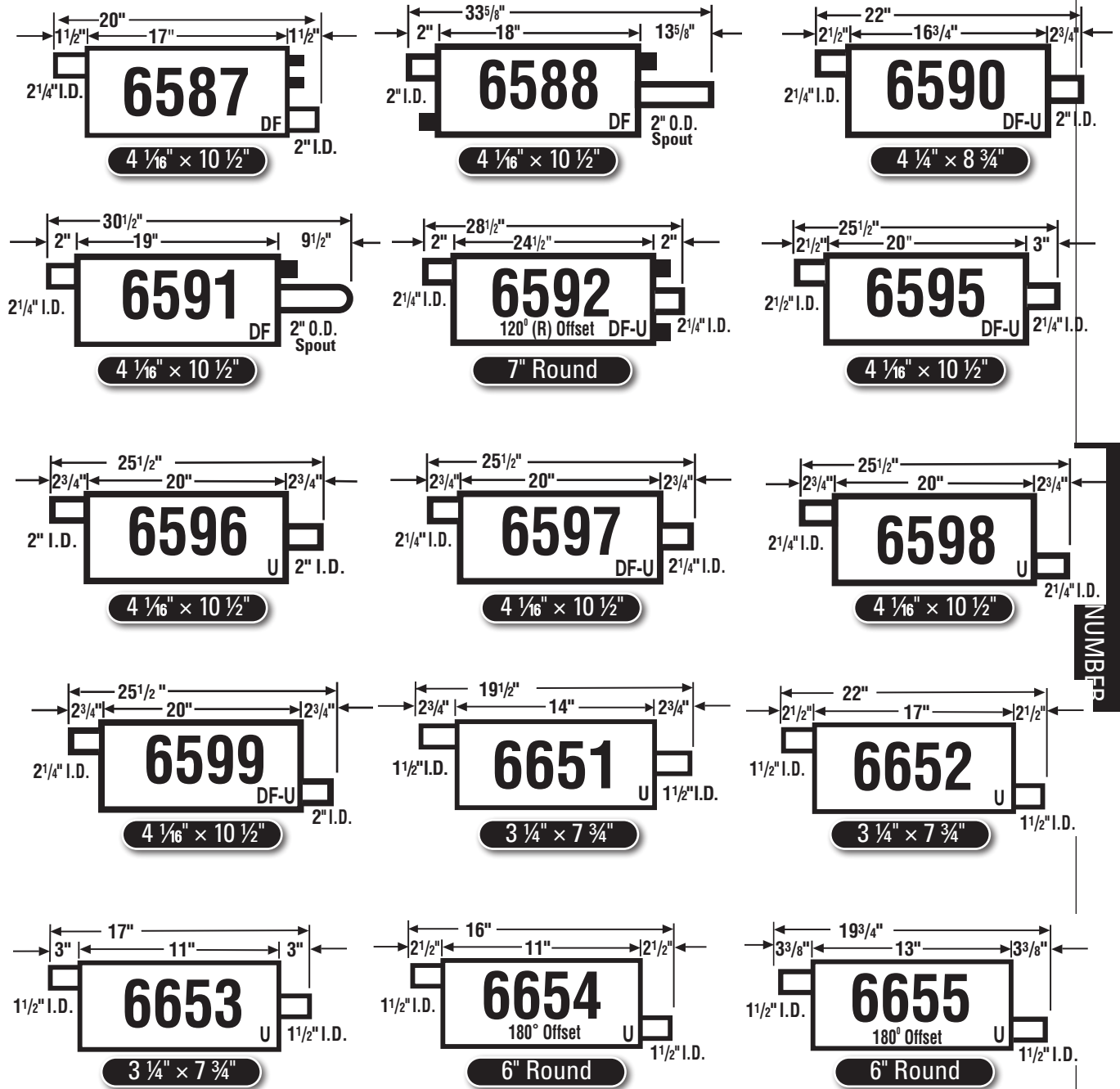

NUMBER

NOTE: Black area denotes welded head bracket.

DF-U - Denotes muffler used primarily as Direct Fit, but is also Universal.
 U-DF - Denotes muffler used primarily as Universal, but is also Direct Fit.

DF - Direct Fit Muffler
 U - Universal Muffler
 HS - Denotes Heat Shield is on muffler.

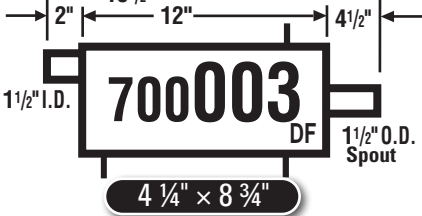
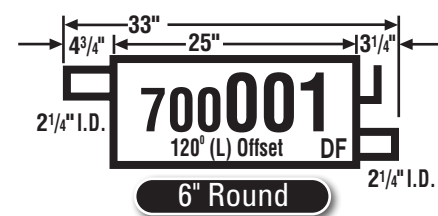
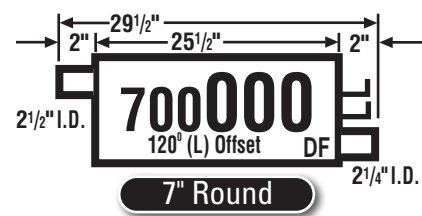
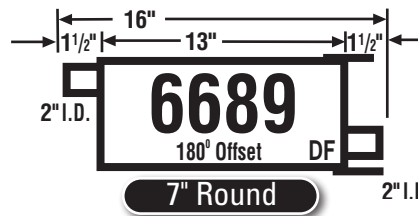
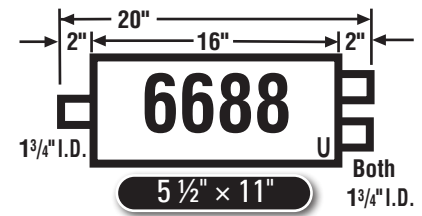
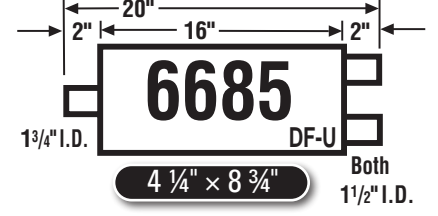
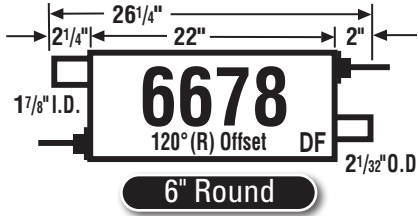
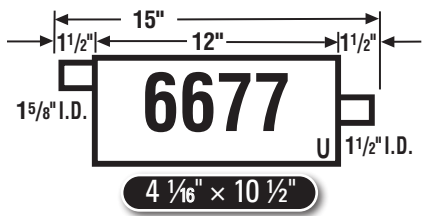
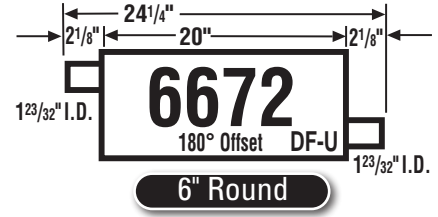
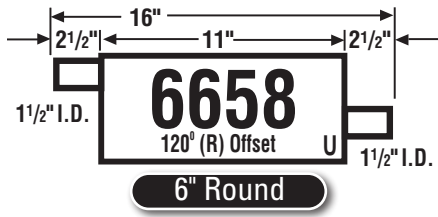

NOTE: Black area denotes welded head bracket.

DF-U - Denotes muffler used primarily as Direct Fit, but is also Universal.

U-DF - Denotes muffler used primarily as Universal, but is also Direct Fit.

DF - Direct Fit Muffler

U - Universal Muffler

HS - Denotes Heat Shield is on muffler.

MUFFLER SPECS

by PART NUMBER

MAXIMUM **MSL**[®]

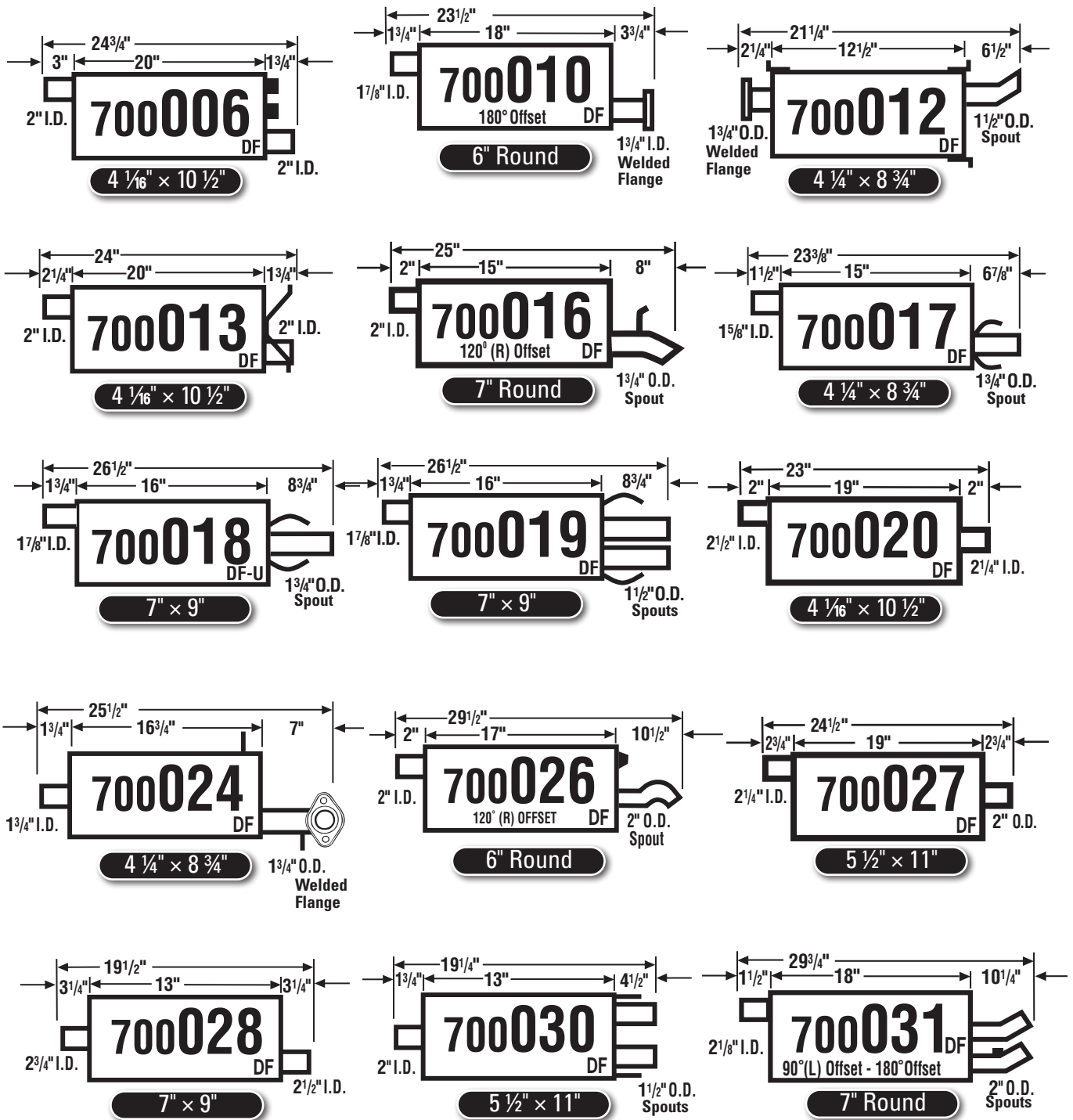

MSL BY PART NUMBER

NOTE: Black area denotes welded head bracket.

DF-U - Denotes muffler used primarily as Direct Fit, but is also Universal.

U-DF - Denotes muffler used primarily as Universal, but is also Direct Fit.

DF - Direct Fit Muffler

U - Universal Muffler

HS - Denotes Heat Shield is on muffler.

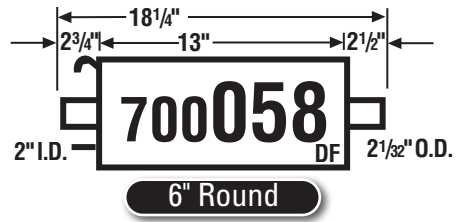
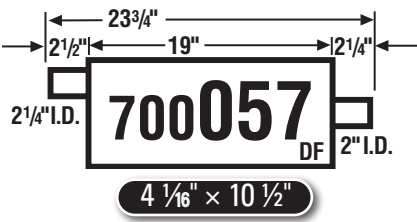
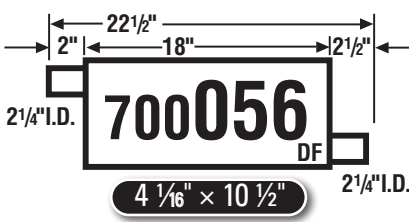
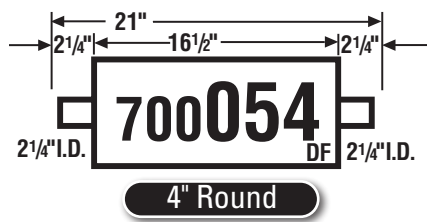
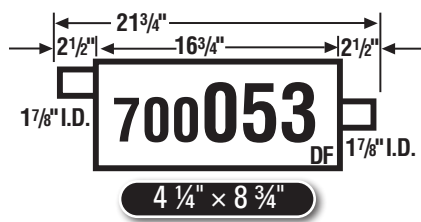
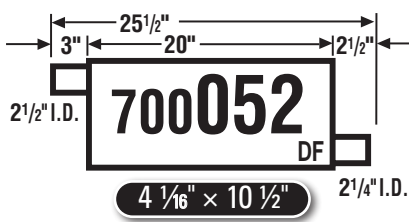
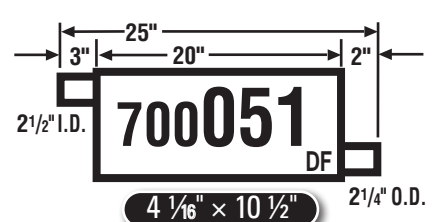
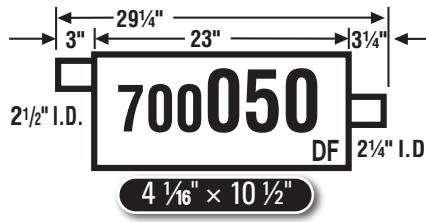
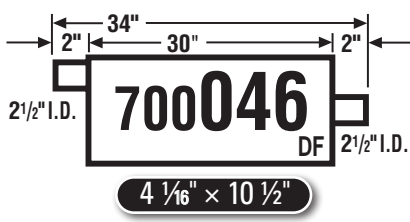
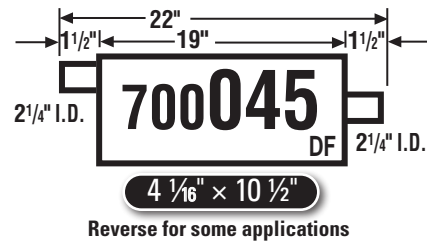
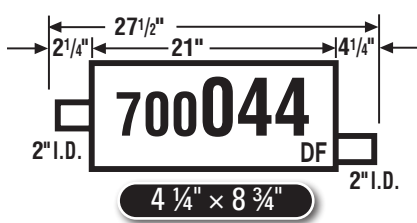
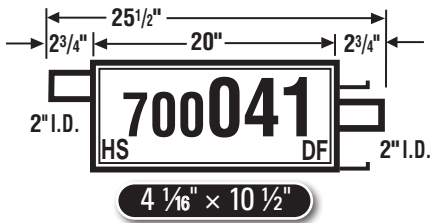
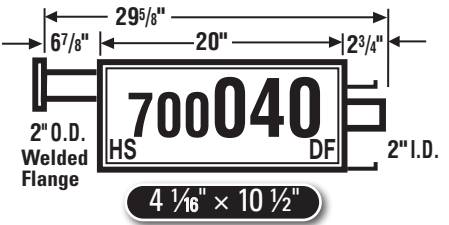
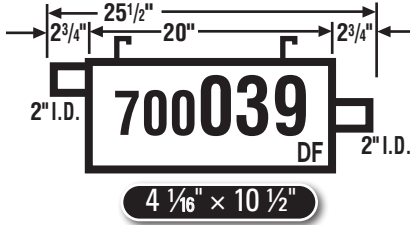
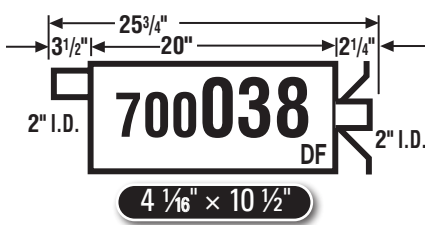
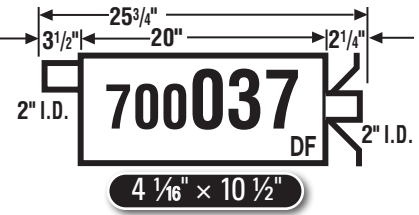
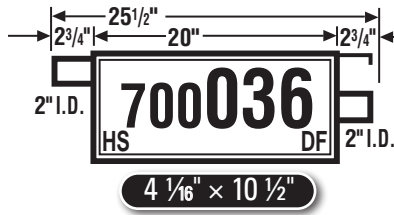
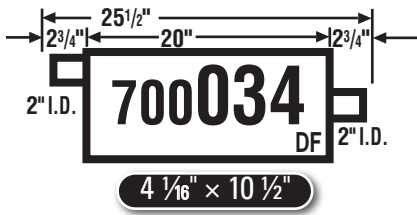

NOTE: Black area denotes welded head bracket.

DF-U - Denotes muffler used primarily as Direct Fit, but is also Universal.

U-DF - Denotes muffler used primarily as Universal, but is also Direct Fit.

DF - Direct Fit Muffler

U - Universal Muffler

HS - Denotes Heat Shield is on muffler.

MUFFLER SPECS

by PART NUMBER

MAXIMUM **TMSL**[®]

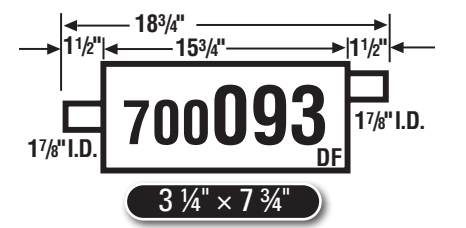
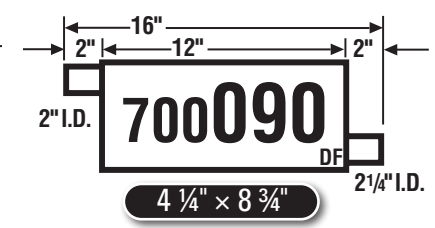
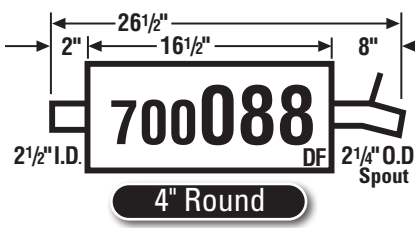
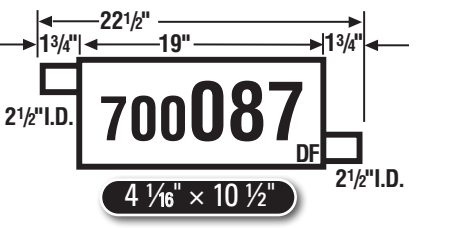
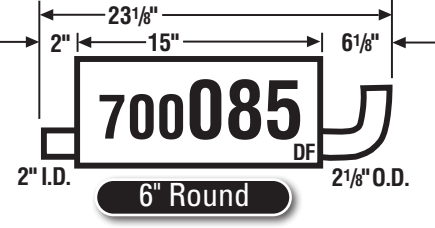
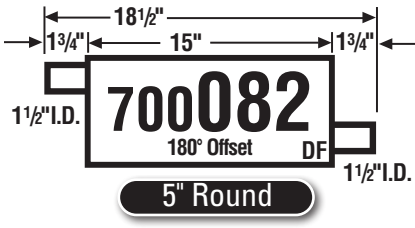
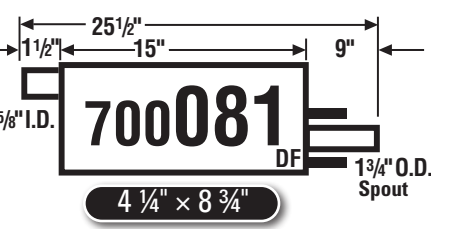
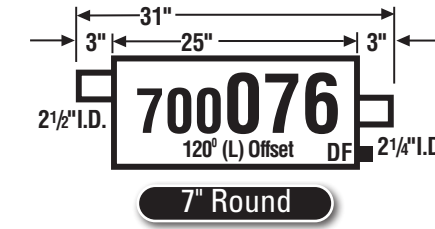
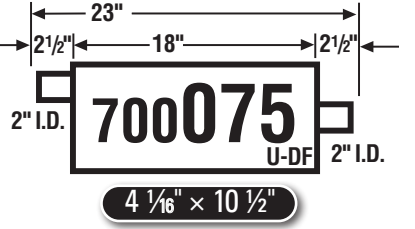
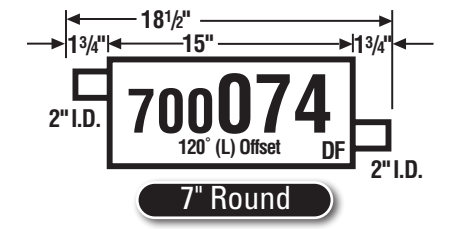
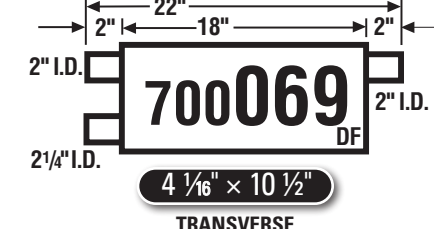
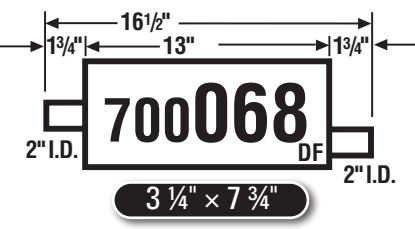
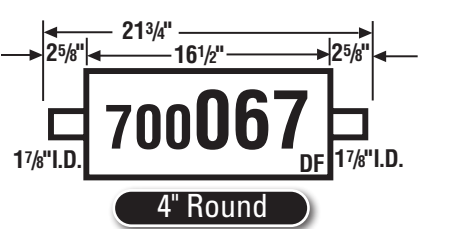
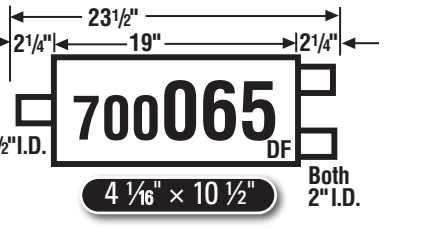
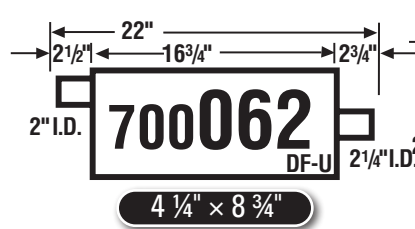
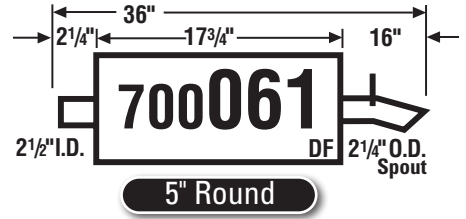
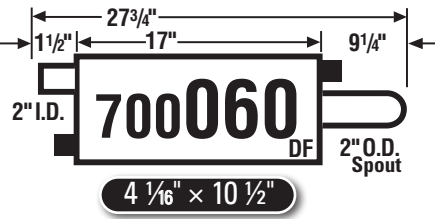
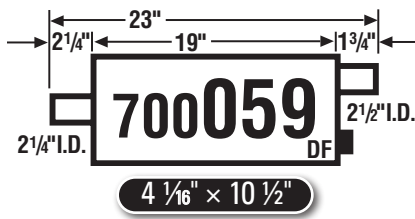

MSL BY PART NUMBER

NOTE: Black area denotes welded head bracket.

DF-U - Denotes muffler used primarily as Direct Fit, but is also Universal.
U-DF - Denotes muffler used primarily as Universal, but is also Direct Fit.

DF - Direct Fit Muffler
U - Universal Muffler
HS - Denotes Heat Shield is on muffler.

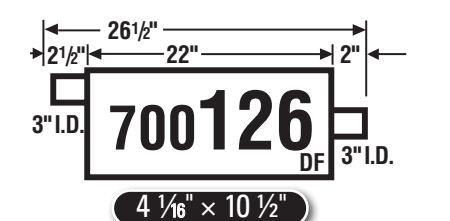
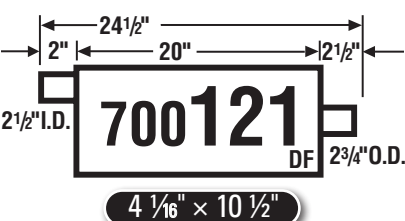
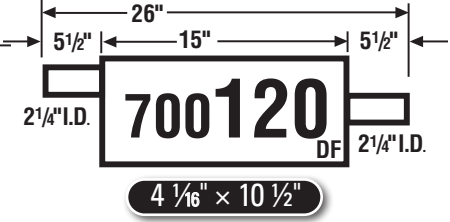
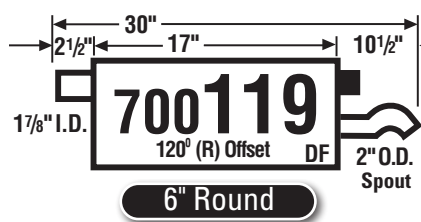
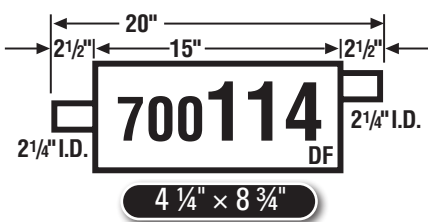
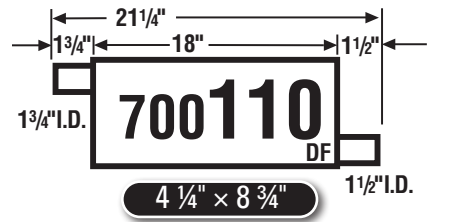
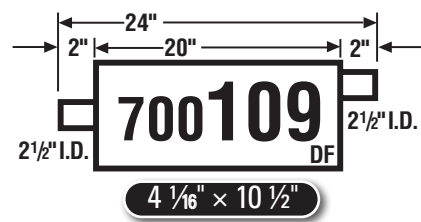
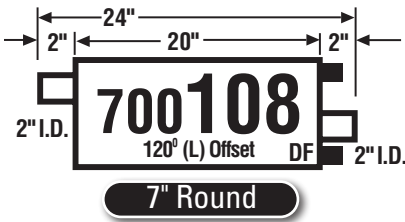
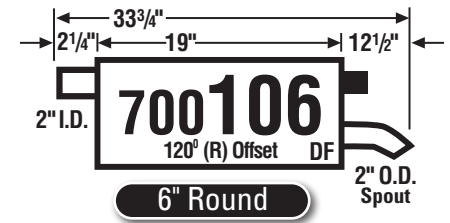
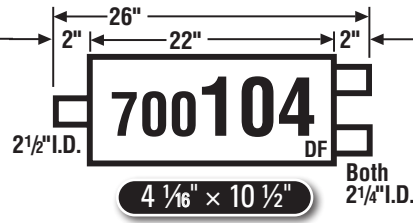
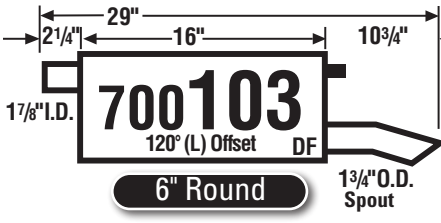
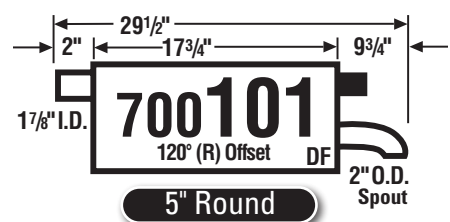
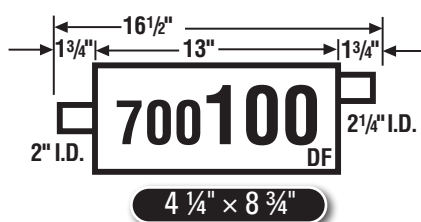
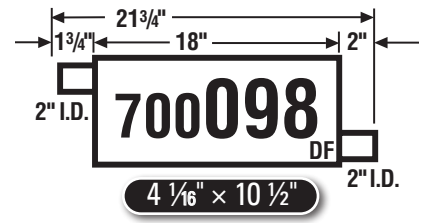
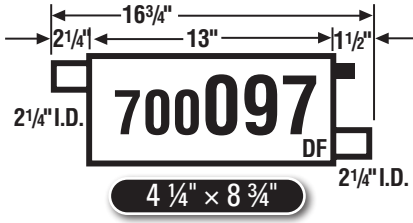
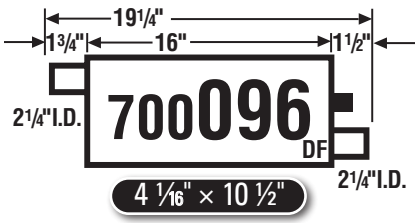

NOTE: Black area denotes welded head bracket.

DF-U - Denotes muffler used primarily as Direct Fit, but is also Universal.

U-DF - Denotes muffler used primarily as Universal, but is also Direct Fit.

DF - Direct Fit Muffler

U - Universal Muffler

HS - Denotes Heat Shield is on muffler.

MUFFLER SPECS

by PART NUMBER

MAXIMUM **TMSL**[®]

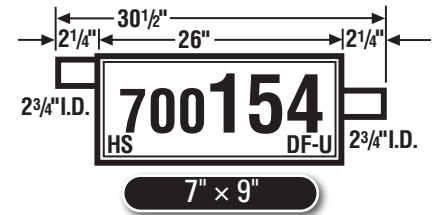
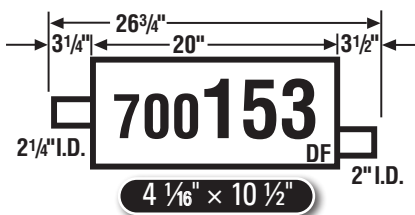
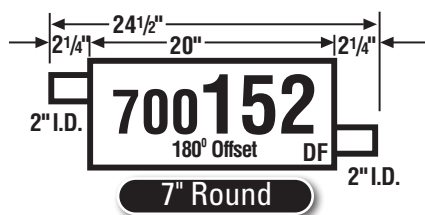
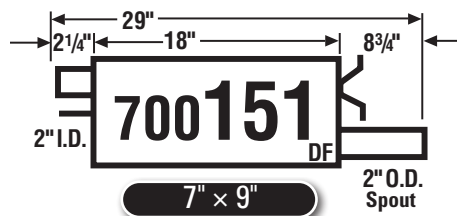
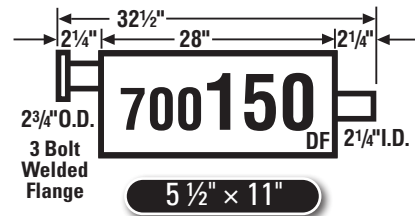
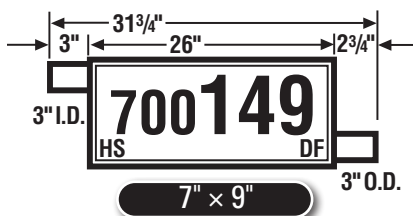
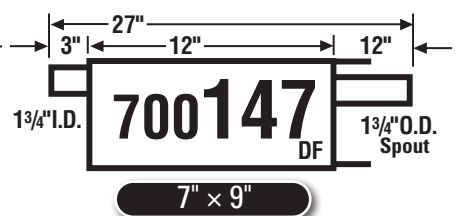
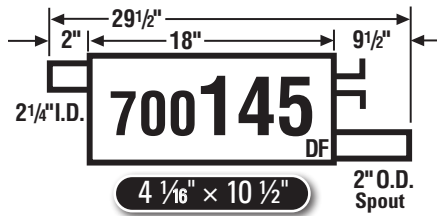
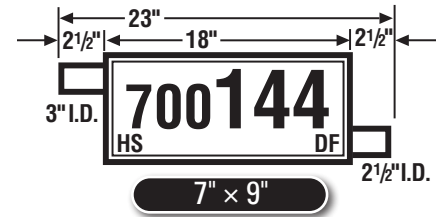
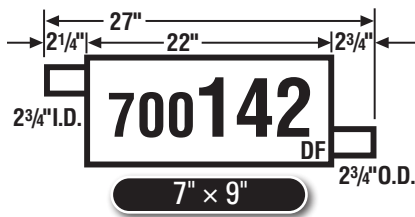
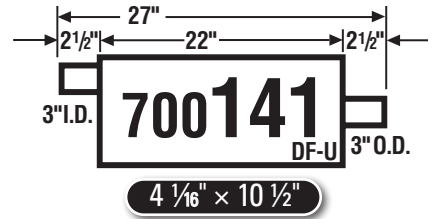
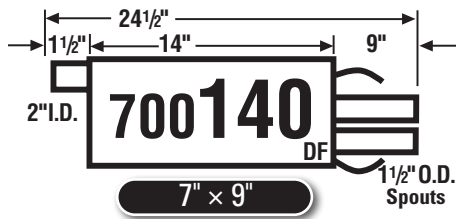
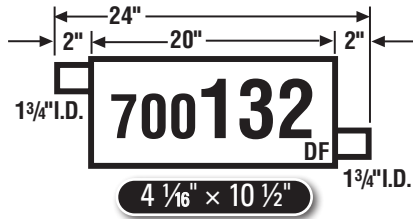
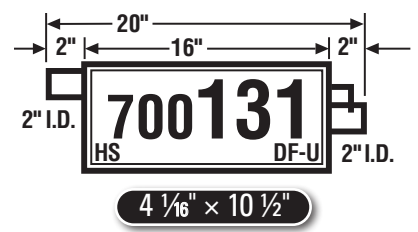
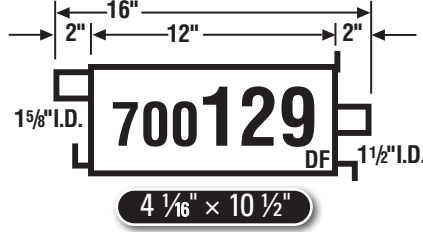
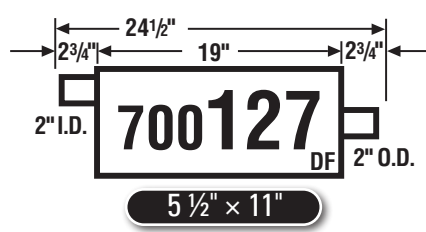

MSL BY PART NUMBER

NOTE: Black area denotes welded head bracket.

DF-U - Denotes muffler used primarily as Direct Fit, but is also Universal.
 U-DF - Denotes muffler used primarily as Universal, but is also Direct Fit.

DF - Direct Fit Muffler
 U - Universal Muffler
 HS - Denotes Heat Shield is on muffler.

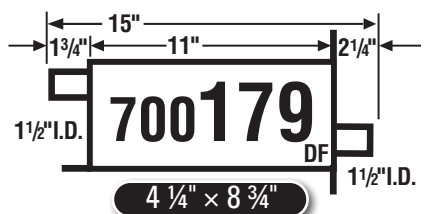
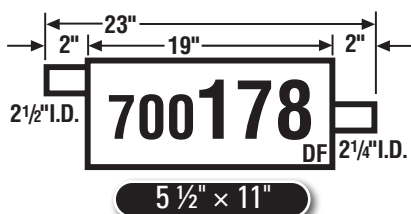
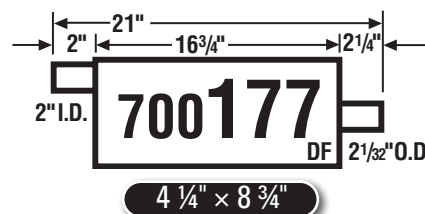
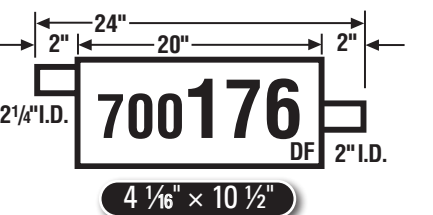
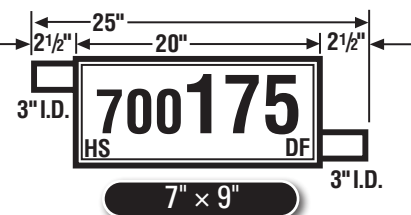
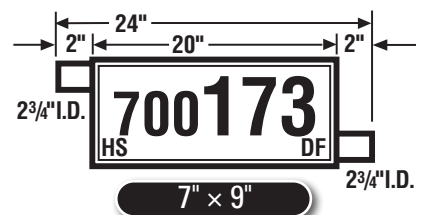
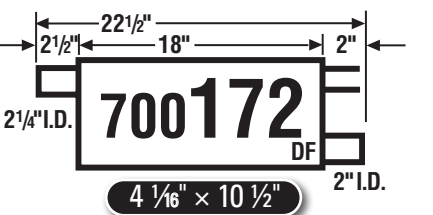
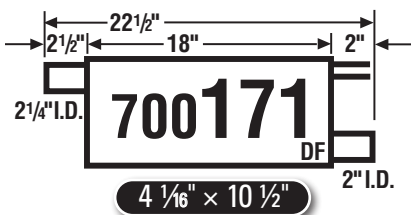
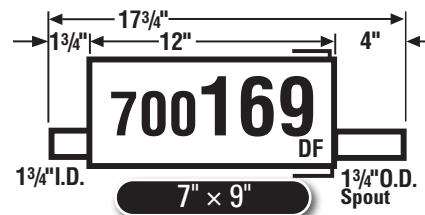
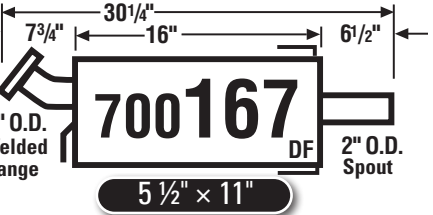
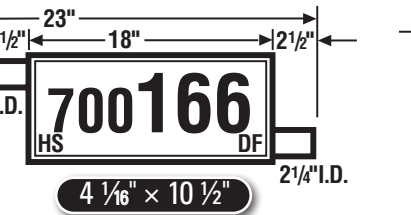
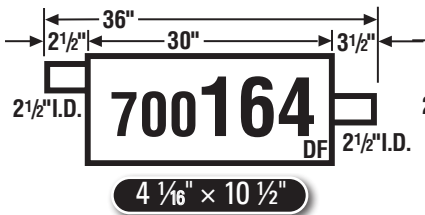
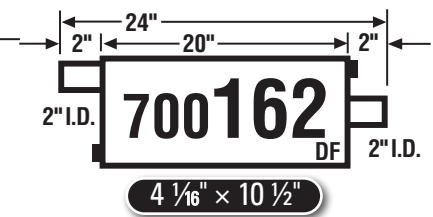
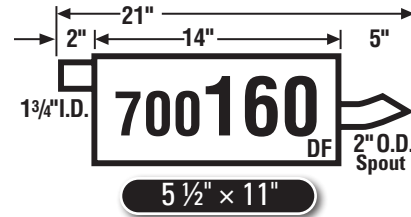
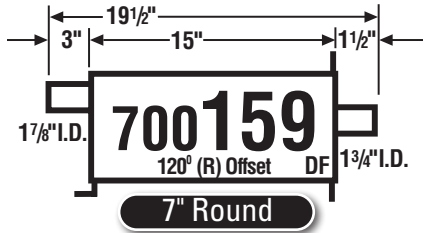
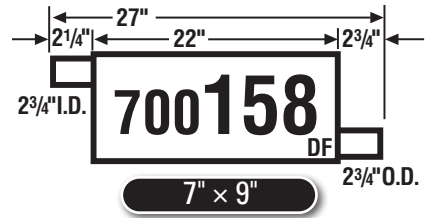
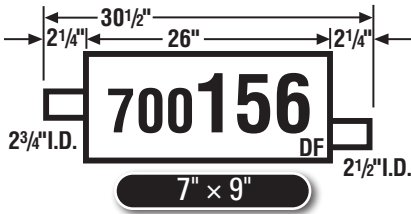
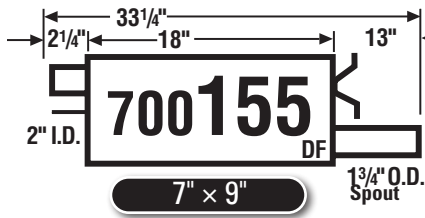

NOTE: Black area denotes welded head bracket.

DF-U - Denotes muffler used primarily as Direct Fit, but is also Universal.

U-DF - Denotes muffler used primarily as Universal, but is also Direct Fit.

DF - Direct Fit Muffler

U - Universal Muffler

HS - Denotes Heat Shield is on muffler.

MUFFLER SPECS

by PART NUMBER

MAXIMUM **TMSL**

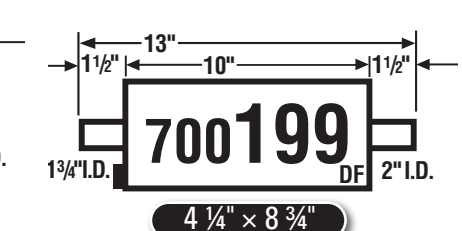
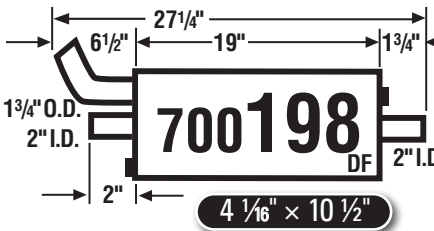
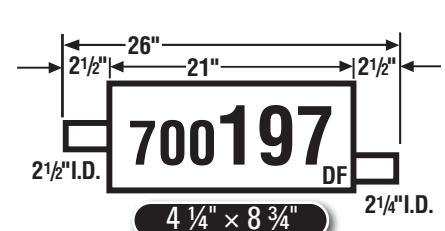
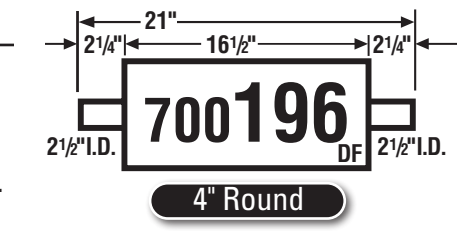
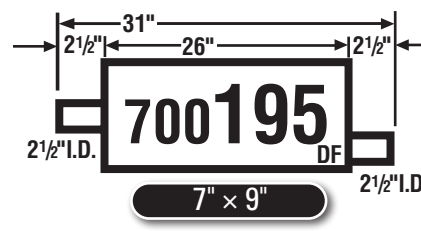
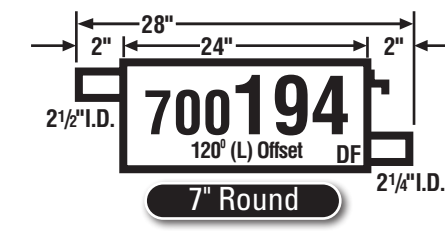
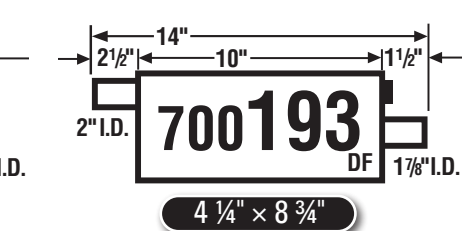
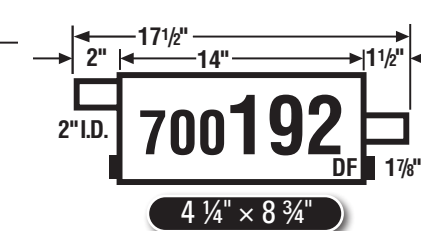
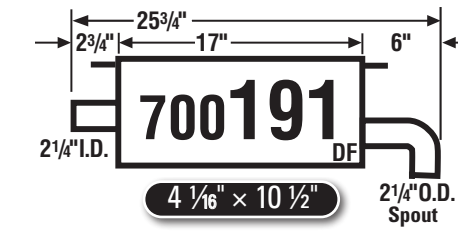
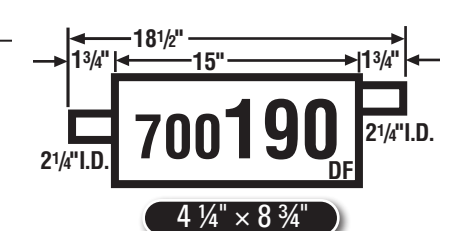
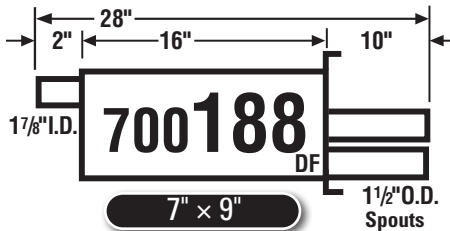
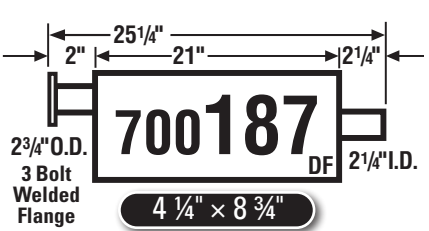
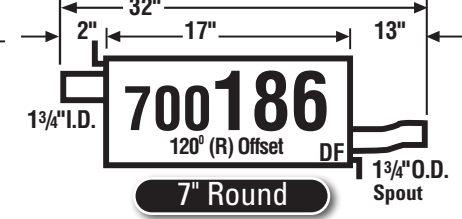
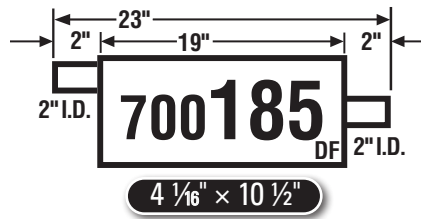
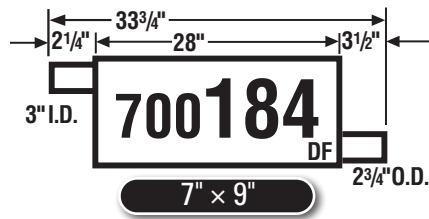
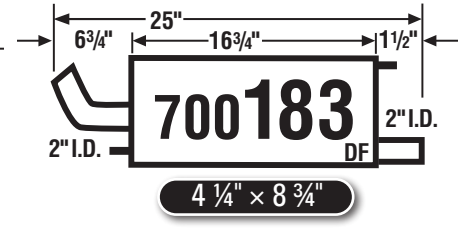
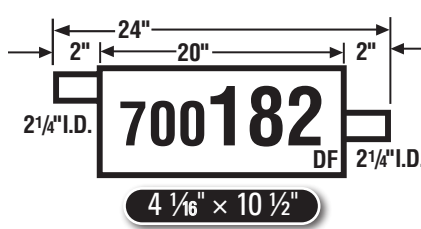
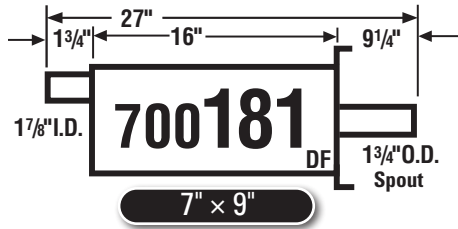

MSL BY PART NUMBER

NOTE: Black area denotes welded head bracket.

DF-U - Denotes muffler used primarily as Direct Fit, but is also Universal.
 U-DF - Denotes muffler used primarily as Universal, but is also Direct Fit.

DF - Direct Fit Muffler
 U - Universal Muffler
 HS - Denotes Heat Shield is on muffler.

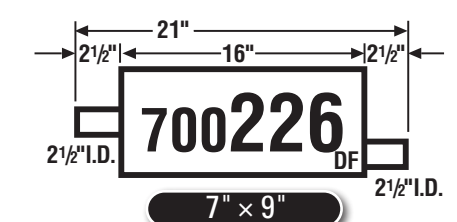
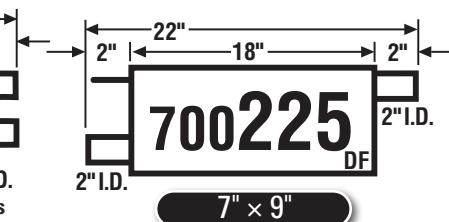
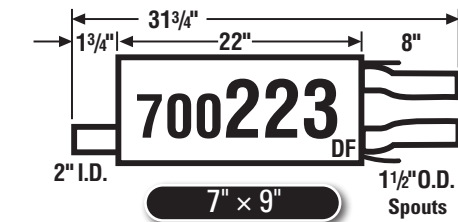
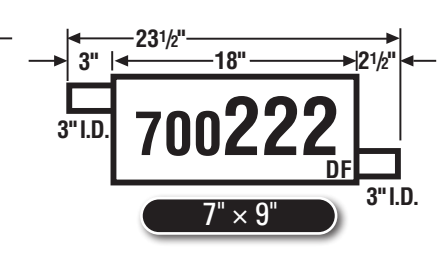
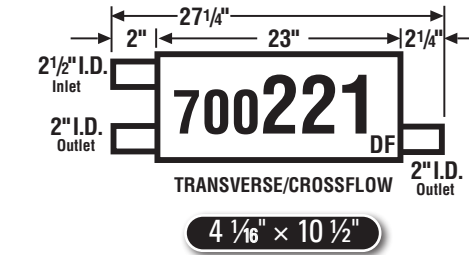
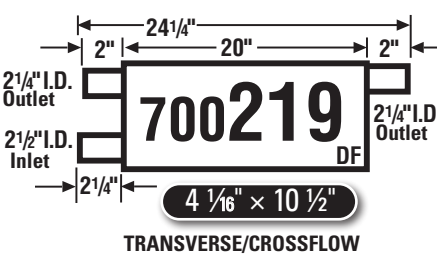
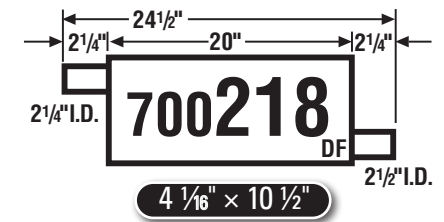
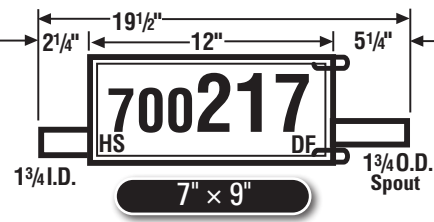
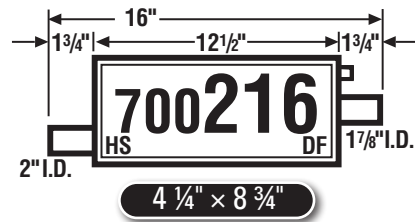
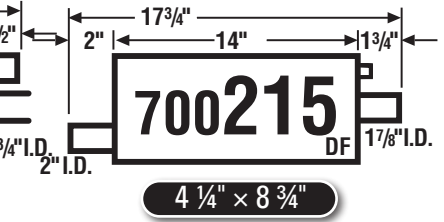
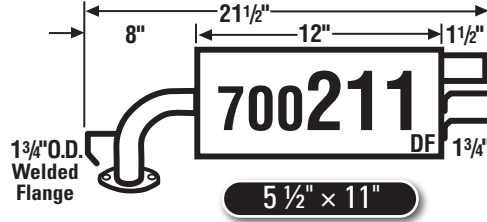
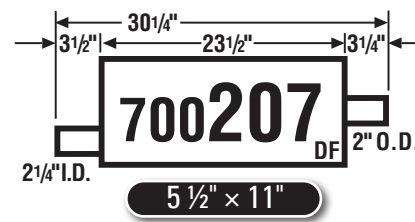
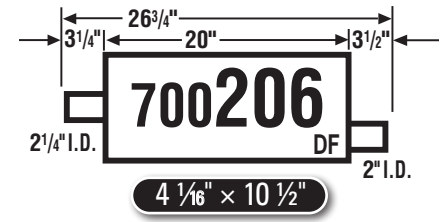
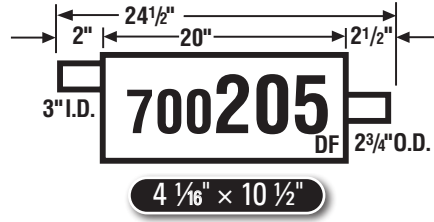
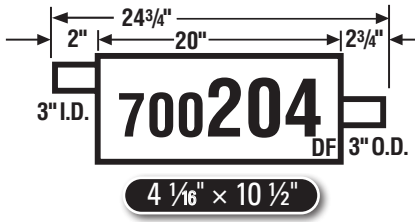
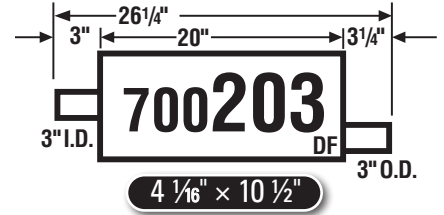
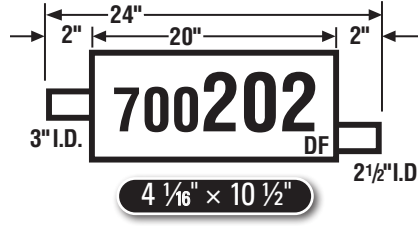
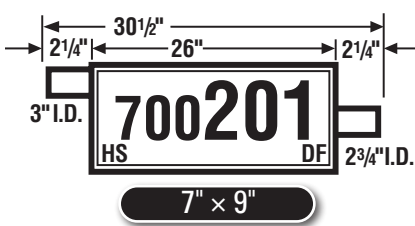

NOTE: Black area denotes welded head bracket.

DF-U - Denotes muffler used primarily as Direct Fit, but is also Universal.

U-DF - Denotes muffler used primarily as Universal, but is also Direct Fit.

DF - Direct Fit Muffler

U - Universal Muffler

HS - Denotes Heat Shield is on muffler.

MUFFLER SPECS

by PART NUMBER

MAXIMUM **TMSL**[®]

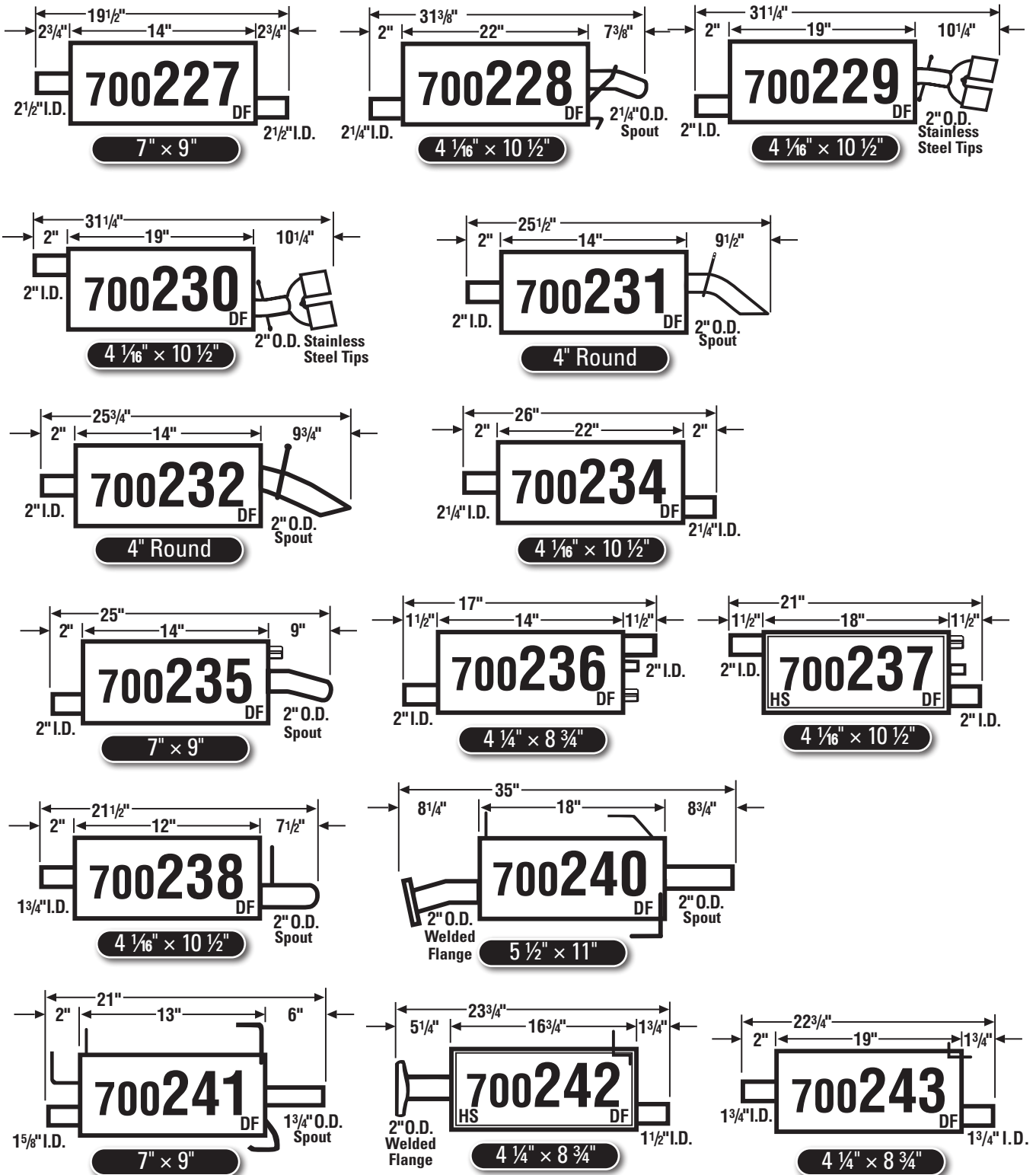

MSL BY PART NUMBER

NOTE: Black area denotes welded head bracket.

DF-U - Denotes muffler used primarily as Direct Fit, but is also Universal.
 U-DF - Denotes muffler used primarily as Universal, but is also Direct Fit.

DF - Direct Fit Muffler
 U - Universal Muffler
 HS - Denotes Heat Shield is on muffler.

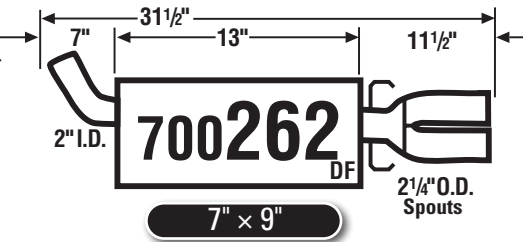
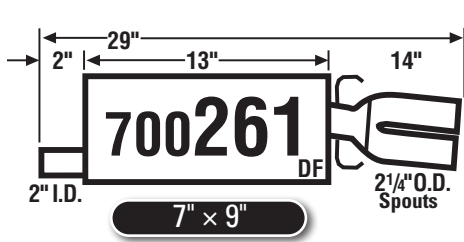
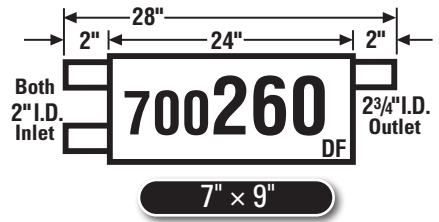
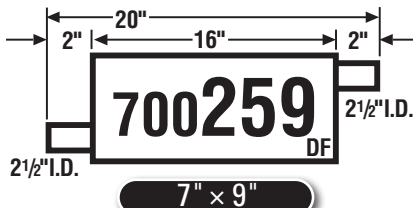
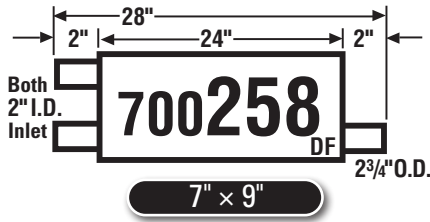
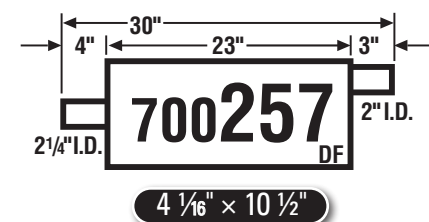
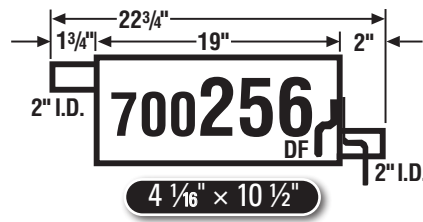
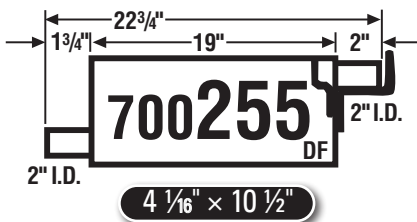
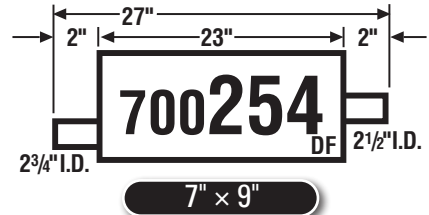
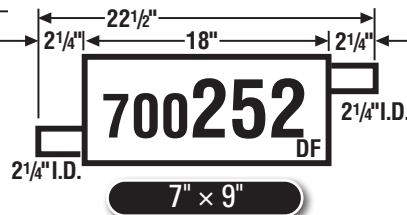
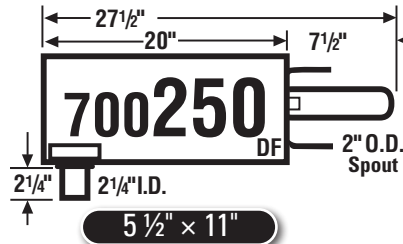
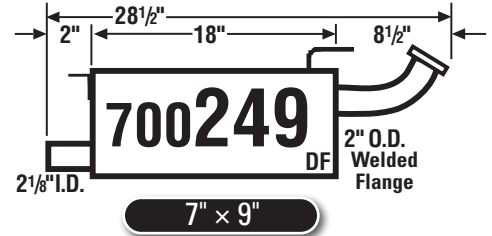
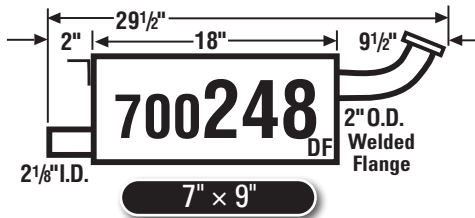
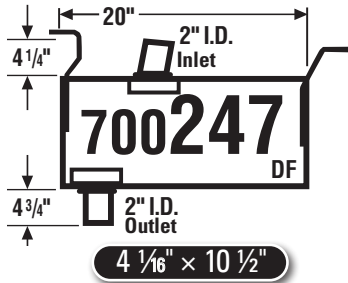
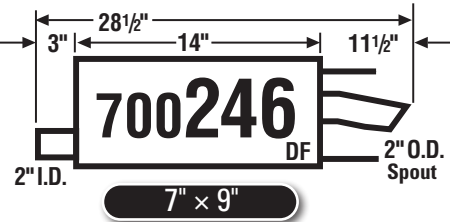
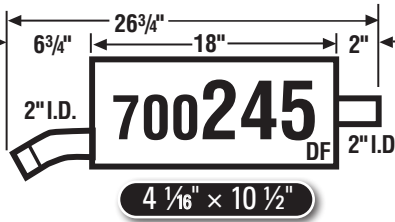
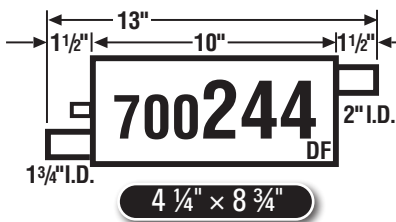

NOTE: Black area denotes welded head bracket.

DF-U - Denotes muffler used primarily as Direct Fit, but is also Universal.

U-DF - Denotes muffler used primarily as Universal, but is also Direct Fit.

DF - Direct Fit Muffler

U - Universal Muffler

HS - Denotes Heat Shield is on muffler.

MUFFLER SPECS

by PART NUMBER

MAXIMUM **TMSL**

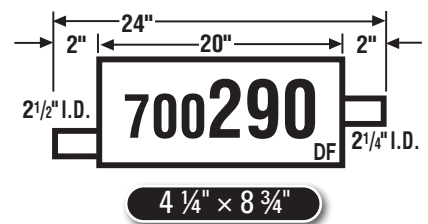
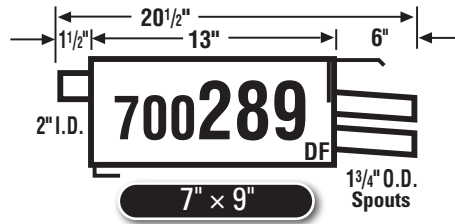
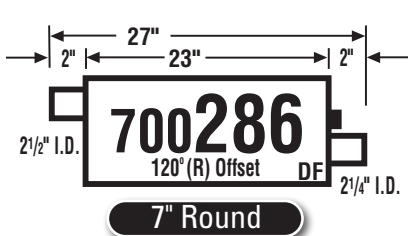
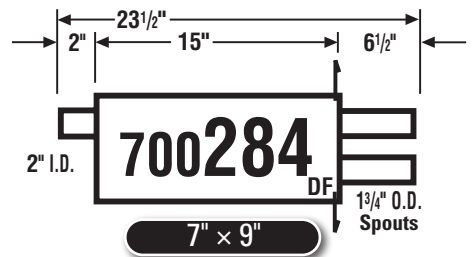
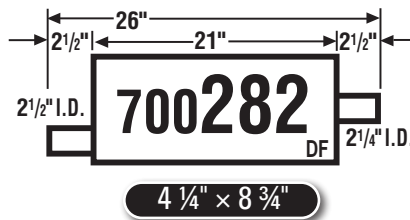
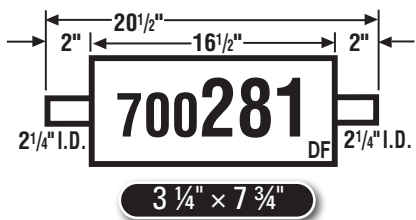
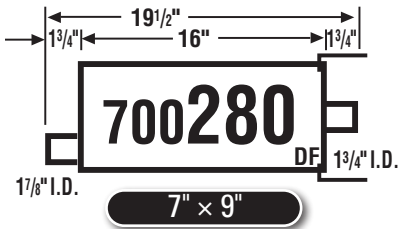
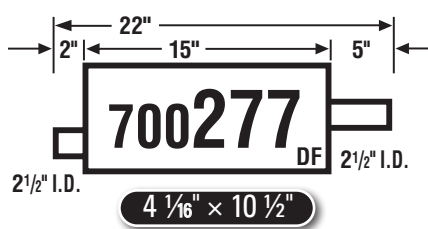
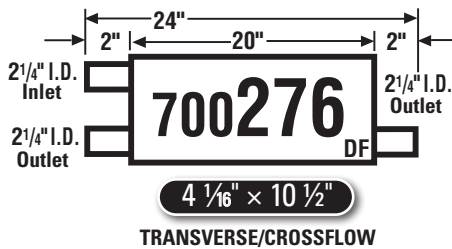
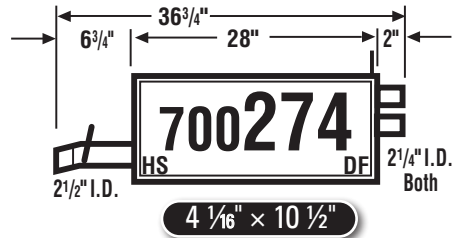
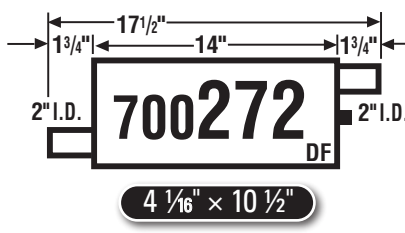
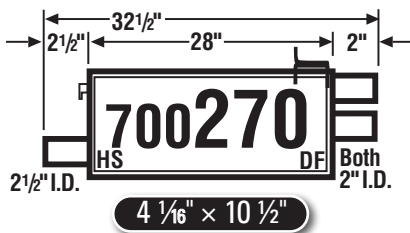
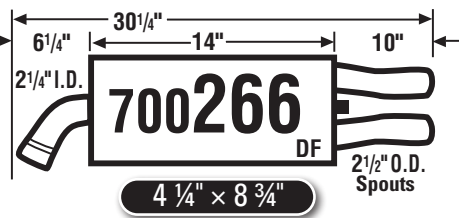
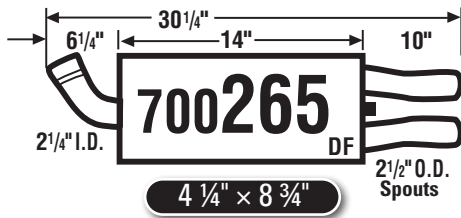
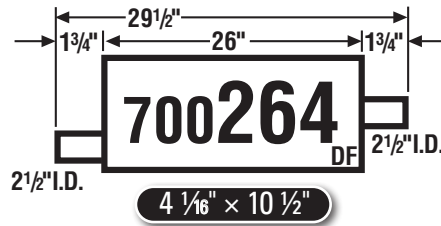
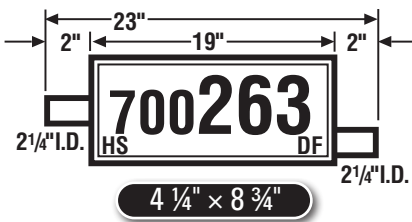

MSL BY PART NUMBER

NOTE: Black area denotes welded head bracket.

DF-U - Denotes muffler used primarily as Direct Fit, but is also Universal.
 U-DF - Denotes muffler used primarily as Universal, but is also Direct Fit.

DF - Direct Fit Muffler
 U - Universal Muffler
 HS - Denotes Heat Shield is on muffler.

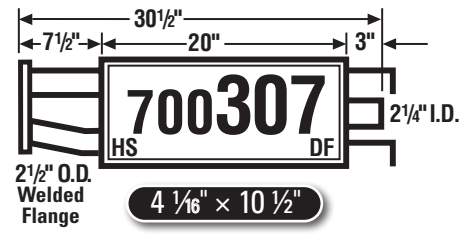
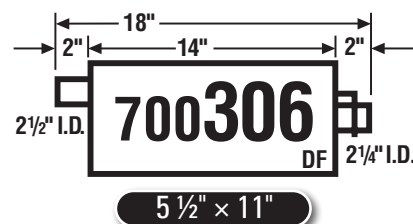
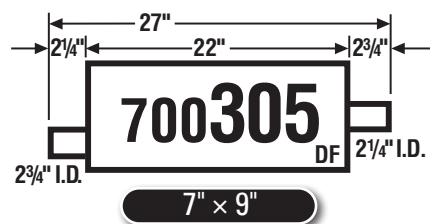
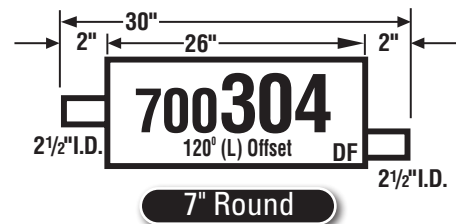
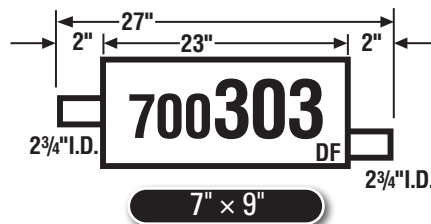
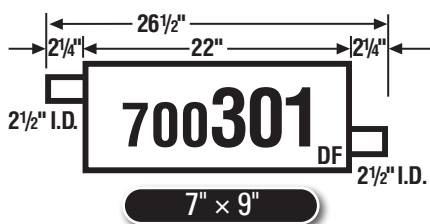
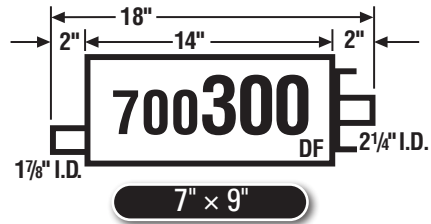
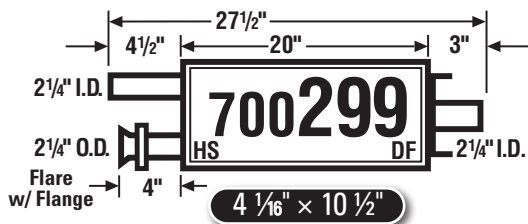
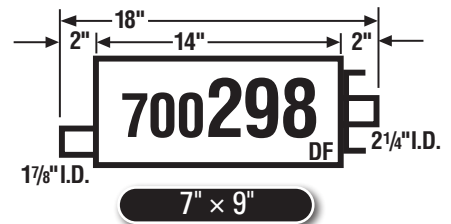
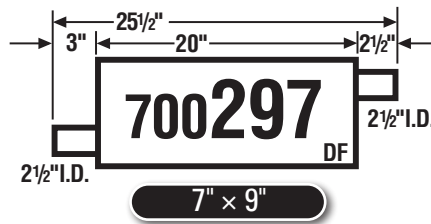
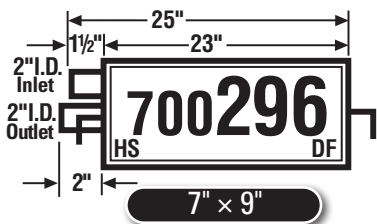
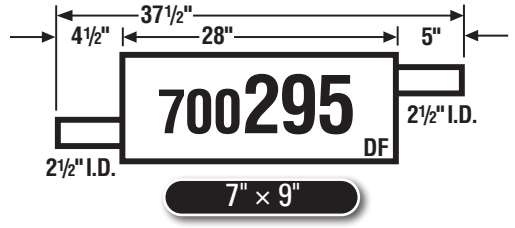
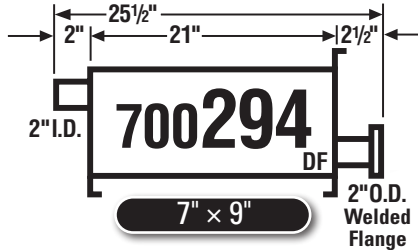
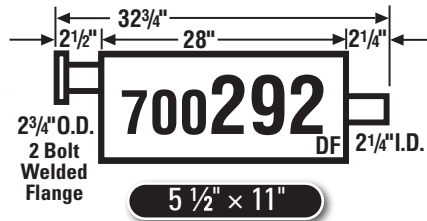
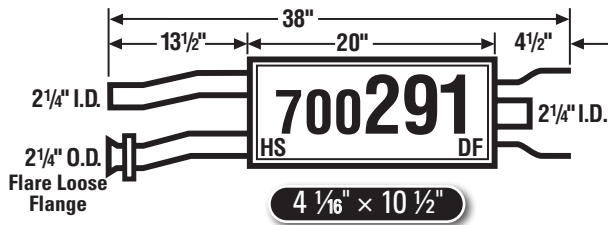

NOTE: Black area denotes welded head bracket.

DF-U - Denotes muffler used primarily as Direct Fit, but is also Universal.

U-DF - Denotes muffler used primarily as Universal, but is also Direct Fit.

DF - Direct Fit Muffler
U - Universal Muffler

HS - Denotes Heat Shield is on muffler.

MUFFLER SPECS

by PART NUMBER

MAXIMUM **TMSL**

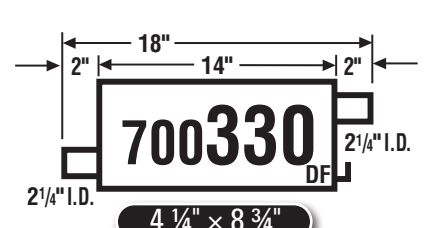
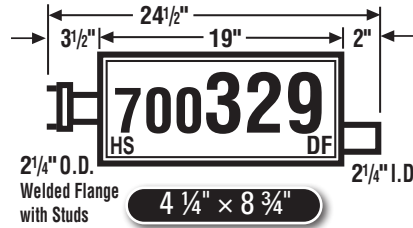
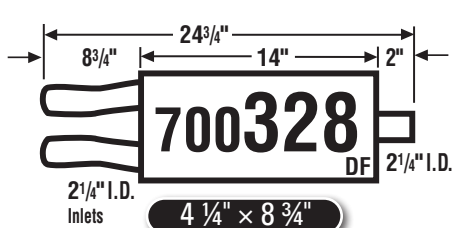
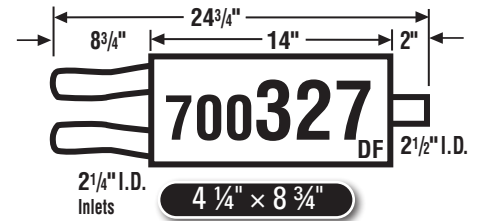
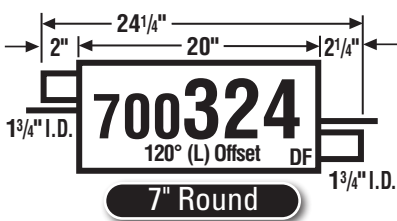
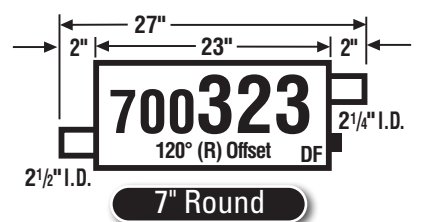
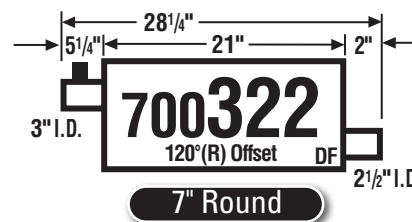
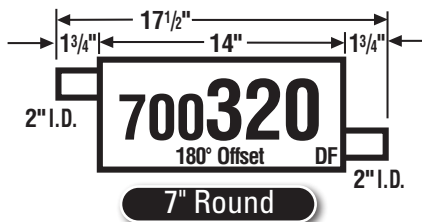
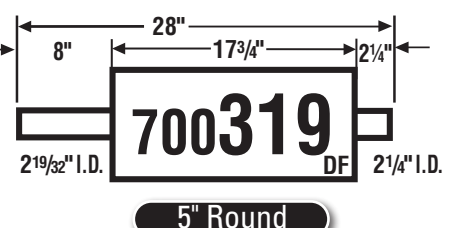
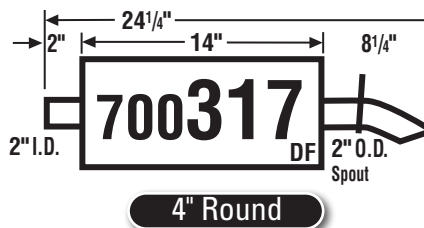
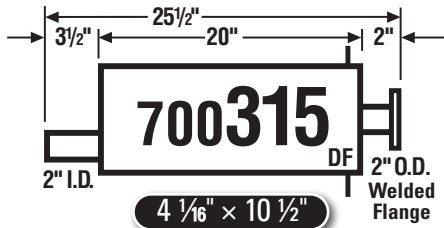
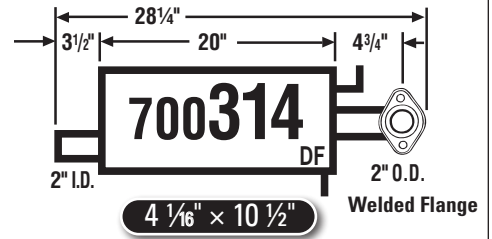
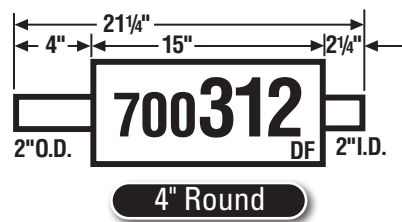
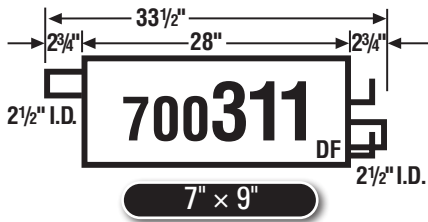
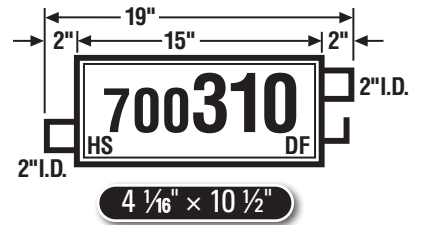
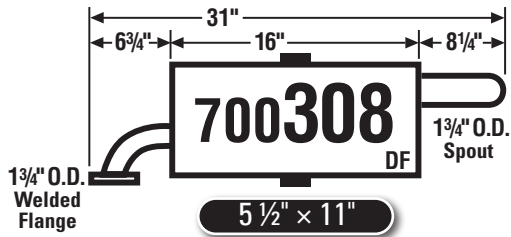

MSL BY PART NUMBER

NOTE: Black area denotes welded head bracket.

DF-U - Denotes muffler used primarily as Direct Fit, but is also Universal.

U-DF - Denotes muffler used primarily as Universal, but is also Direct Fit.

DF - Direct Fit Muffler

U - Universal Muffler

HS - Denotes Heat Shield is on muffler.

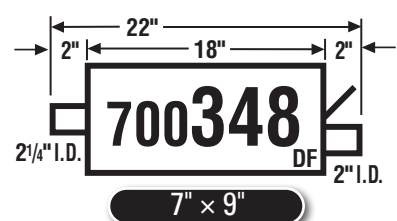
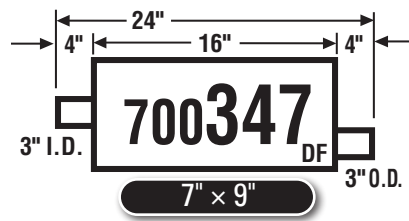
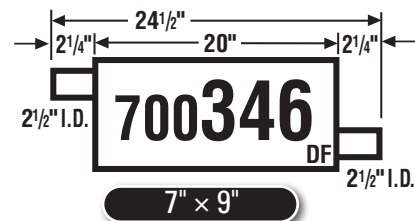
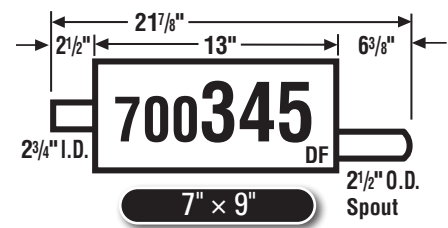
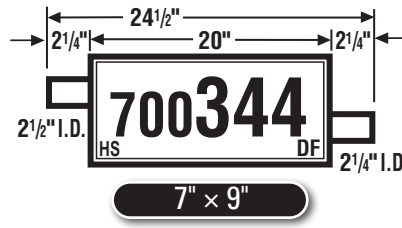
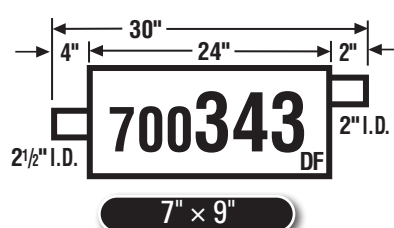
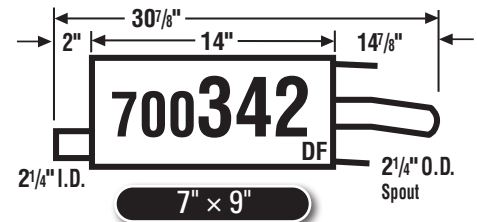
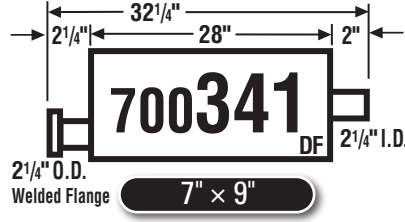
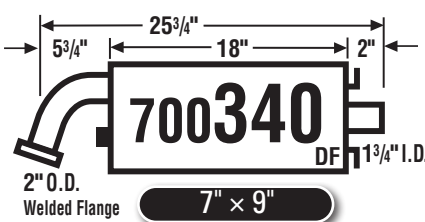
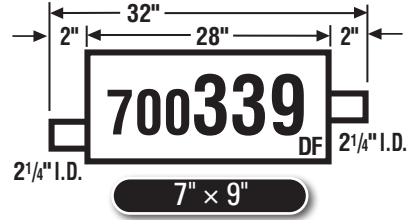
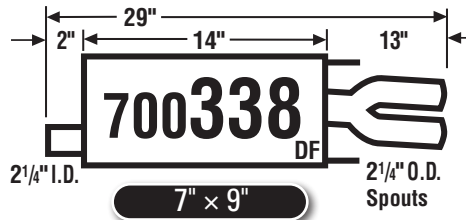
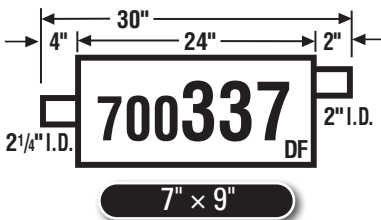
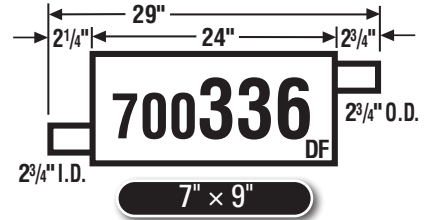
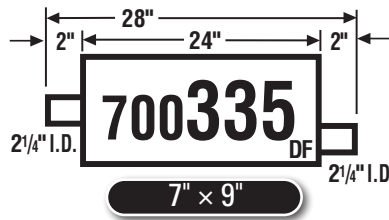
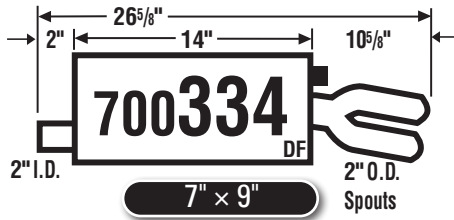
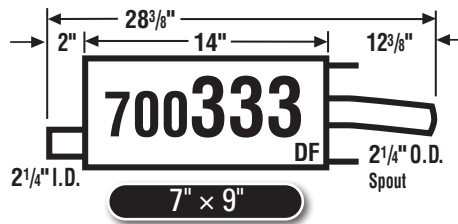
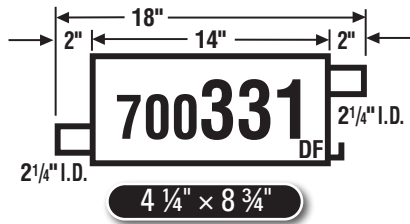

NOTE: Black area denotes welded head bracket.

DF-U - Denotes muffler used primarily as Direct Fit, but is also Universal.

U-DF - Denotes muffler used primarily as Universal, but is also Direct Fit.

DF - Direct Fit Muffler

U - Universal Muffler

HS - Denotes Heat Shield is on muffler.

MUFFLER SPECS

by PART NUMBER

MAXIMUM **MSL**

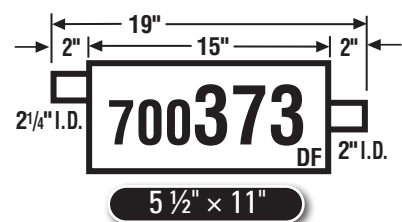
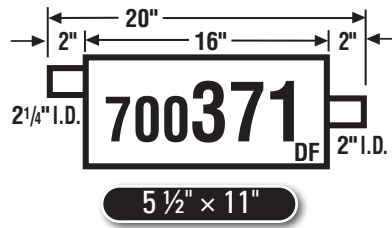
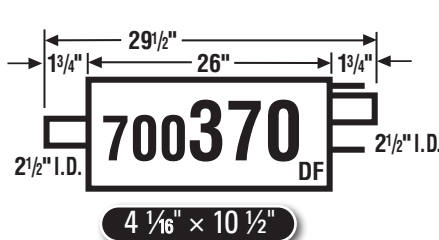
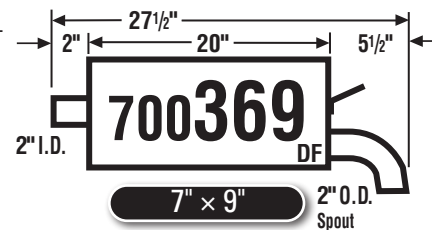
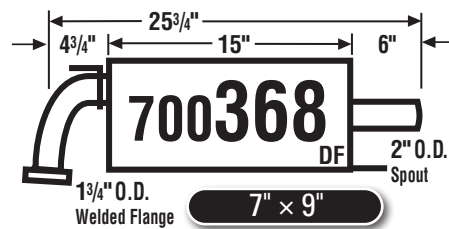
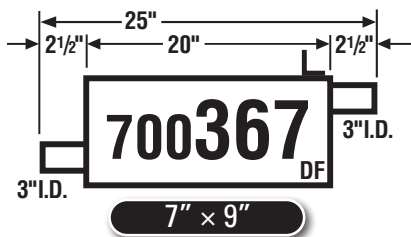
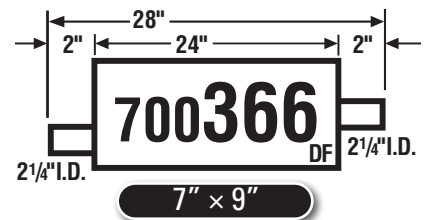
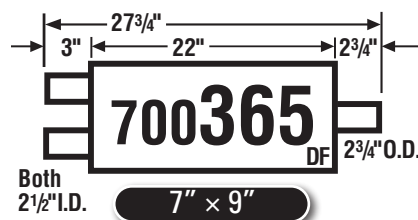
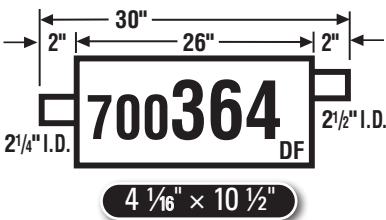
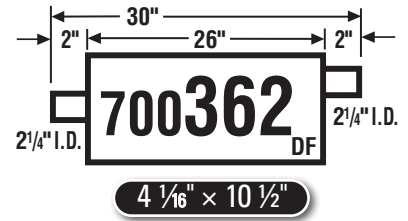
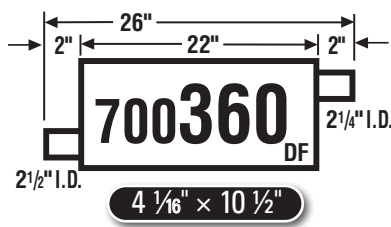
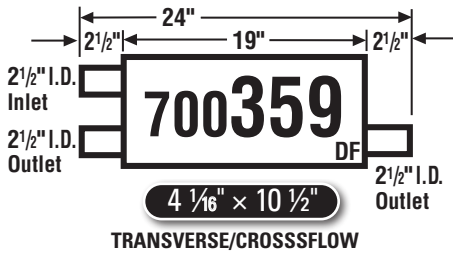
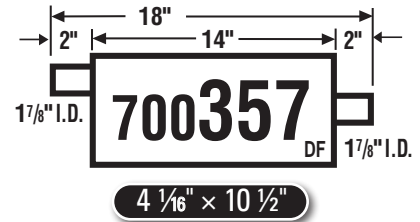
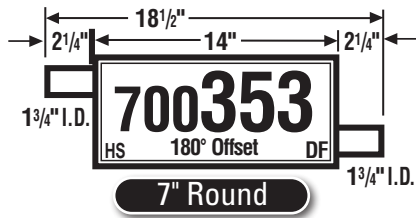
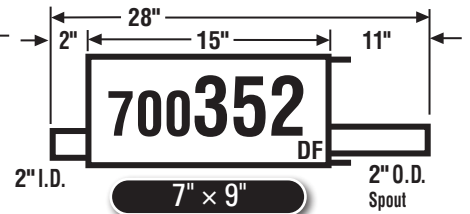
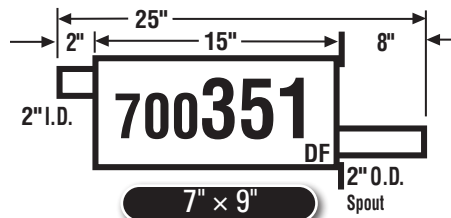
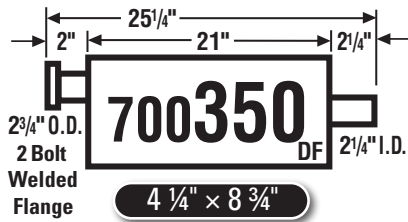

NOTE: Black area denotes welded head bracket.

DF-U - Denotes muffler used primarily as Direct Fit, but is also Universal.

U-DF - Denotes muffler used primarily as Universal, but is also Direct Fit.

DF - Direct Fit Muffler

U - Universal Muffler

HS - Denotes Heat Shield is on muffler.

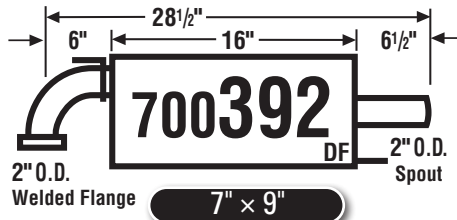
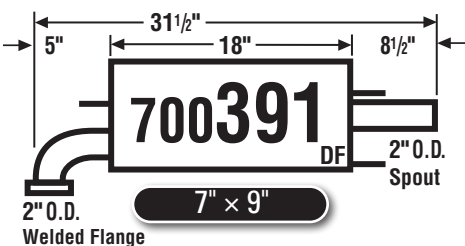
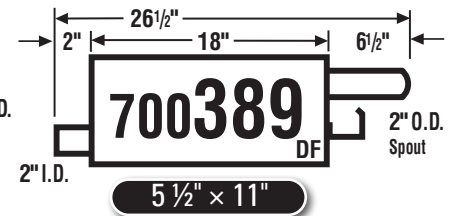
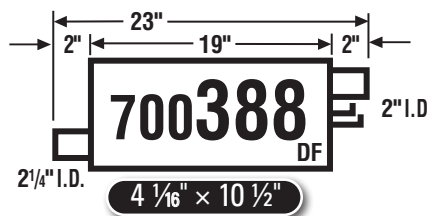
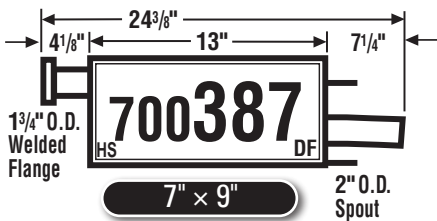
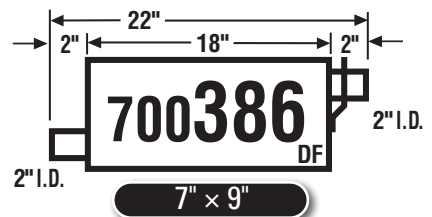
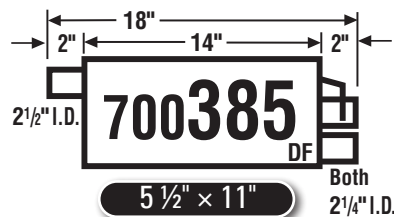
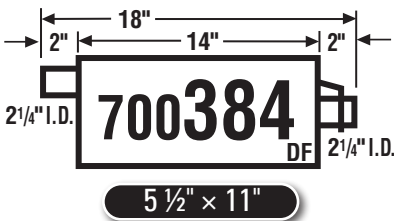
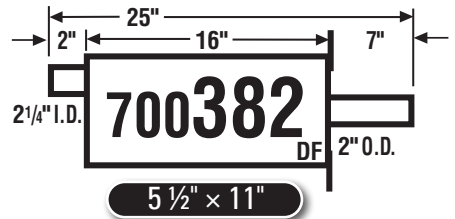
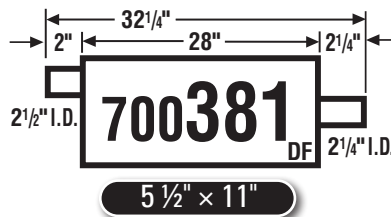
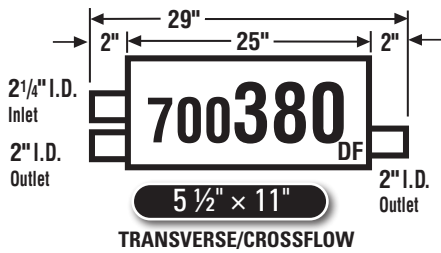
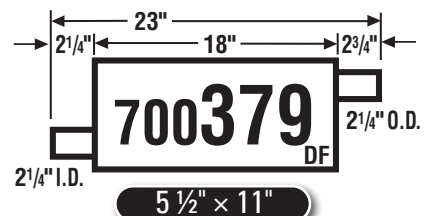
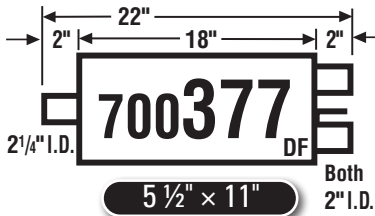
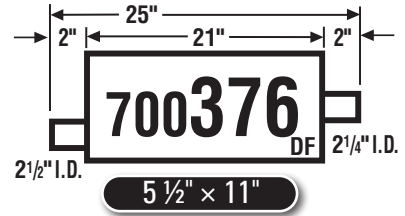
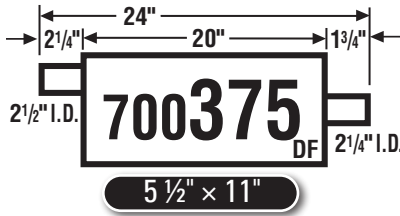
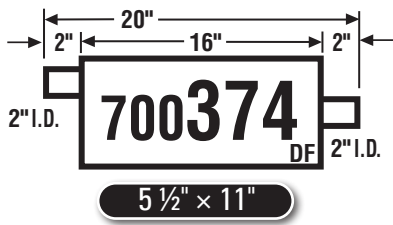

NOTE: Black area denotes welded head bracket.

DF-U - Denotes muffler used primarily as Direct Fit, but is also Universal.

U-DF - Denotes muffler used primarily as Universal, but is also Direct Fit.

DF - Direct Fit Muffler

U - Universal Muffler

HS - Denotes Heat Shield is on muffler.

MUFFLER SPECS

by PART NUMBER

MAXIMUM **TMSL**

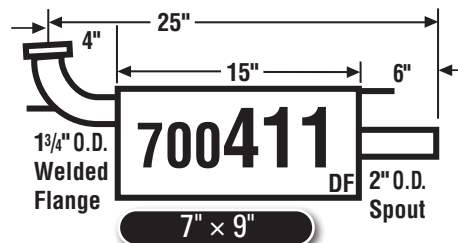
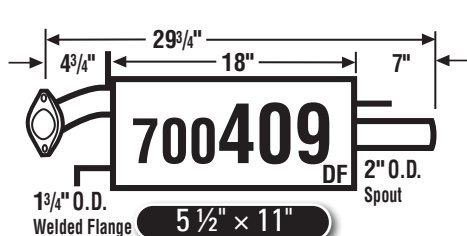
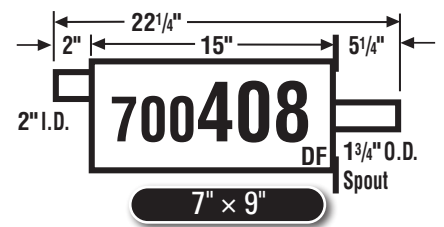
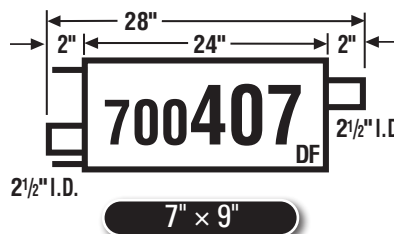
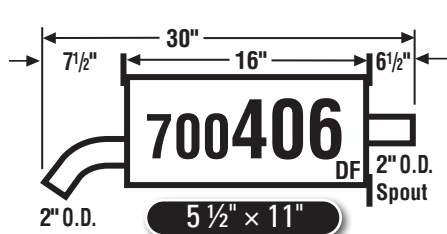
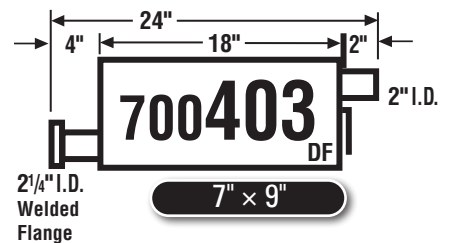
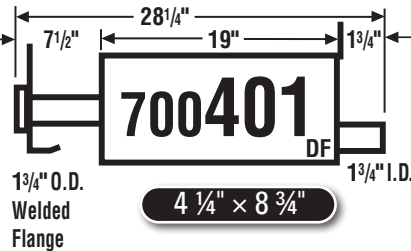
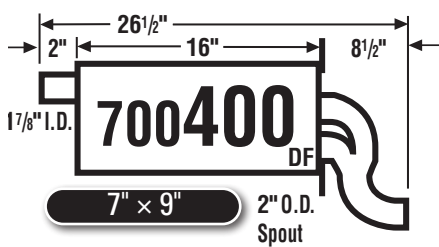
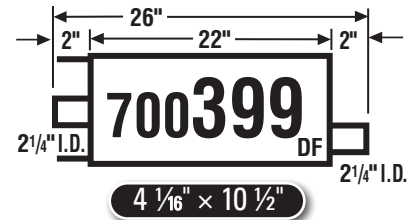
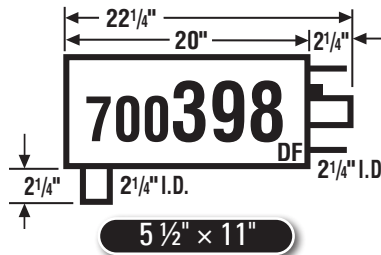
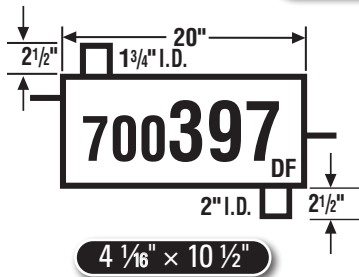
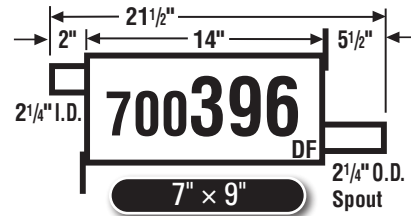
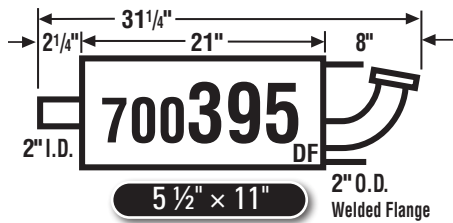
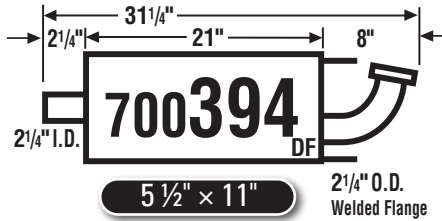
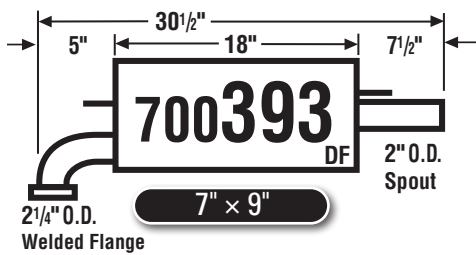

NOTE: Black area denotes welded head bracket.

DF-U - Denotes muffler used primarily as Direct Fit, but is also Universal.

U-DF - Denotes muffler used primarily as Universal, but is also Direct Fit.

DF - Direct Fit Muffler

U - Universal Muffler

HS - Denotes Heat Shield is on muffler.

MSL BY PART NUMBER

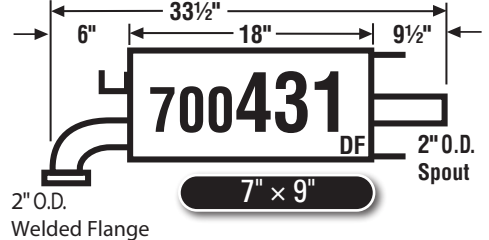
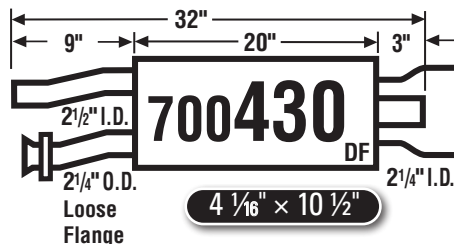
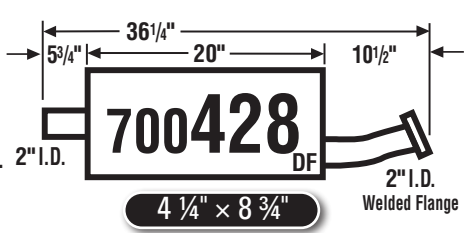
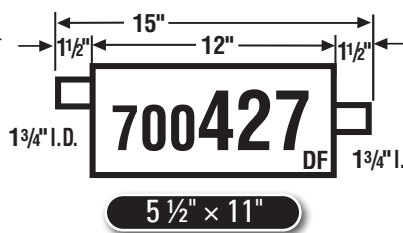
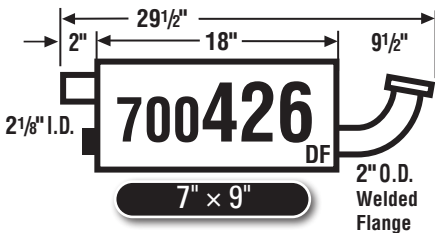
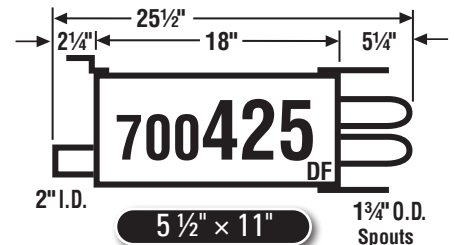
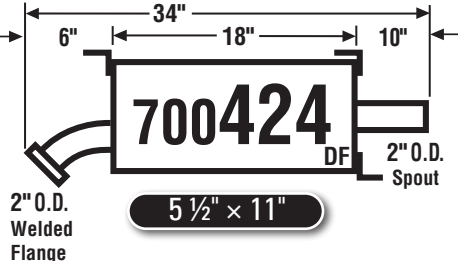
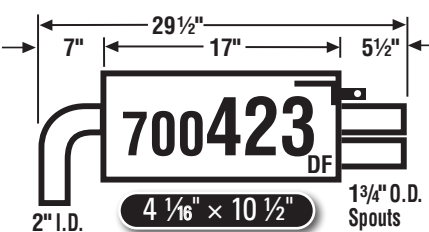
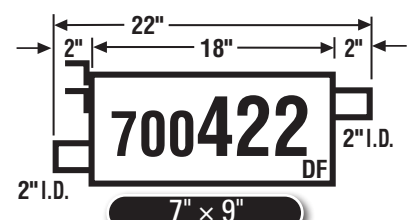
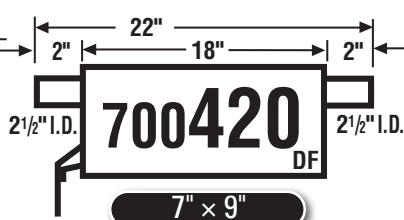
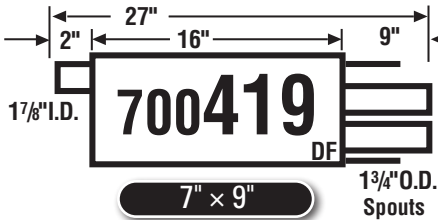
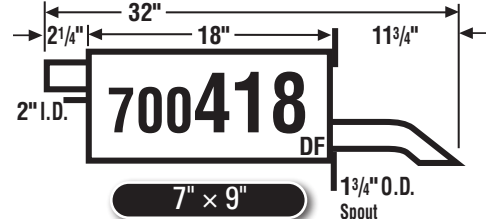
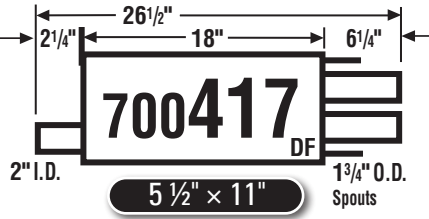
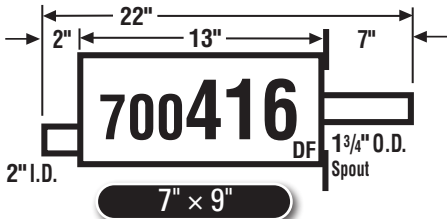
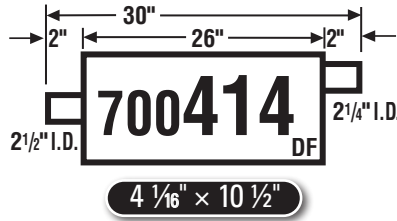
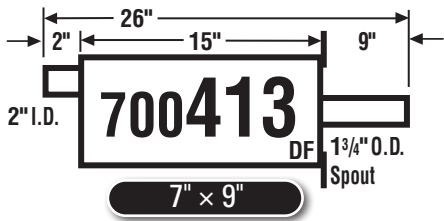

NOTE: Black area denotes welded head bracket.

DF-U - Denotes muffler used primarily as Direct Fit, but is also Universal.
 U-DF - Denotes muffler used primarily as Universal, but is also Direct Fit.

DF - Direct Fit Muffler
 U - Universal Muffler
 HS - Denotes Heat Shield is on muffler.

MUFFLER SPECS

by PART NUMBER

MAXIMUM **MSL**[®]

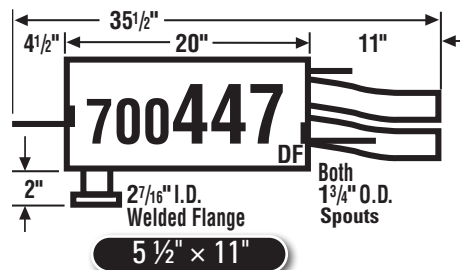
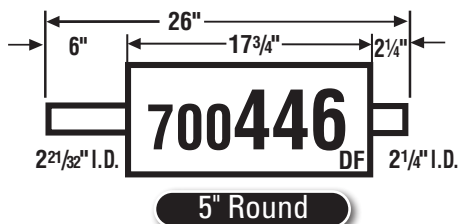
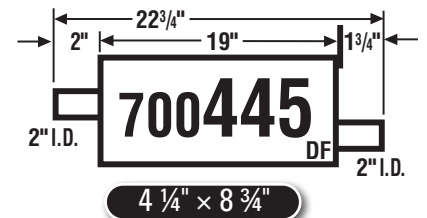
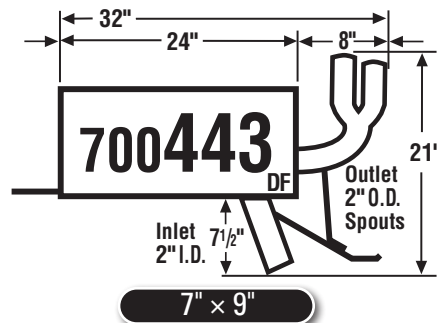
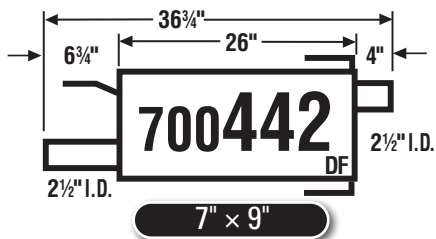
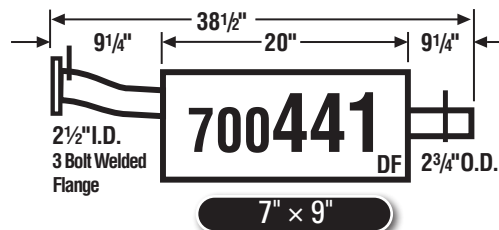
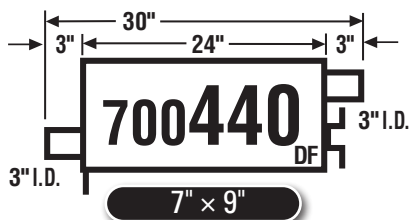
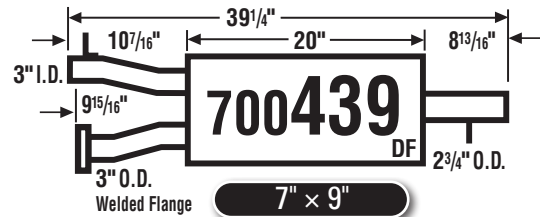
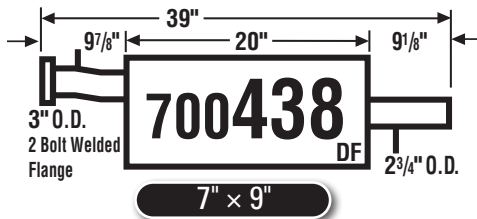
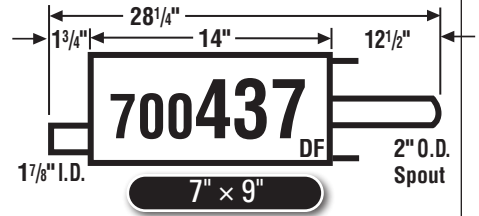
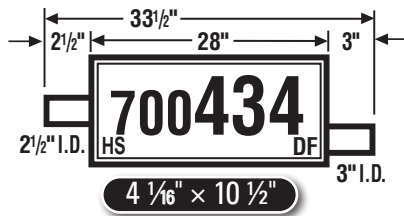
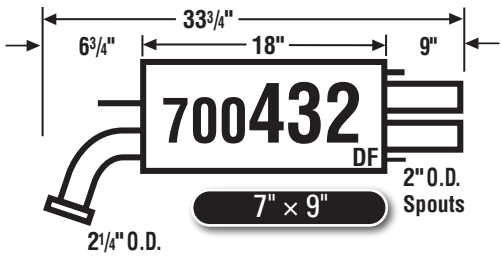

MSL BY PART NUMBER

NOTE: Black area denotes welded head bracket.

DF-U - Denotes muffler used primarily as Direct Fit, but is also Universal.

U-DF - Denotes muffler used primarily as Universal, but is also Direct Fit.

DF - Direct Fit Muffler

U - Universal Muffler

HS - Denotes Heat Shield is on muffler.

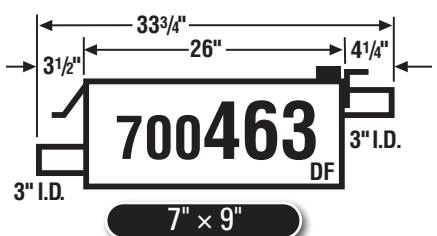
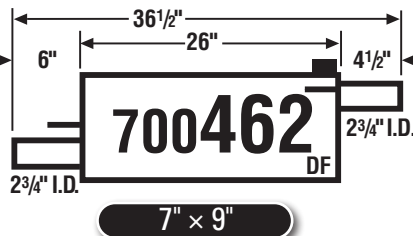
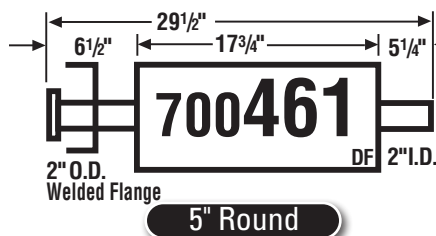
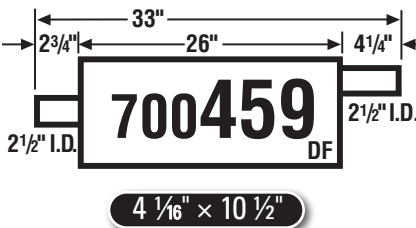
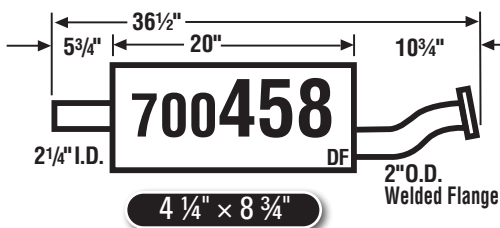
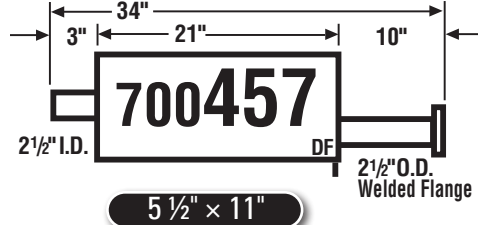
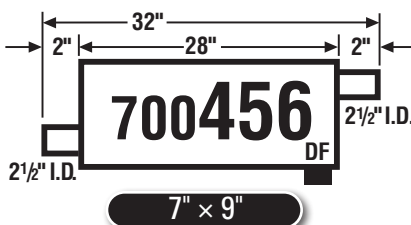
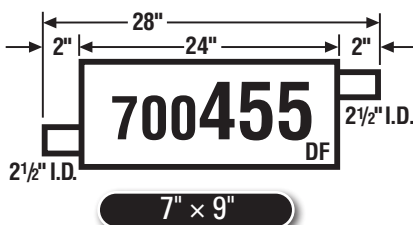
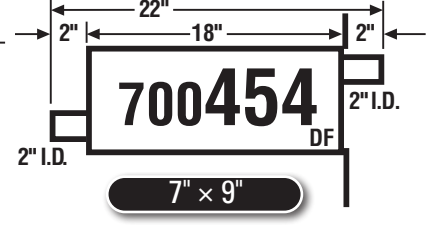
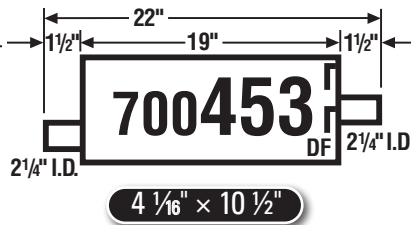
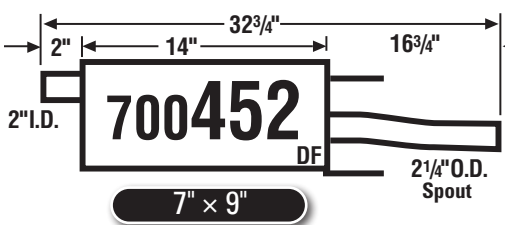
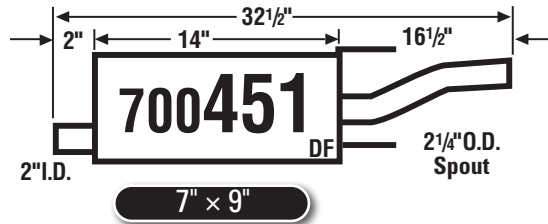
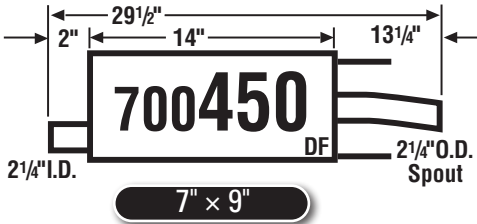
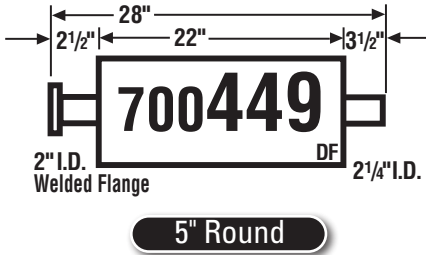
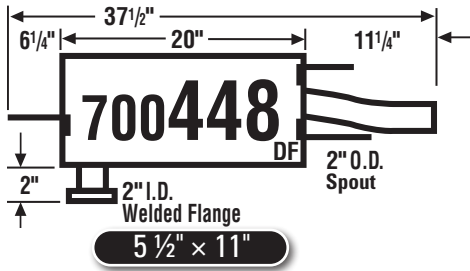

NOTE: Black area denotes welded head bracket.

DF-U - Denotes muffler used primarily as Direct Fit, but is also Universal.

U-DF - Denotes muffler used primarily as Universal, but is also Direct Fit.

DF - Direct Fit Muffler

U - Universal Muffler

HS - Denotes Heat Shield is on muffler.

MUFFLER SPECS by PART NUMBER

MAXIMUM **TMSL**

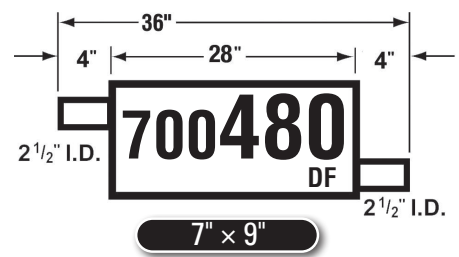
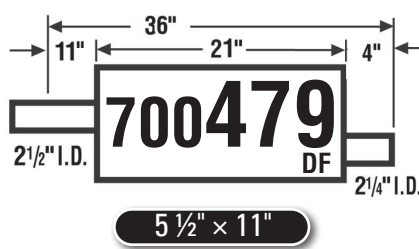
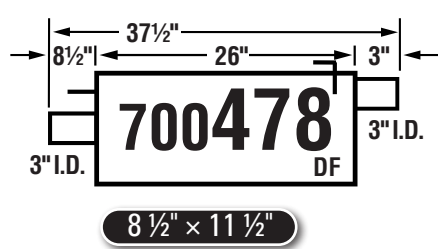
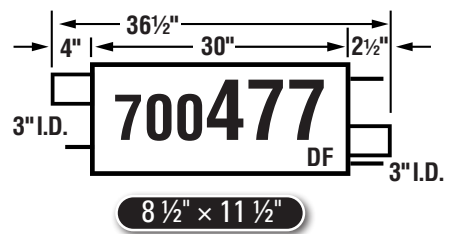
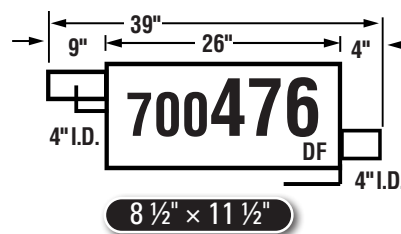
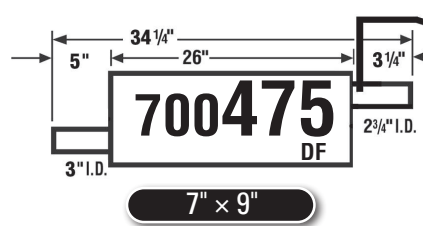
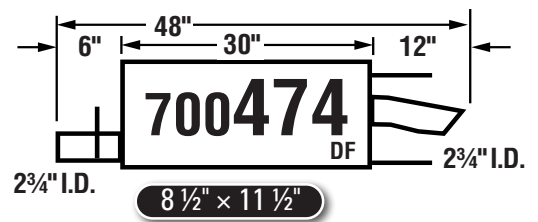
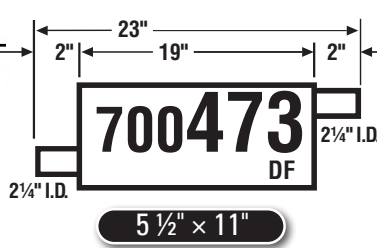
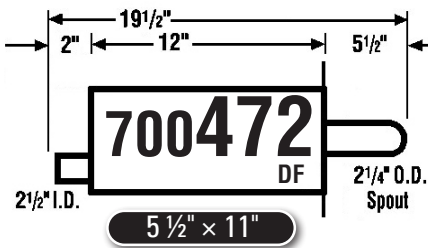
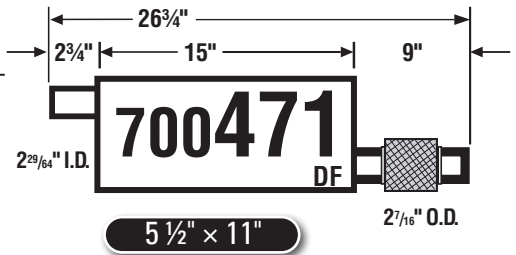
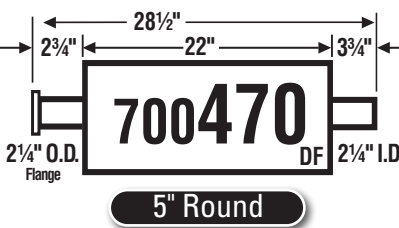
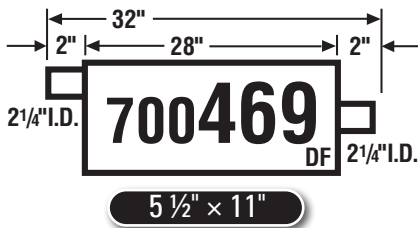
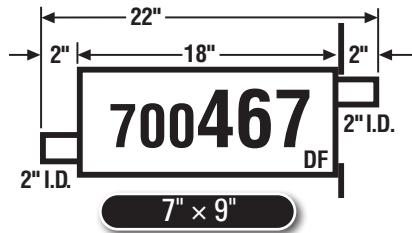
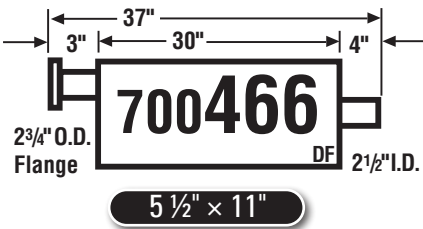

NOTE: Black area denotes welded head bracket.

DF-U - Denotes muffler used primarily as Direct Fit, but is also Universal.
U-DF - Denotes muffler used primarily as Universal, but is also Direct Fit.

DF - Direct Fit Muffler
U - Universal Muffler
HS - Denotes Heat Shield is on muffler.

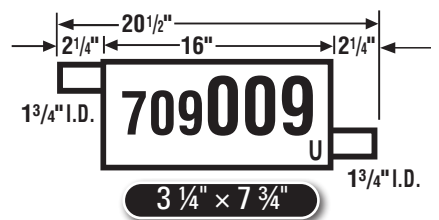
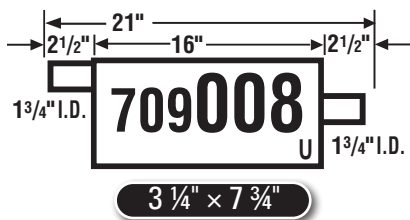
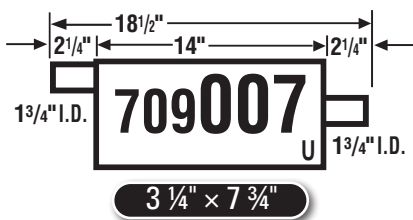
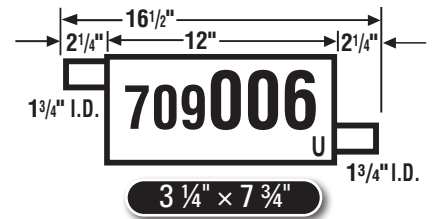
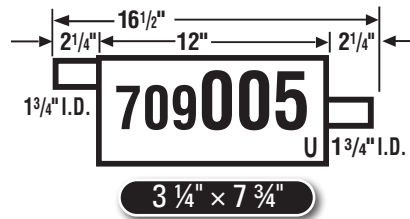
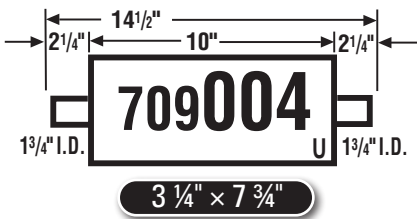
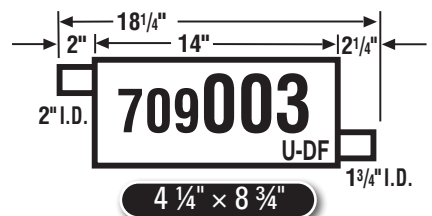
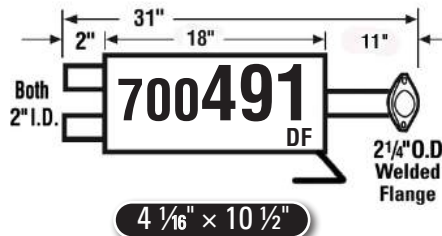
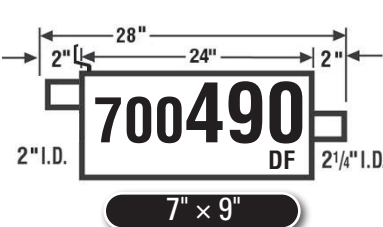
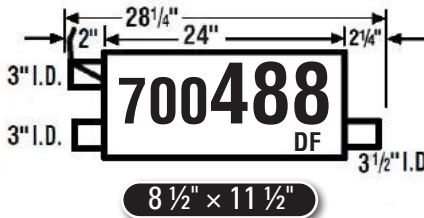
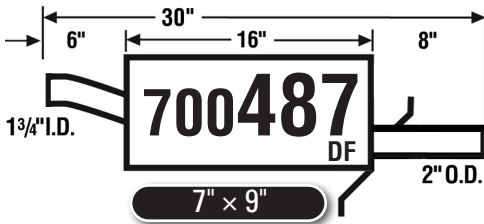
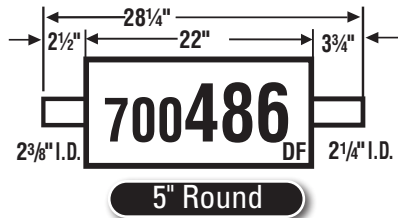
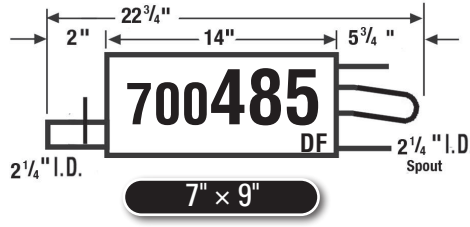
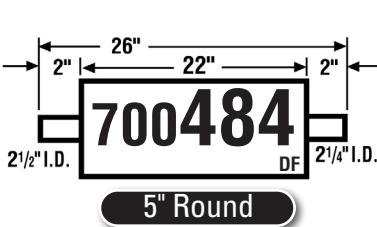
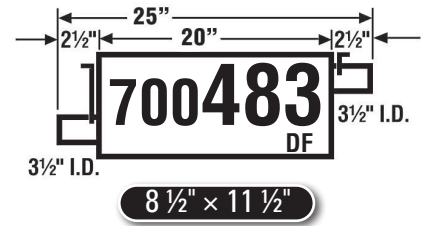
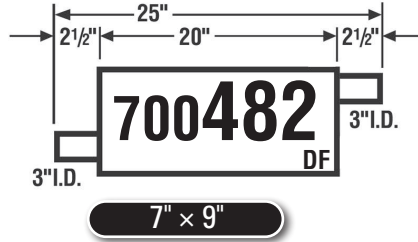
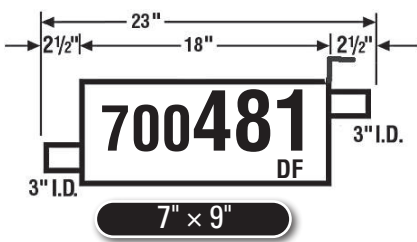

NOTE: Black area denotes welded head bracket.

DF-U - Denotes muffler used primarily as Direct Fit, but is also Universal.

U-DF - Denotes muffler used primarily as Universal, but is also Direct Fit.

DF - Direct Fit Muffler

U - Universal Muffler

HS - Denotes Heat Shield is on muffler.

MUFFLER SPECS

by PART NUMBER

MAXIMUM **MSL**[®]

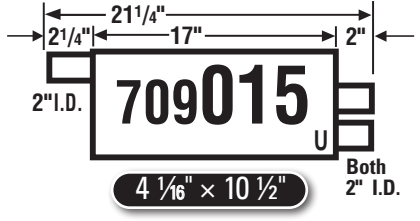
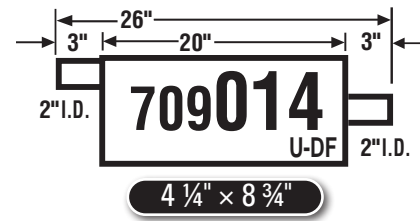
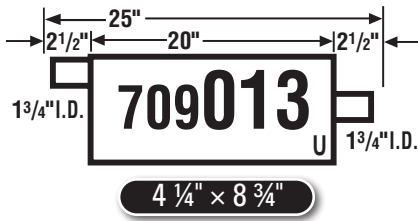
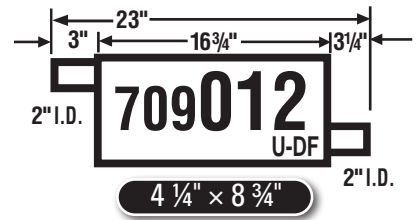
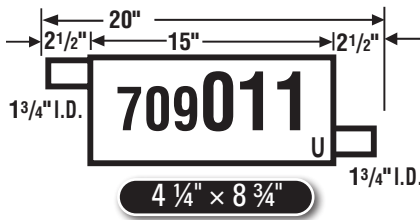
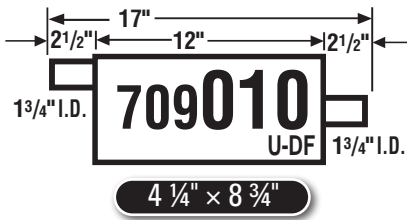

Both
2" I.D.

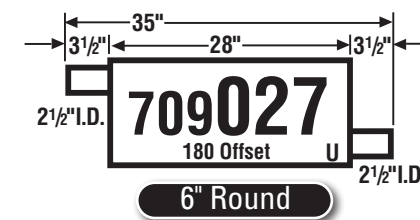
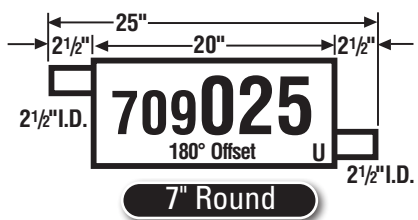
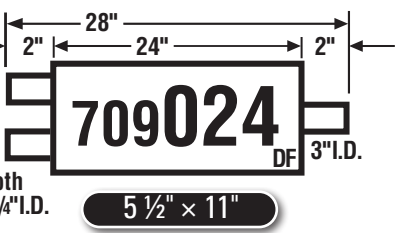
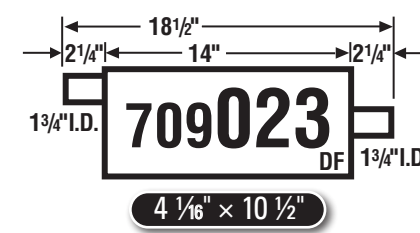
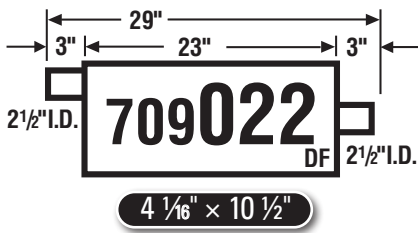
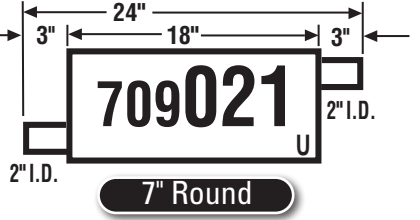
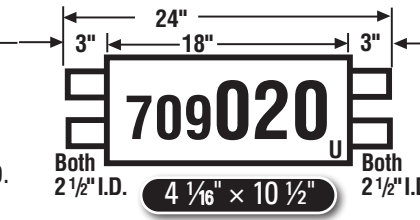
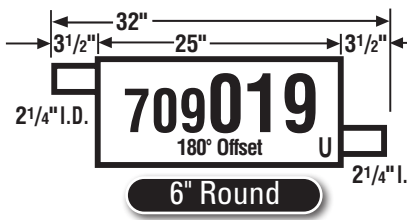
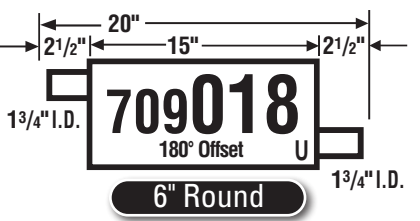
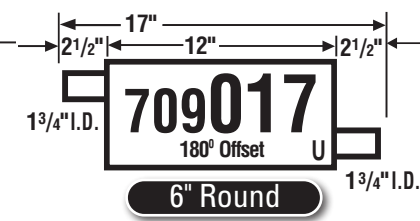
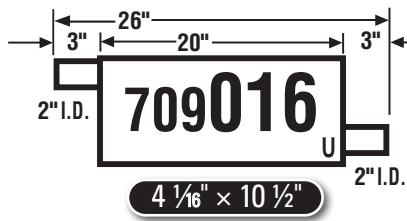

MSL BY PART NUMBER

NOTE: Black area denotes welded head bracket.

DF-U - Denotes muffler used primarily as Direct Fit, but is also Universal.

U-DF - Denotes muffler used primarily as Universal, but is also Direct Fit.

DF - Direct Fit Muffler

U - Universal Muffler

HS - Denotes Heat Shield is on muffler.

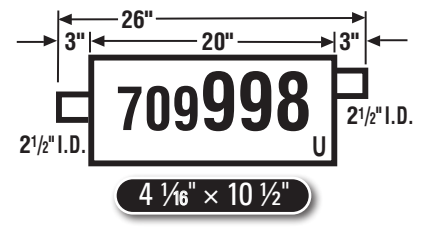
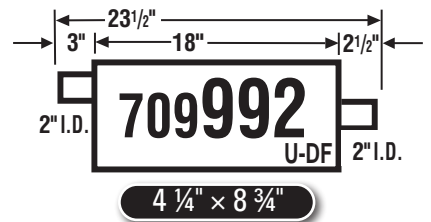
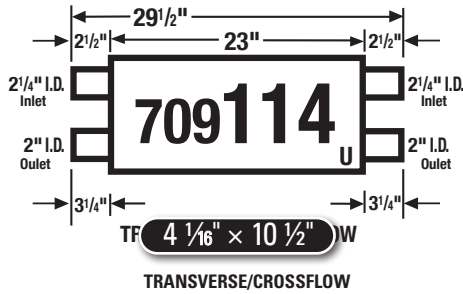
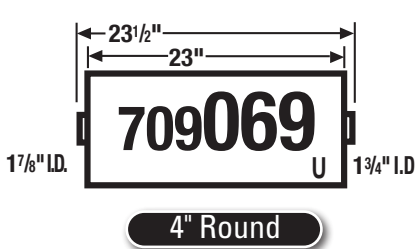
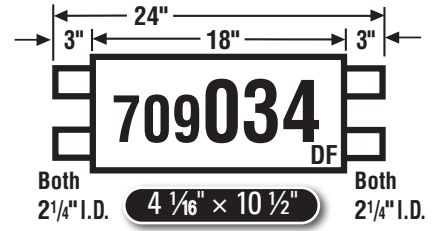
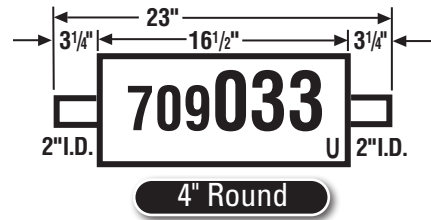
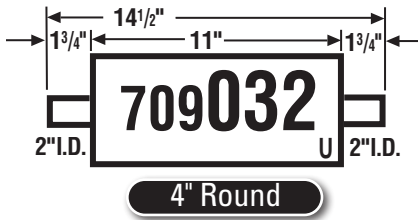
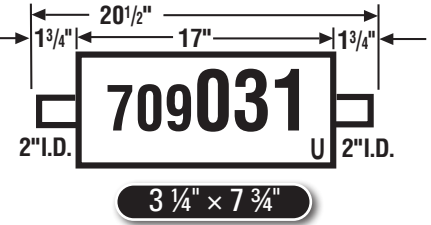
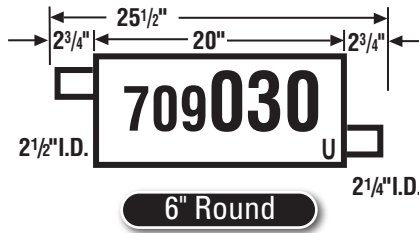
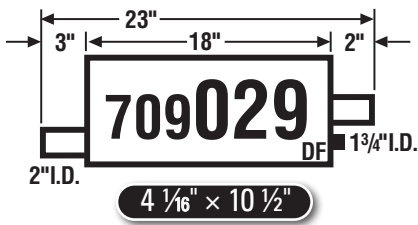

NOTE: Black area denotes welded head bracket.

DF-U - Denotes muffler used primarily as Direct Fit, but is also Universal.

U-DF - Denotes muffler used primarily as Universal, but is also Direct Fit.

DF - Direct Fit Muffler

U - Universal Muffler

HS - Denotes Heat Shield is on muffler.

UNIVERSAL SPECS

by DIMENSION

Sorted first by Cross Section, then Shell Length, then Inlet Diameter.

MAXIMUM **TMSL**®

4" ROUNDS

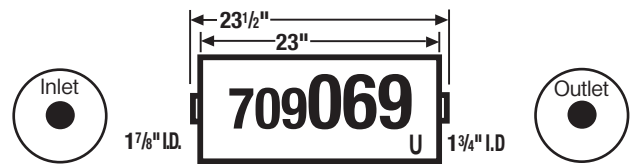
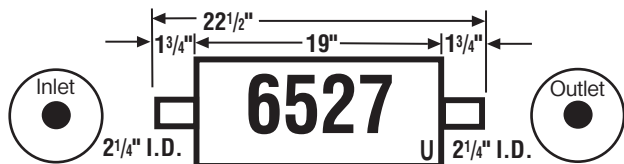
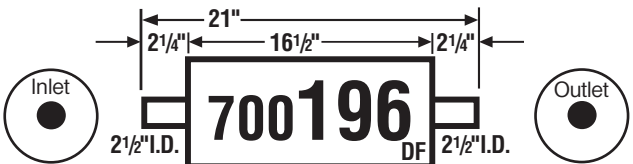
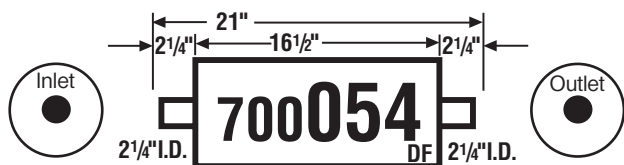
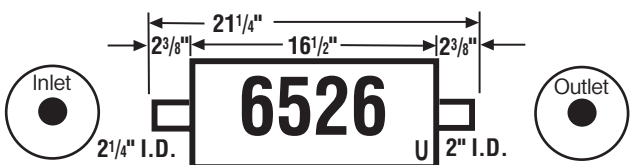
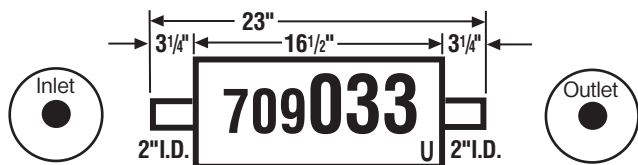
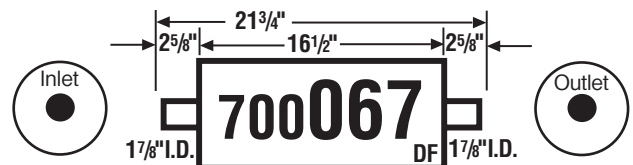
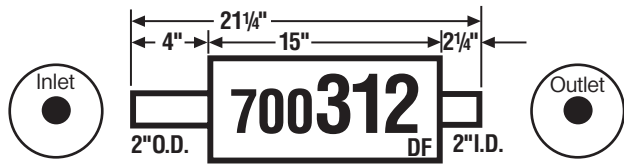
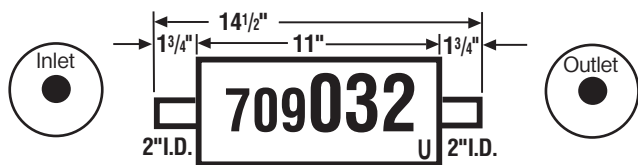

MSL BY DIMENSION

NOTE: Black area denotes welded head bracket.

DF-U - Denotes muffler used primarily as Direct Fit, but is also Universal.

U-DF - Denotes muffler used primarily as Universal, but is also Direct Fit.

DF - Direct Fit Muffler

U - Universal Muffler

HS - Denotes Heat Shield is on muffler.

5" ROUNDS

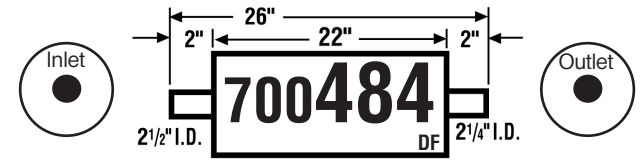
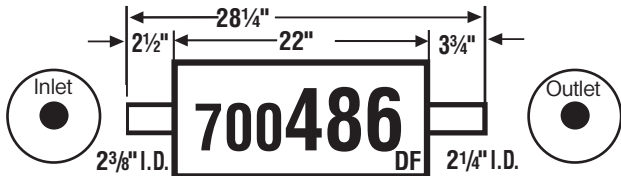
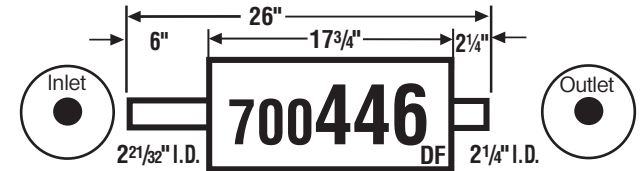
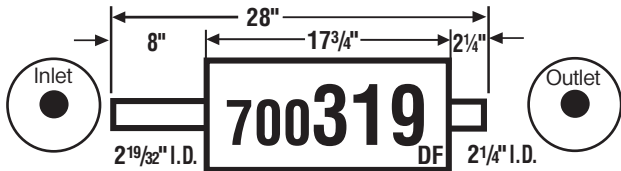
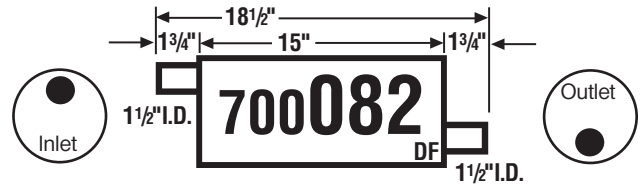
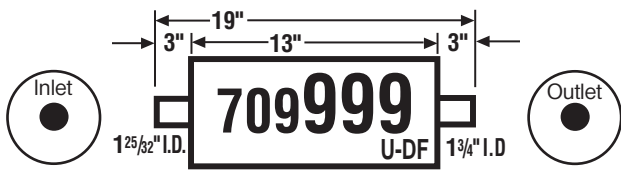

6" ROUNDS

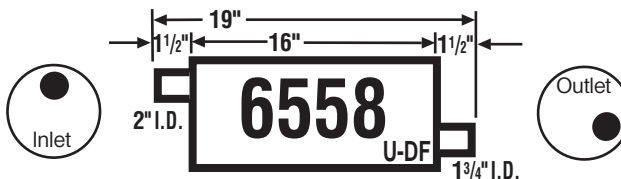
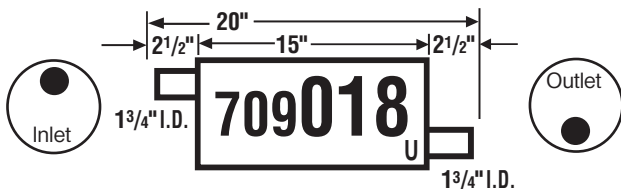
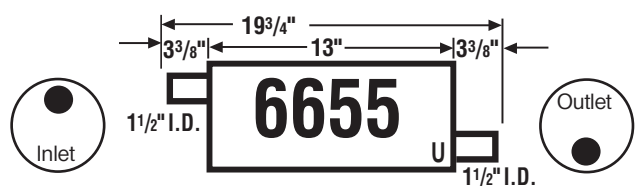
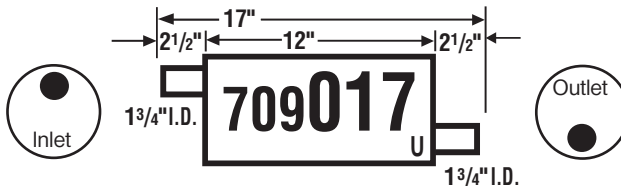

MSL BY DIMENSION

NOTE: Black area denotes welded head bracket.

DF-U - Denotes muffler used primarily as Direct Fit, but is also Universal.

U-DF - Denotes muffler used primarily as Universal, but is also Direct Fit.

DF - Direct Fit Muffler

U - Universal Muffler

HS - Denotes Heat Shield is on muffler.

UNIVERSAL SPECS

by DIMENSION

Sorted first by Cross Section, then Shell Length, then Inlet Diameter.

MAXIMUM **TMSL**

6" ROUNDS

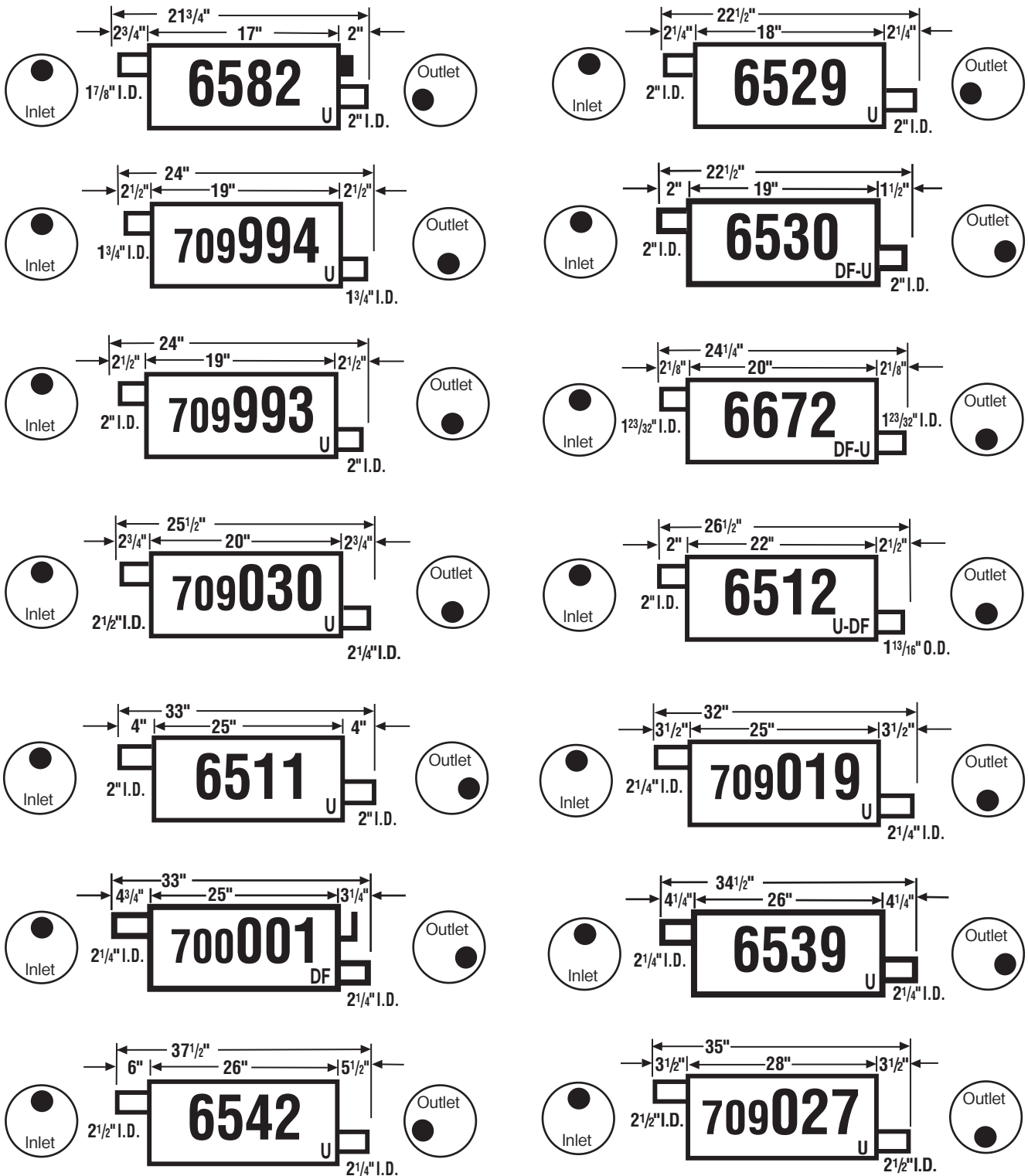

NOTE: Black area denotes welded head bracket.

DF-U - Denotes muffler used primarily as Direct Fit, but is also Universal.

U-DF - Denotes muffler used primarily as Universal, but is also Direct Fit.

DF - Direct Fit Muffler

U - Universal Muffler

HS - Denotes Heat Shield is on muffler.

MSL BY DIMENSION

7" ROUNDS

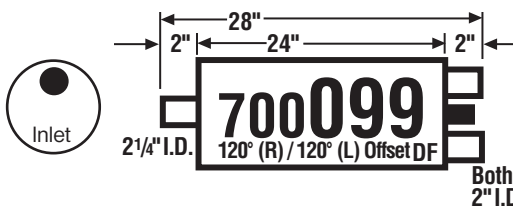
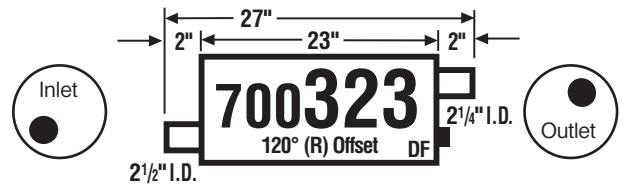
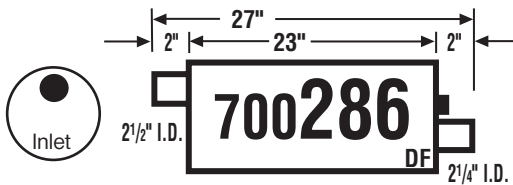
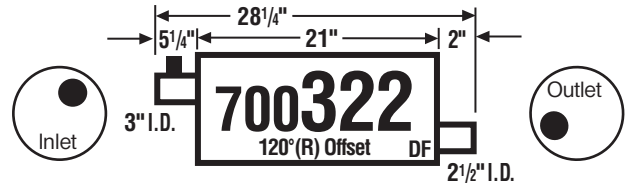
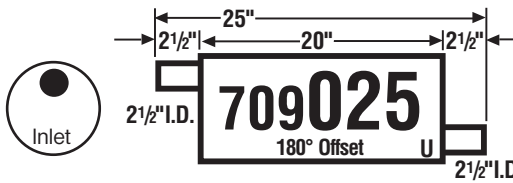
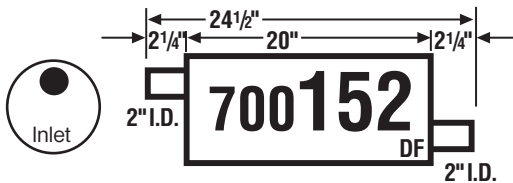
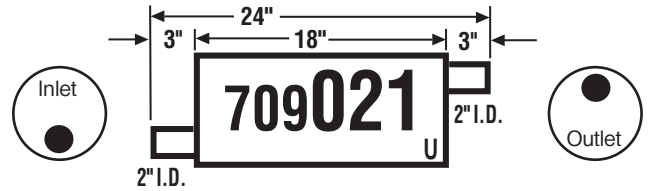
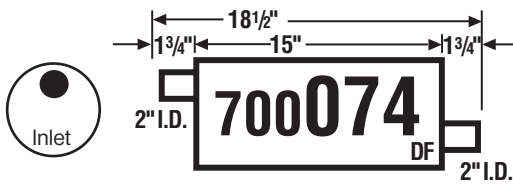
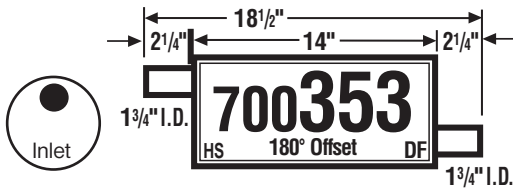

MSL BY DIMENSION

NOTE: Black area denotes welded head bracket.

DF-U - Denotes muffler used primarily as Direct Fit, but is also Universal.

U-DF - Denotes muffler used primarily as Universal, but is also Direct Fit.

DF - Direct Fit Muffler

U - Universal Muffler

HS - Denotes Heat Shield is on muffler.

UNIVERSAL SPECS

by DIMENSION

Sorted first by Cross Section, then Shell Length, then Inlet Diameter.

MAXIMUM **TMSL**

7" ROUNDS

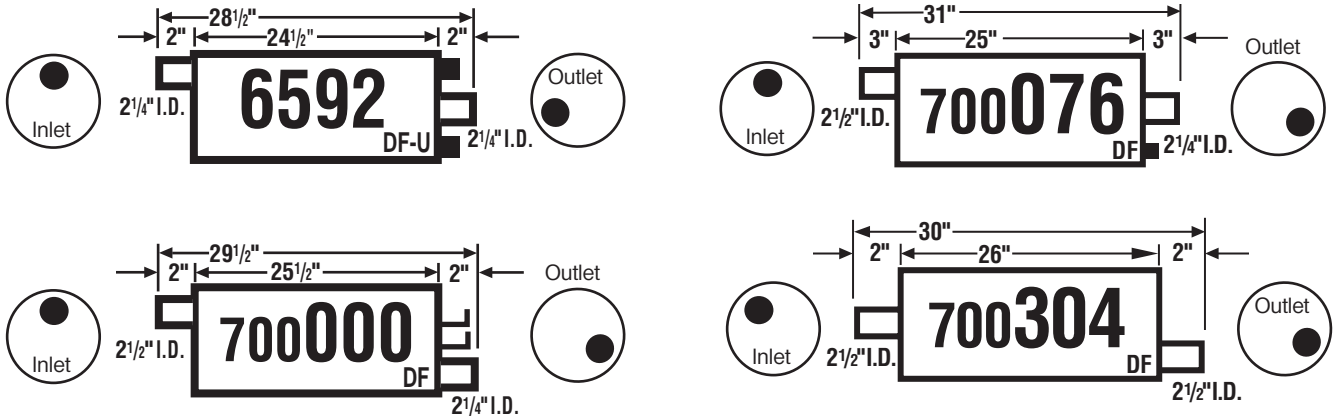

3 1/4" x 7 3/4" OVALS

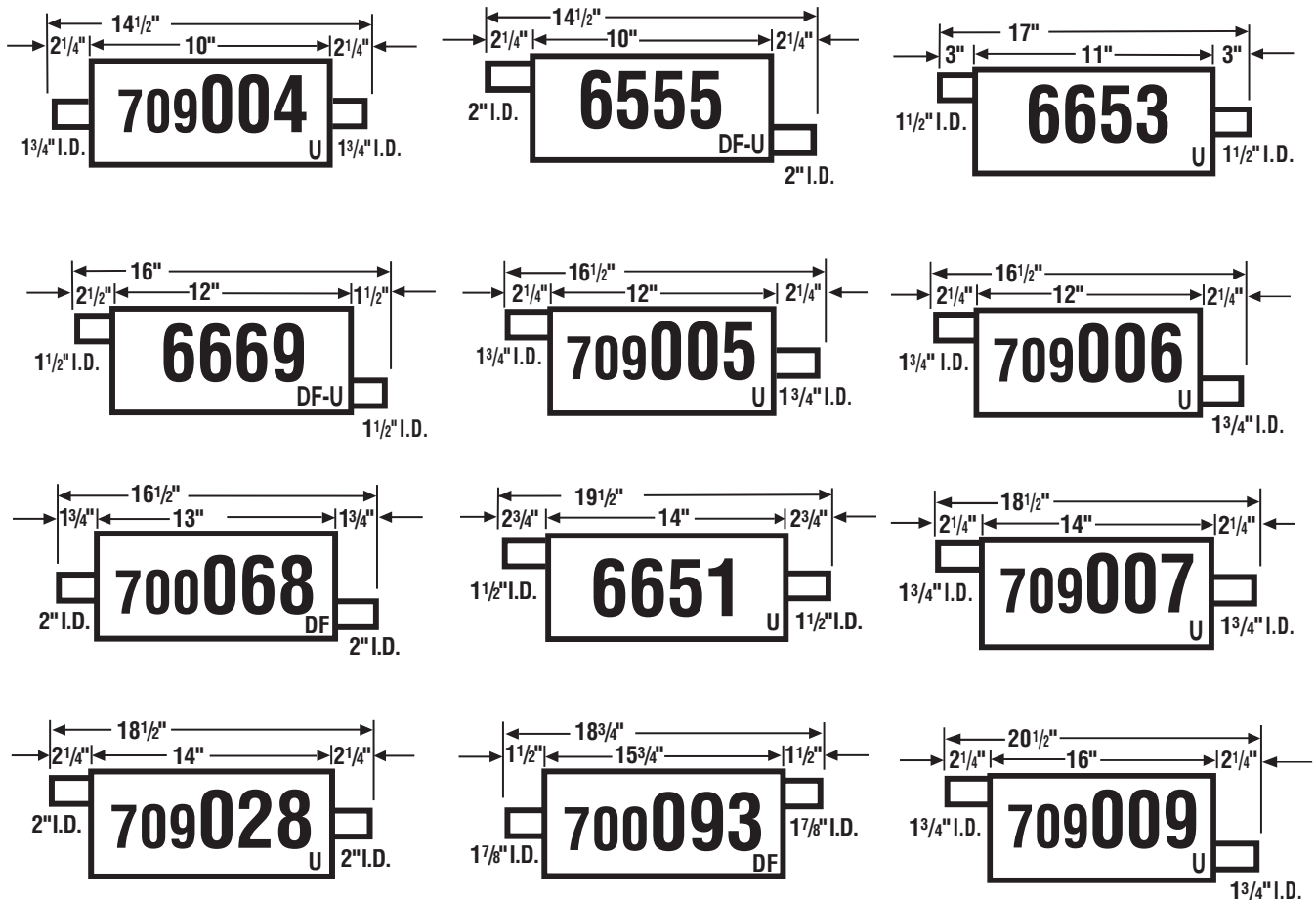

NOTE: Black area denotes welded head bracket.

DF-U - Denotes muffler used primarily as Direct Fit, but is also Universal.

U-DF - Denotes muffler used primarily as Universal, but is also Direct Fit.

DF - Direct Fit Muffler

U - Universal Muffler

HS - Denotes Heat Shield is on muffler.

MSL BY DIMENSION

3 1/4" x 7 3/4" OVALS

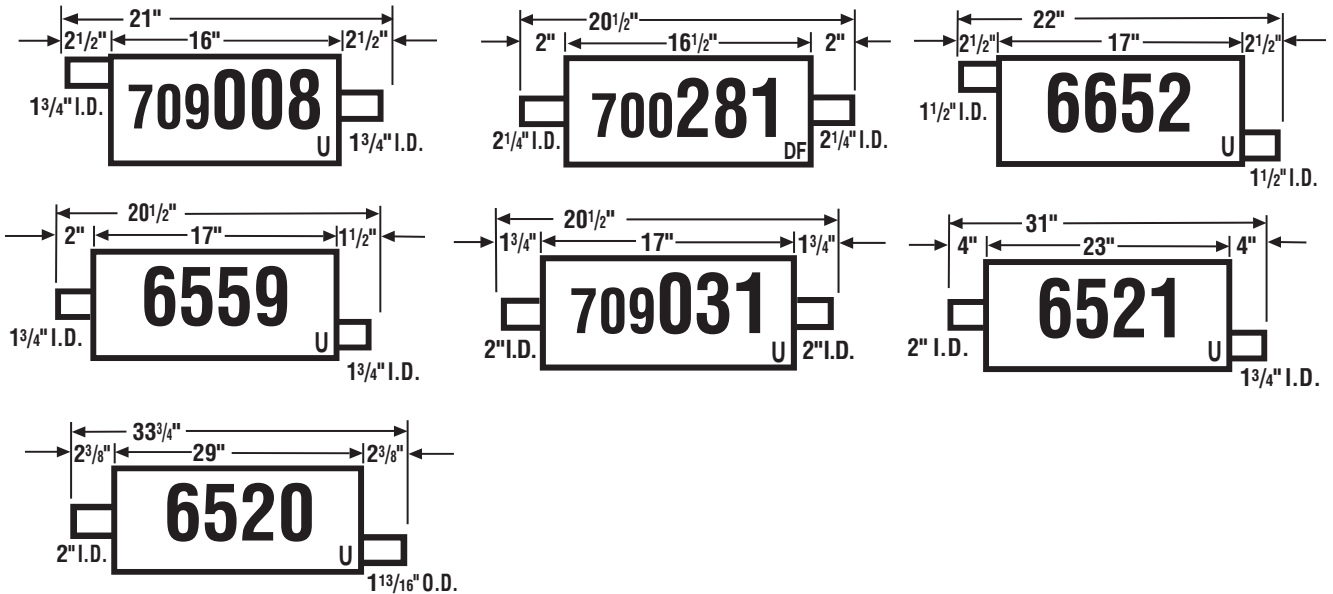

4 1/4" x 8 3/4" OVALS

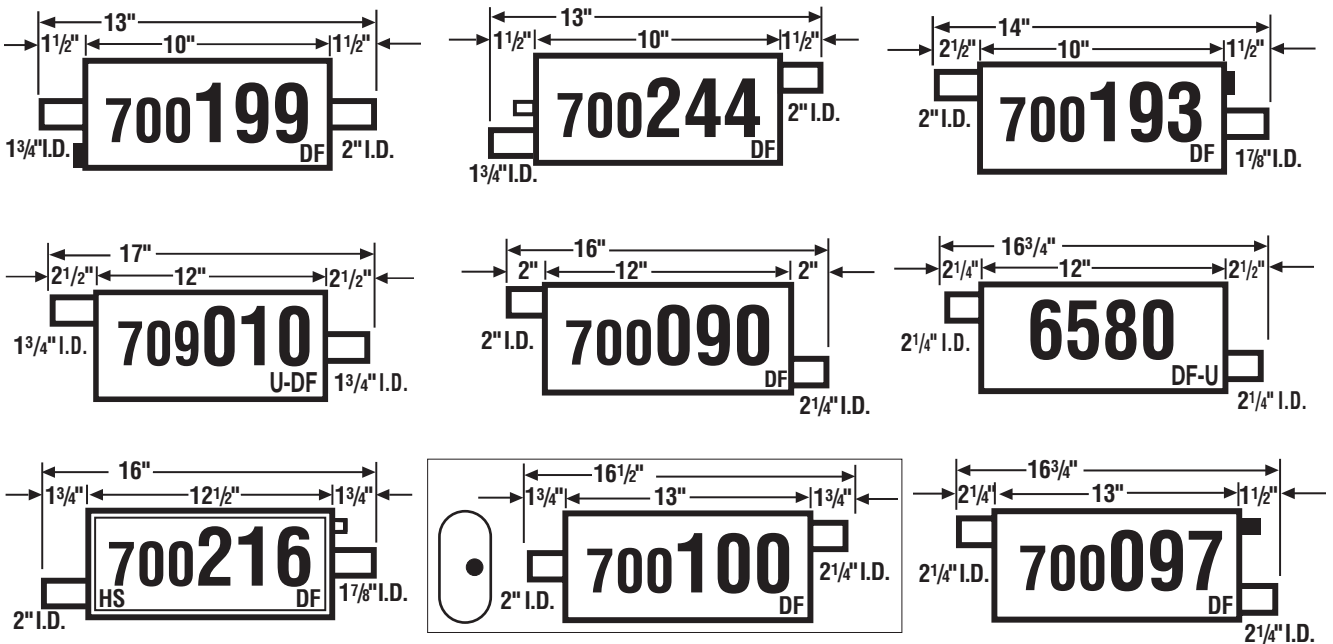

MSL BY DIMENSION

NOTE: Black area denotes welded head bracket.

DF-U - Denotes muffler used primarily as Direct Fit, but is also Universal.

U-DF - Denotes muffler used primarily as Universal, but is also Direct Fit.

DF - Direct Fit Muffler

U - Universal Muffler

HS - Denotes Heat Shield is on muffler.

UNIVERSAL SPECS

by DIMENSION

Sorted first by Cross Section, then Shell Length, then Inlet Diameter.

MAXIMUM **TMSL**

4 1/4" x 8 3/4" OVALS

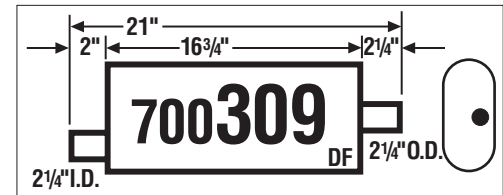
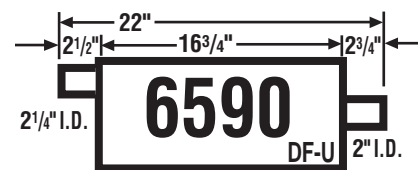
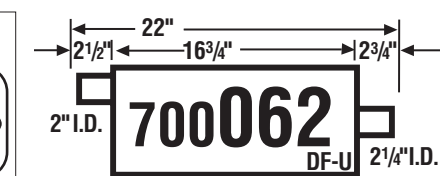
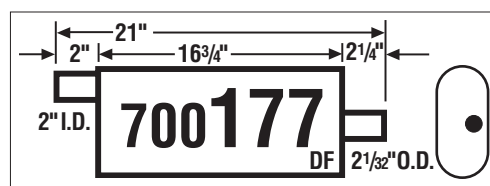
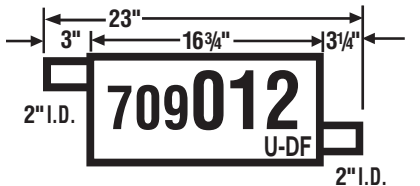
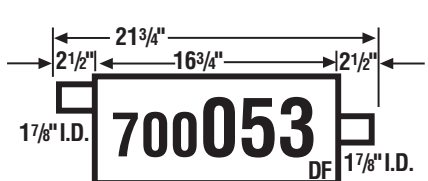
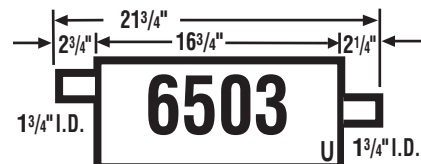
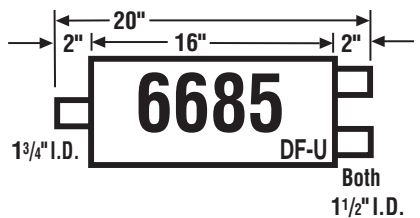
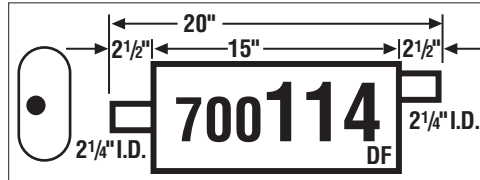
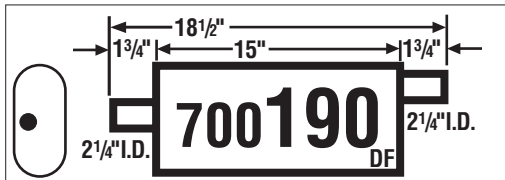
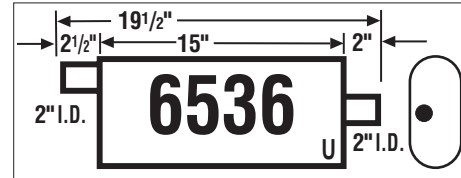
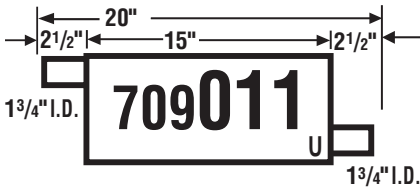
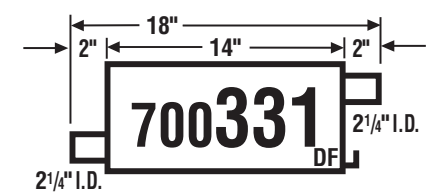
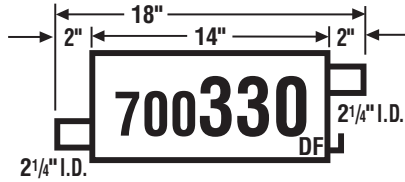
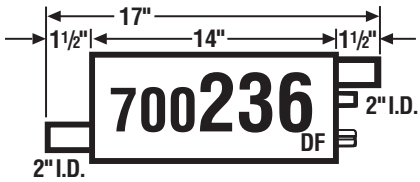
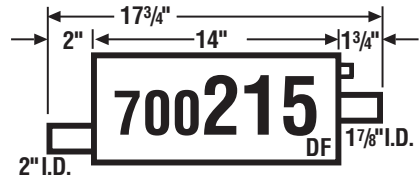
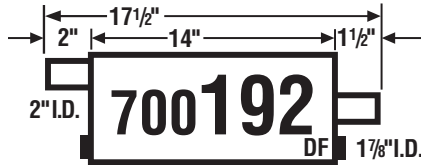
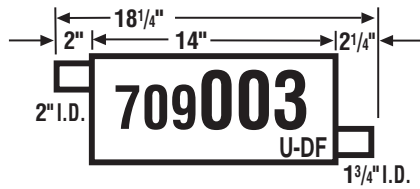

NOTE: Black area denotes welded head bracket.

DF-U - Denotes muffler used primarily as Direct Fit, but is also Universal.

U-DF - Denotes muffler used primarily as Universal, but is also Direct Fit.

DF - Direct Fit Muffler

U - Universal Muffler

HS - Denotes Heat Shield is on muffler.

MSL BY DIMENSION

4 1/4" x 8 3/4" OVALS

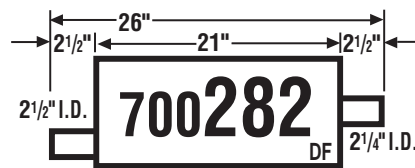
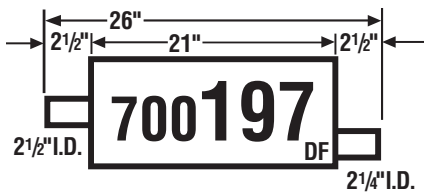
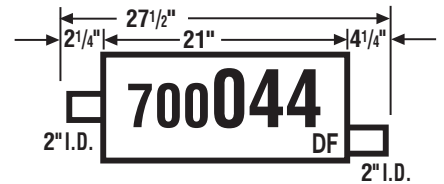
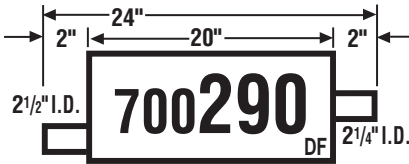
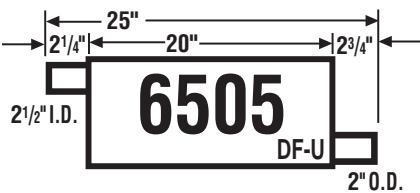
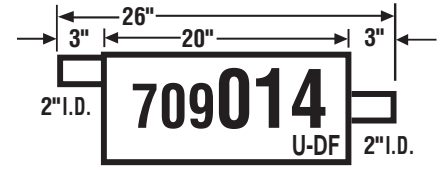
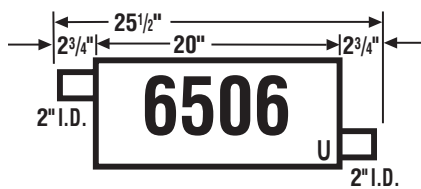
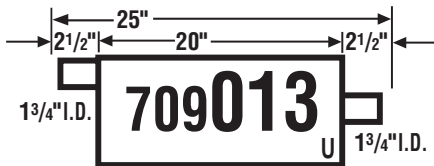
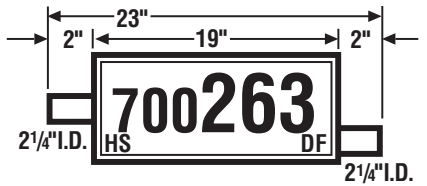
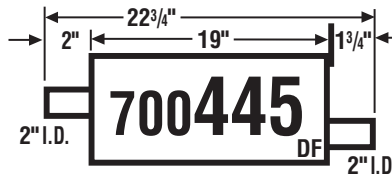
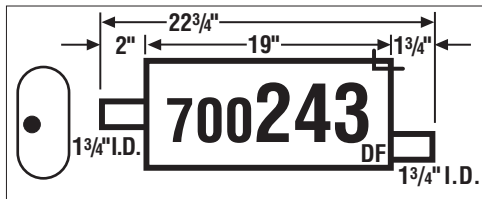
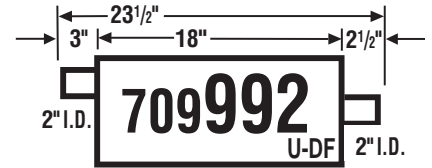
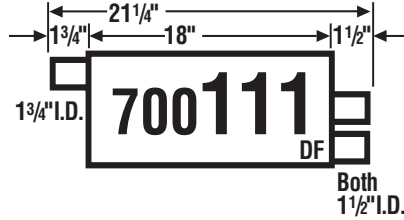
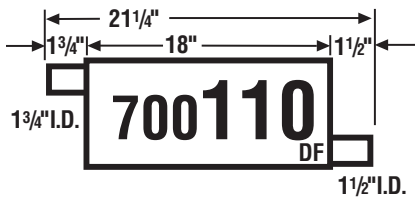

MSL BY DIMENSION

NOTE: Black area denotes welded head bracket.

DF-U - Denotes muffler used primarily as Direct Fit, but is also Universal.

U-DF - Denotes muffler used primarily as Universal, but is also Direct Fit.

DF - Direct Fit Muffler

U - Universal Muffler

HS - Denotes Heat Shield is on muffler.

UNIVERSAL SPECS

by DIMENSION

Sorted first by Cross Section, then Shell Length, then Inlet Diameter.

MAXIMUM **TMSL**

4 1/16" x 10 1/2" OVALS

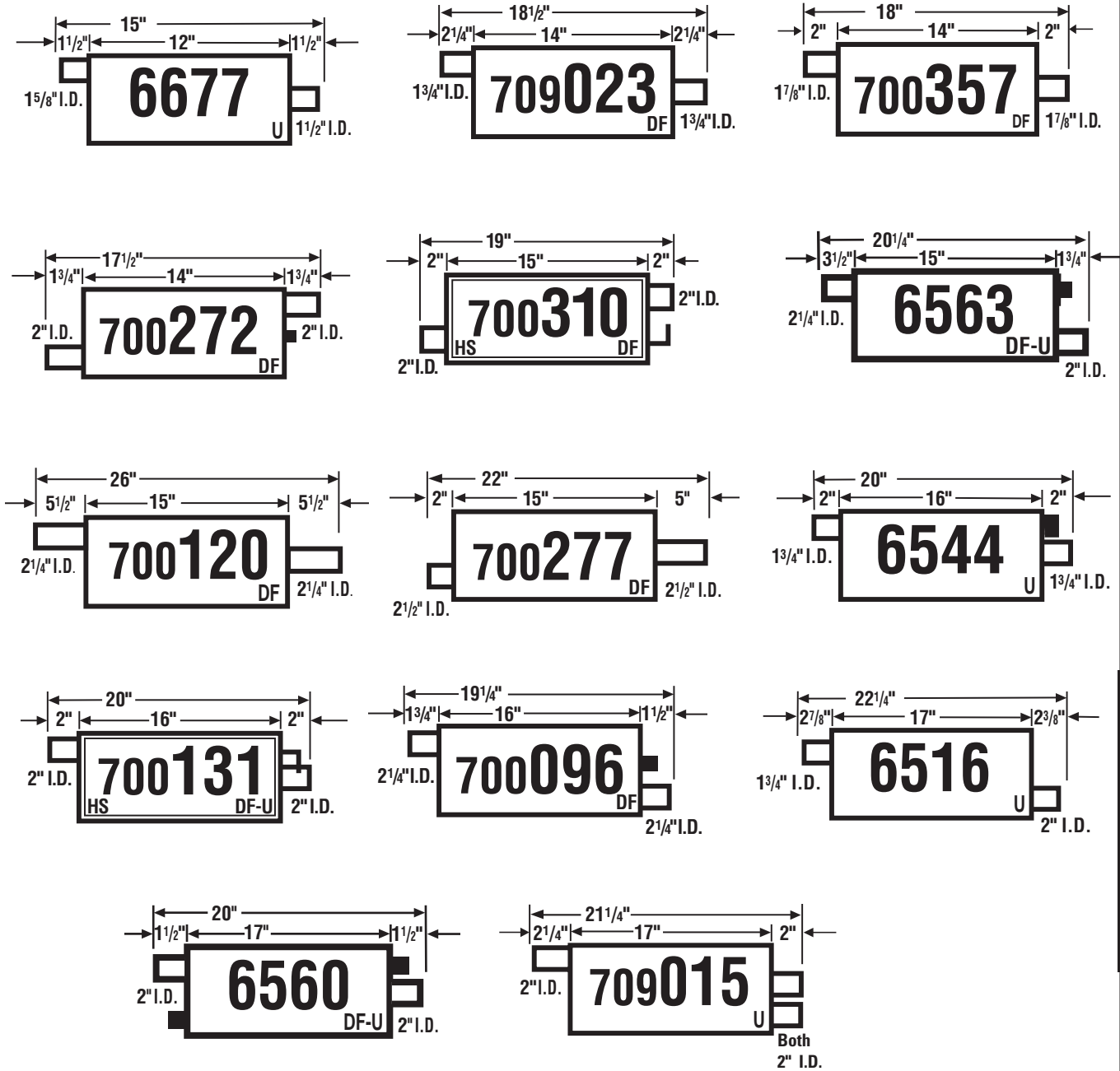

MSL BY DIMENSION

NOTE: Black area denotes welded head bracket.

DF-U - Denotes muffler used primarily as Direct Fit, but is also Universal.

U-DF - Denotes muffler used primarily as Universal, but is also Direct Fit.

DF - Direct Fit Muffler

U - Universal Muffler

HS - Denotes Heat Shield is on muffler.

4 1/16" x 10 1/2" OVALS

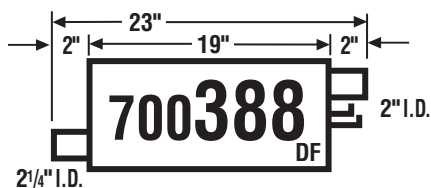
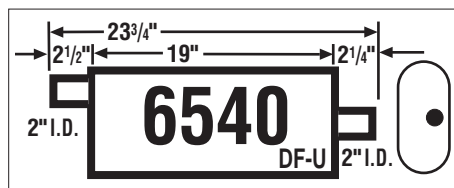
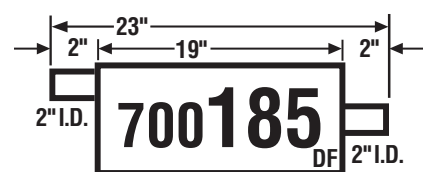
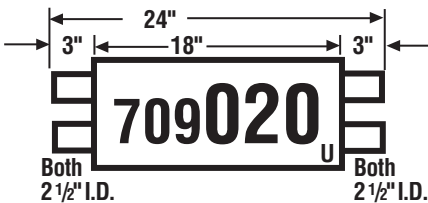
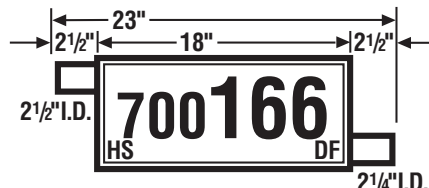
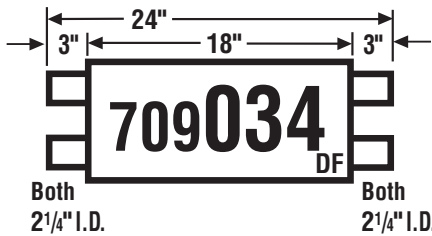
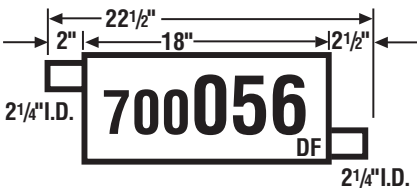
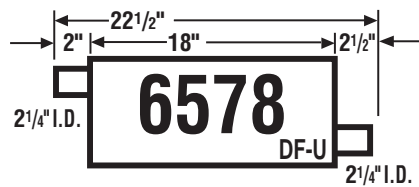
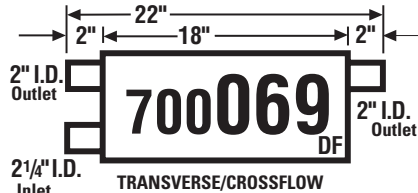
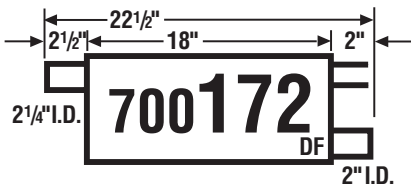
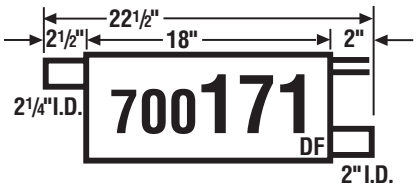
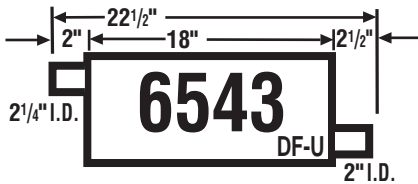
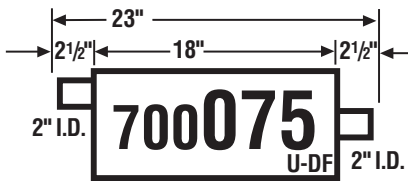
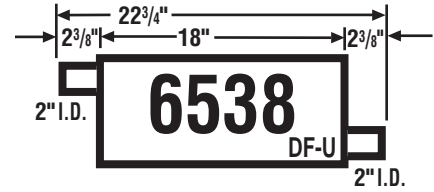
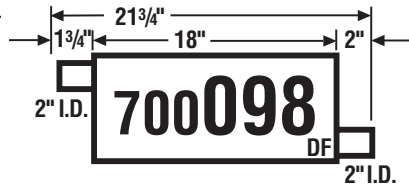
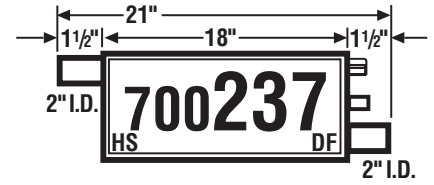
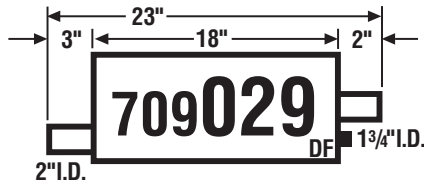
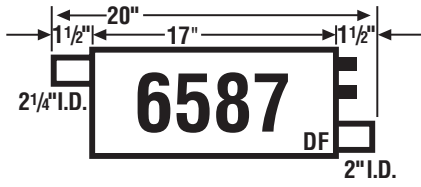

MSL BY DIMENSION

NOTE: Black area denotes welded head bracket.

DF-U - Denotes muffler used primarily as Direct Fit, but is also Universal.

U-DF - Denotes muffler used primarily as Universal, but is also Direct Fit.

DF - Direct Fit Muffler

U - Universal Muffler

HS - Denotes Heat Shield is on muffler.

UNIVERSAL SPECS

by DIMENSION

Sorted first by Cross Section, then Shell Length, then Inlet Diameter.

MAXIMUM **TMSL**

4 1/16" x 10 1/2" OVALS

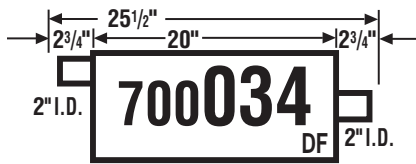
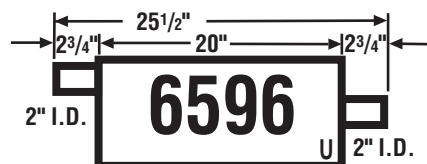
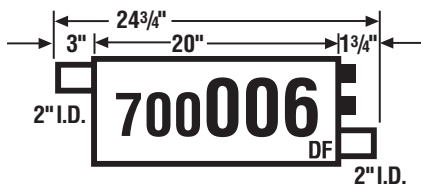
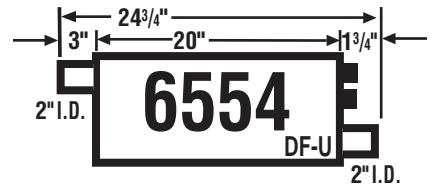
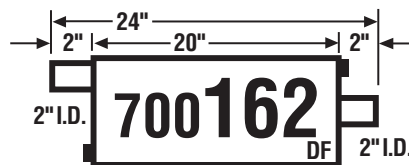
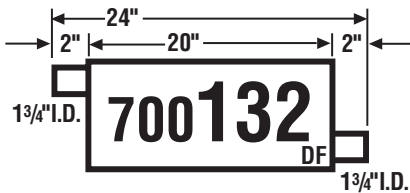
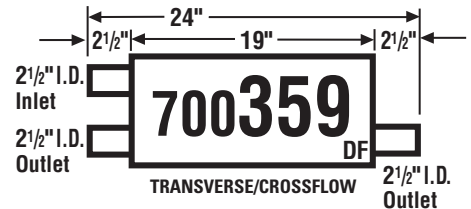
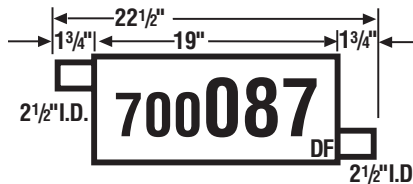
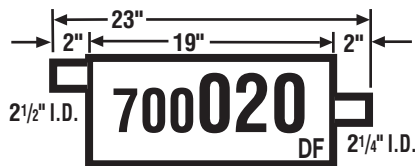
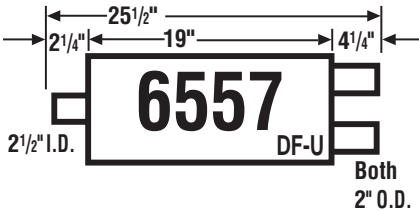
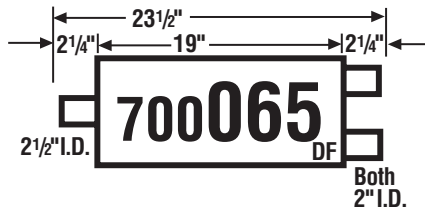
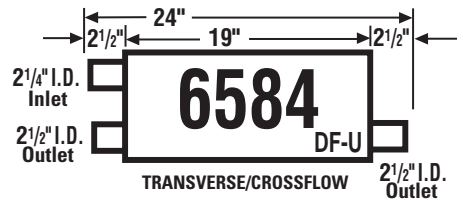
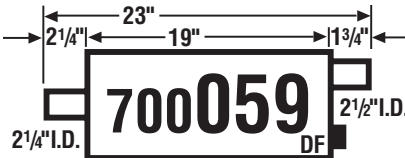
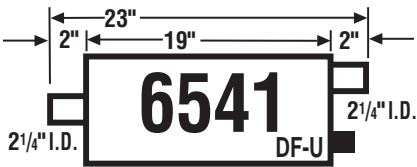
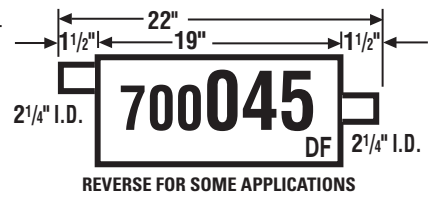
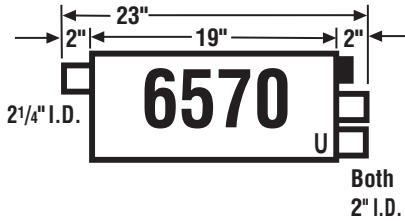

NOTE: Black area denotes welded head bracket.

DF-U - Denotes muffler used primarily as Direct Fit, but is also Universal.

U-DF - Denotes muffler used primarily as Universal, but is also Direct Fit.

DF - Direct Fit Muffler

U - Universal Muffler

HS - Denotes Heat Shield is on muffler.

MSL BY DIMENSION

4 1/16" x 10 1/2" OVALS

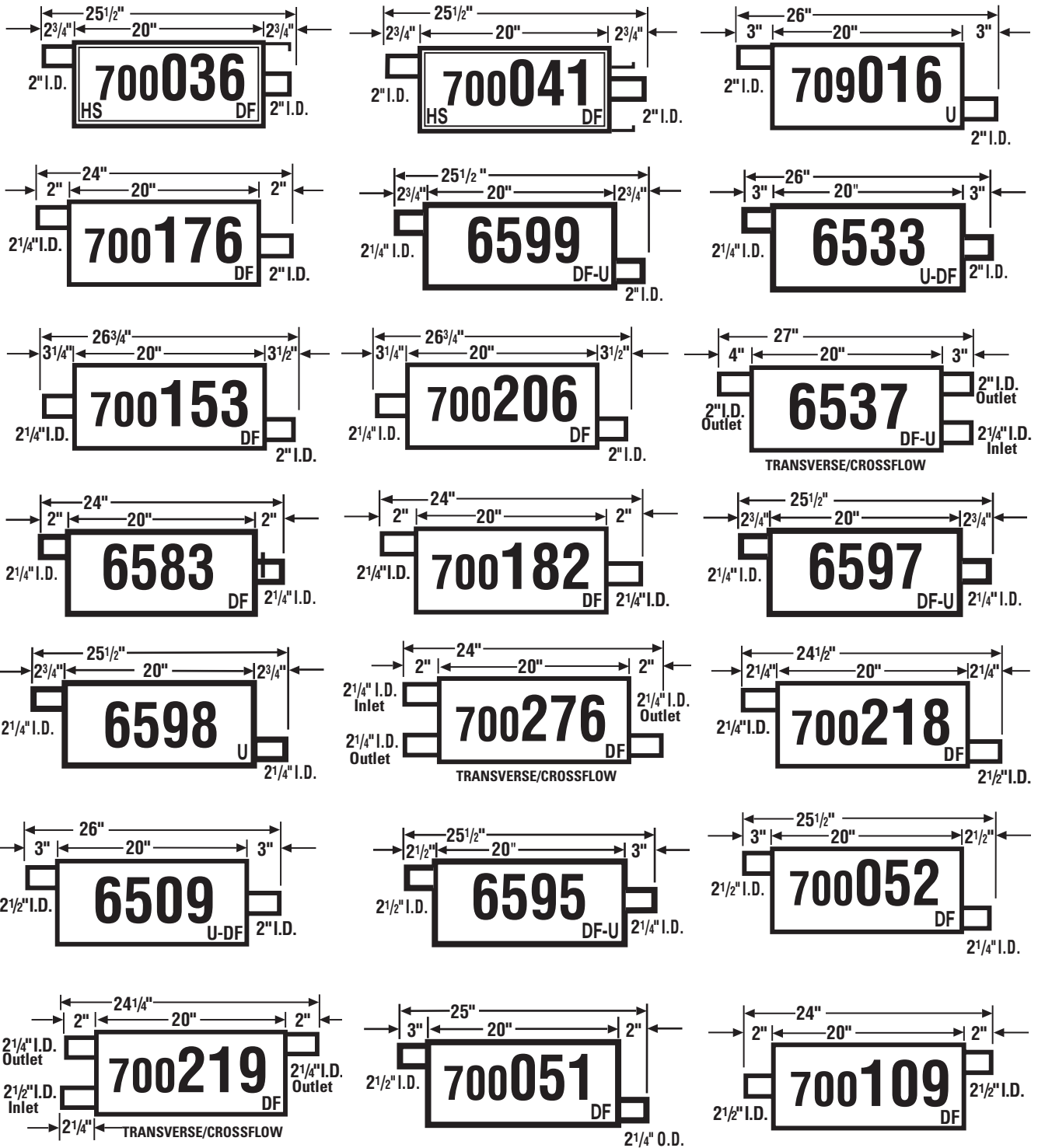

MSL BY DIMENSION

NOTE: Black area denotes welded head bracket.

DF-U - Denotes muffler used primarily as Direct Fit, but is also Universal.

DF - Direct Fit Muffler
U - Universal Muffler

U-DF - Denotes muffler used primarily as Universal, but is also Direct Fit.

HS - Denotes Heat Shield is on muffler.

UNIVERSAL SPECS

by DIMENSION

Sorted first by Cross Section, then Shell Length, then Inlet Diameter.

MAXIMUM **TMSL**

4 1/16" x 10 1/2" OVALS

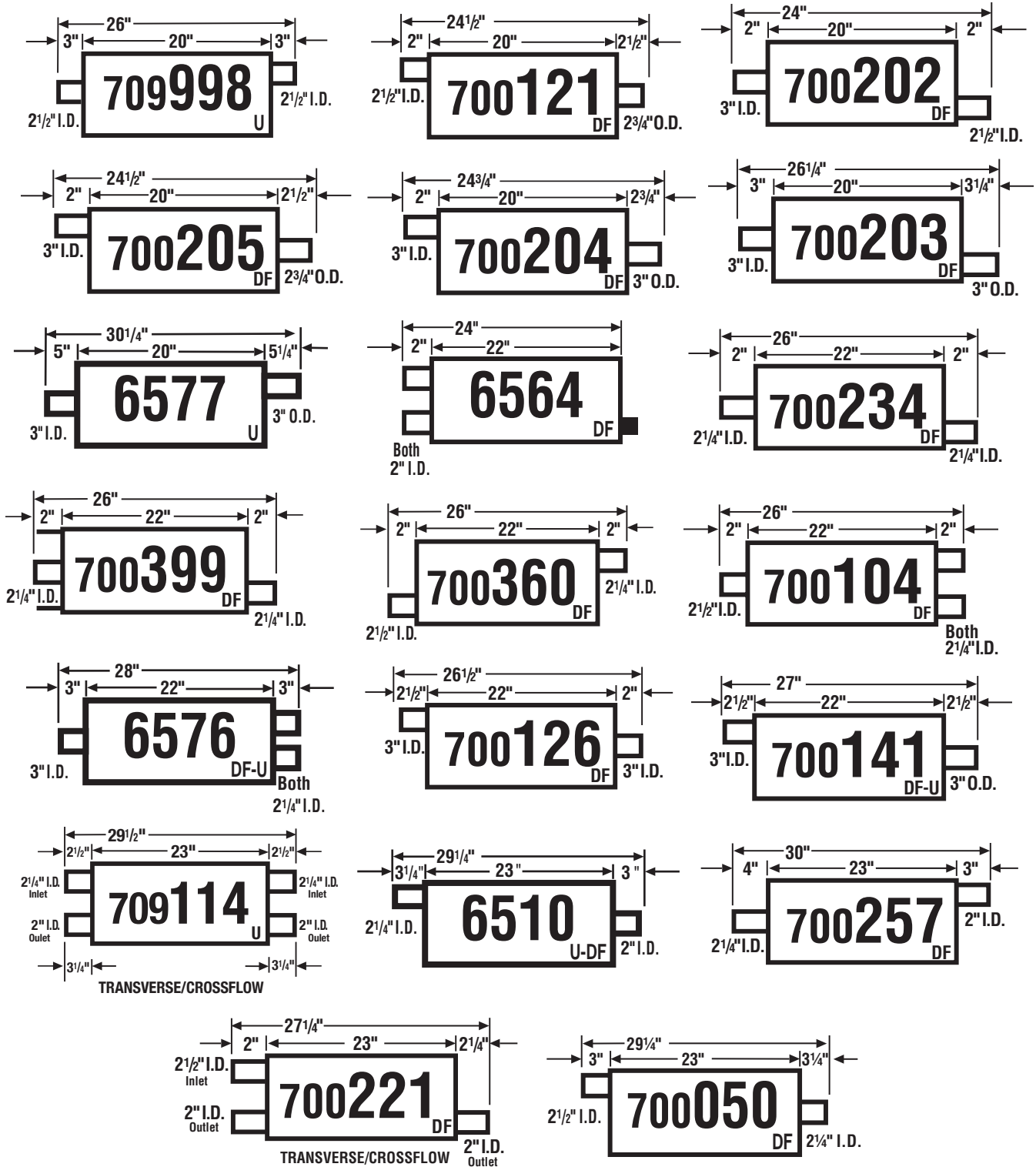

MSL BY DIMENSION

NOTE: Black area denotes welded head bracket.

DF-U - Denotes muffler used primarily as Direct Fit, but is also Universal.

U-DF - Denotes muffler used primarily as Universal, but is also Direct Fit.

DF - Direct Fit Muffler

U - Universal Muffler

HS - Denotes Heat Shield is on muffler.

4 1/16" x 10 1/2" OVALS

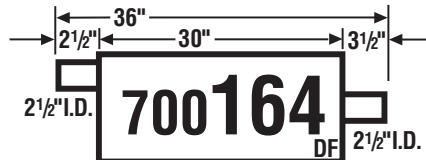
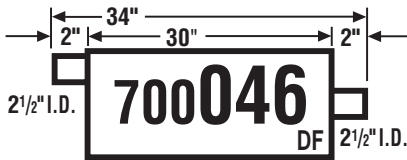
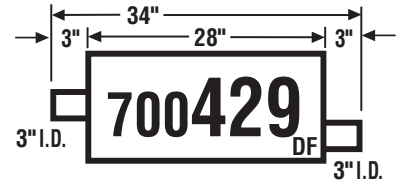
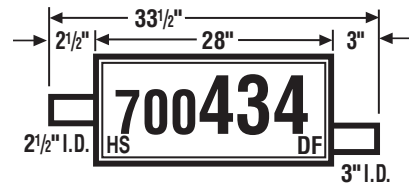
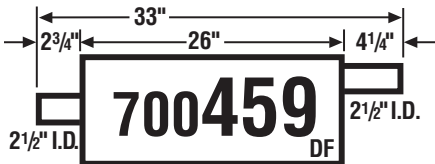
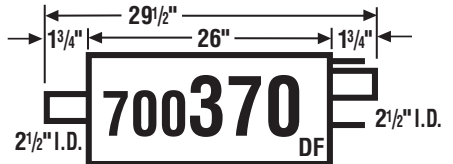
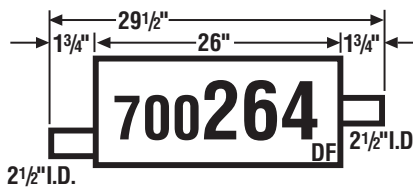
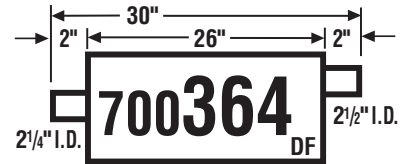
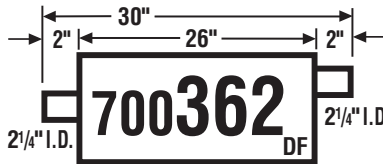

5 1/2" x 11" OVALS

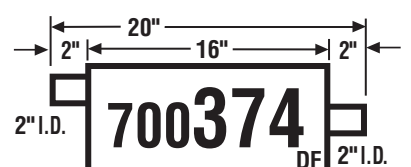
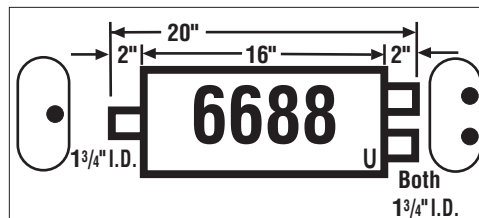
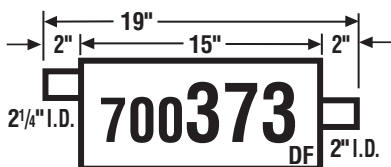
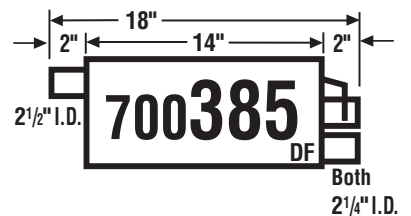
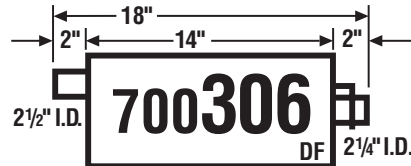
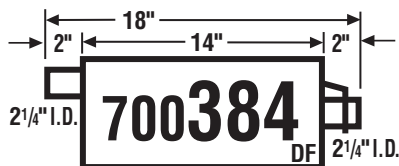
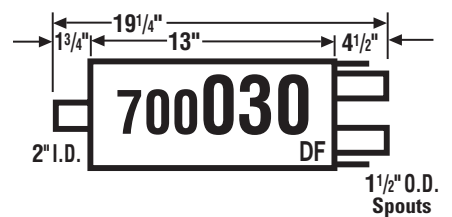
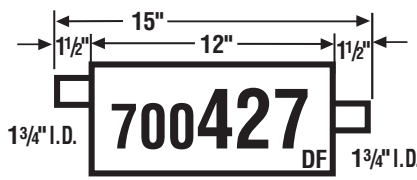
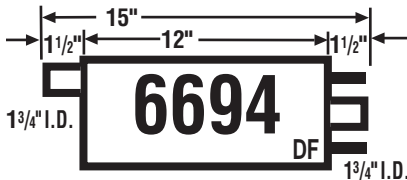

MSL BY DIMENSION

NOTE: Black area denotes welded head bracket.

DF-U - Denotes muffler used primarily as Direct Fit, but is also Universal.

U-DF - Denotes muffler used primarily as Universal, but is also Direct Fit.

DF - Direct Fit Muffler

U - Universal Muffler

HS - Denotes Heat Shield is on muffler.

UNIVERSAL SPECS

by DIMENSION

Sorted first by Cross Section, then Shell Length, then Inlet Diameter.

MAXIMUM **TMSL**®

5 1/2" x 11" OVALS

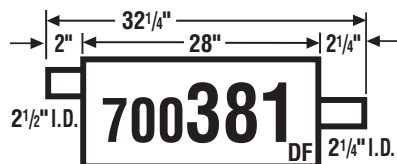
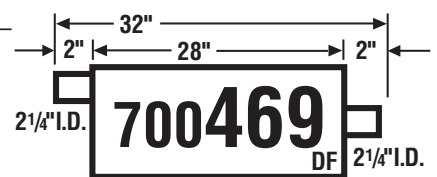
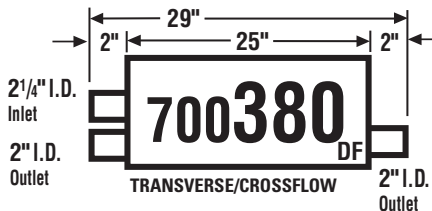
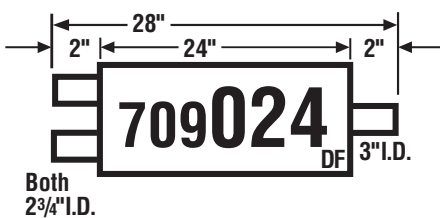
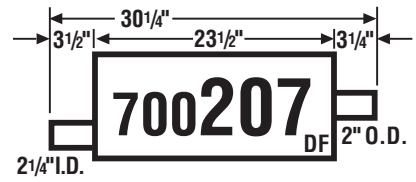
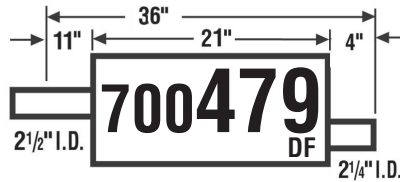
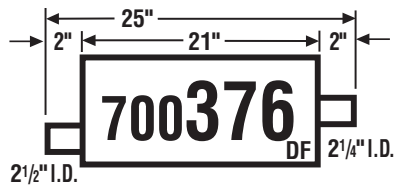
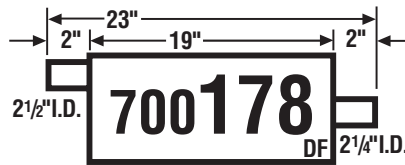
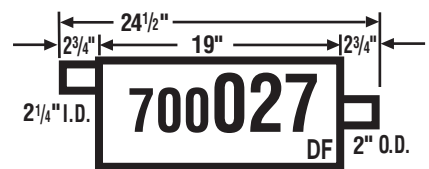
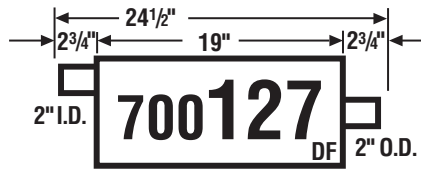
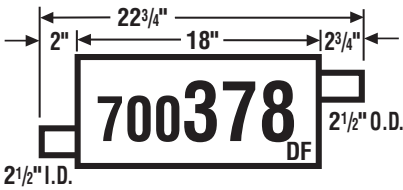
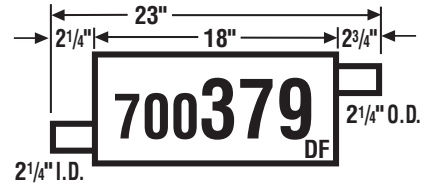
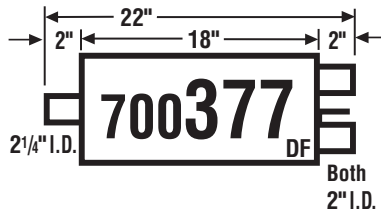
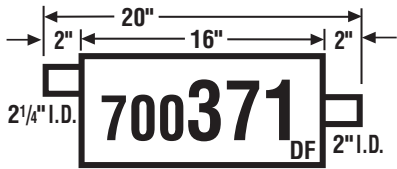

MSL BY DIMENSION

NOTE: Black area denotes welded head bracket.

DF-U - Denotes muffler used primarily as Direct Fit, but is also Universal.

U-DF - Denotes muffler used primarily as Universal, but is also Direct Fit.

DF - Direct Fit Muffler

U - Universal Muffler

HS - Denotes Heat Shield is on muffler.

7" x 9" OVALS

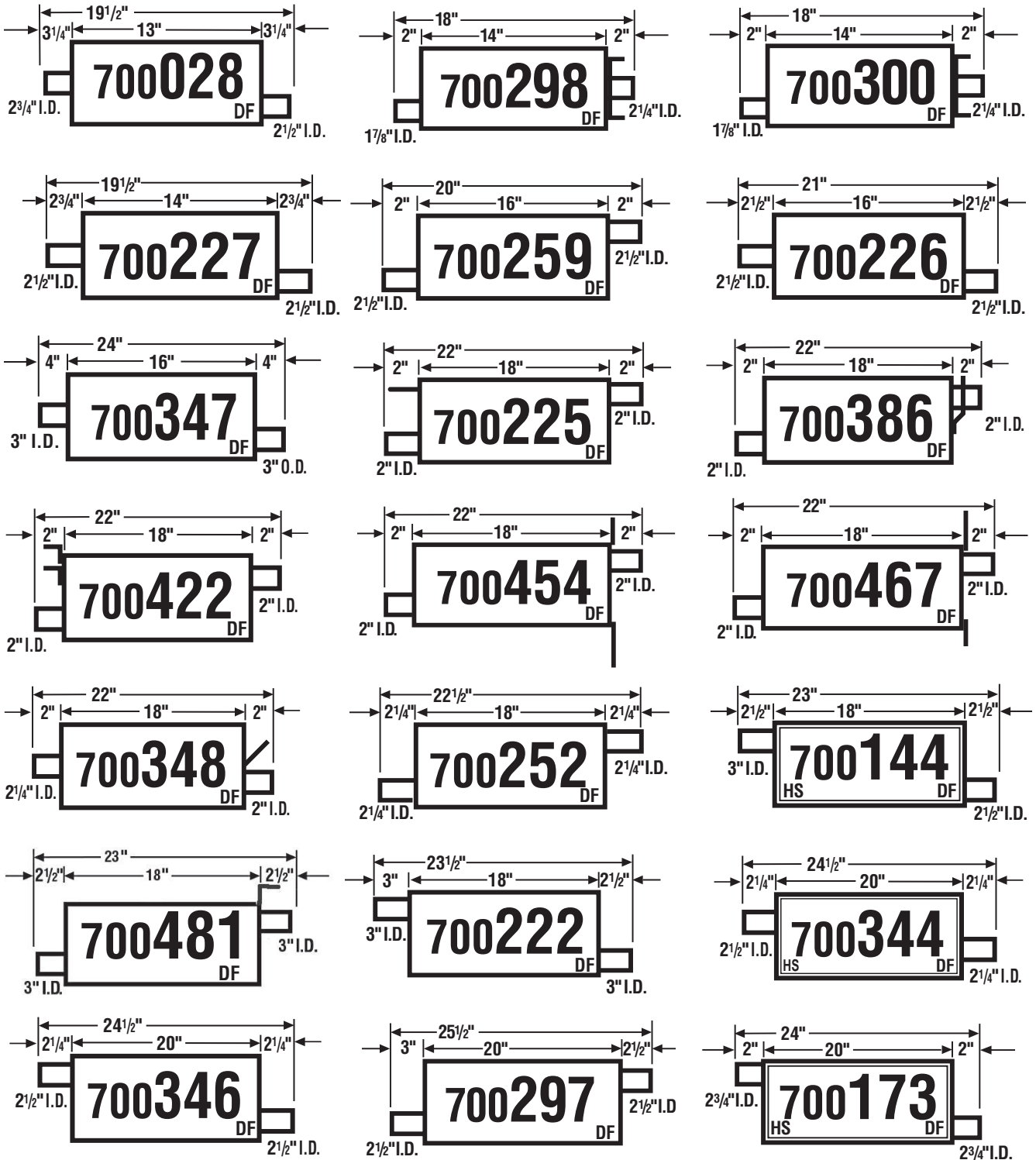

MSL BY DIMENSION

NOTE: Black area denotes welded head bracket.

DF-U - Denotes muffler used primarily as Direct Fit, but is also Universal.

U-DF - Denotes muffler used primarily as Universal, but is also Direct Fit.

DF - Direct Fit Muffler

U - Universal Muffler

HS - Denotes Heat Shield is on muffler.

UNIVERSAL SPECS

by DIMENSION

Sorted first by Cross Section, then Shell Length, then Inlet Diameter.

MAXIMUM **TMSL**[®]

7" x 9" OVALS

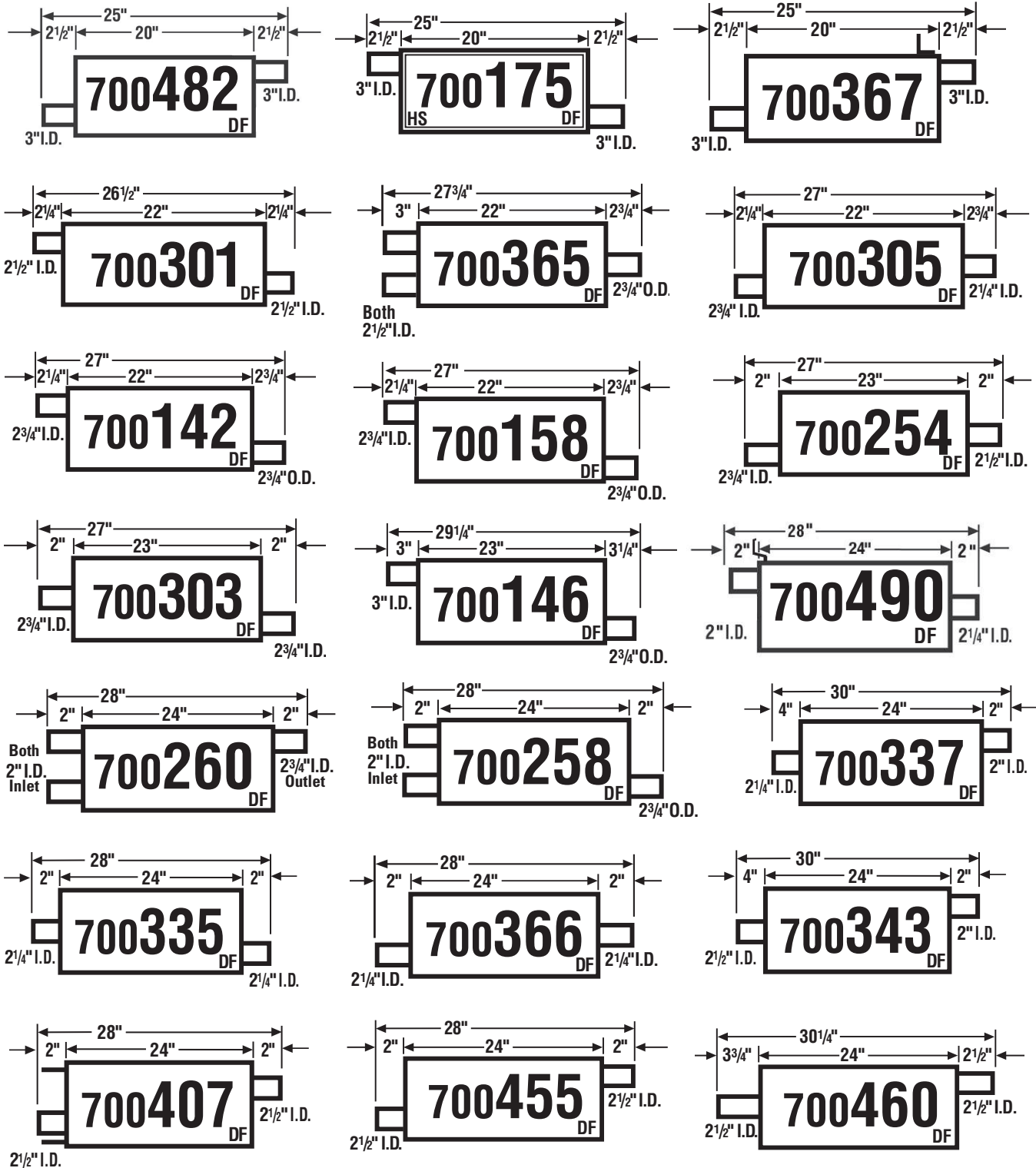

MSL BY DIMENSION

NOTE: Black area denotes welded head bracket.

DF-U - Denotes muffler used primarily as Direct Fit, but is also Universal.
 U-DF - Denotes muffler used primarily as Universal, but is also Direct Fit.

DF - Direct Fit Muffler
 U - Universal Muffler
 HS - Denotes Heat Shield is on muffler.

7" x 9" OVALS

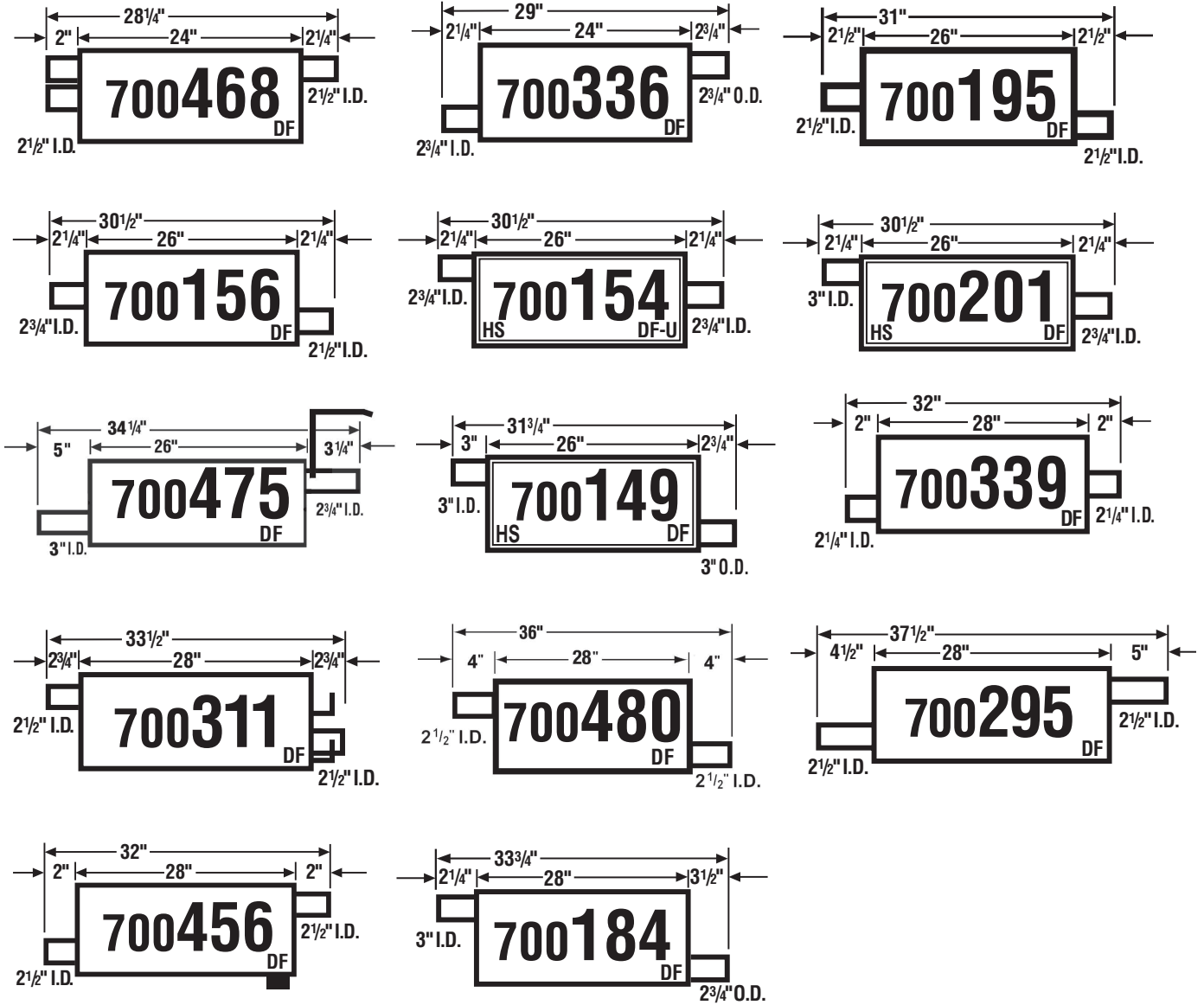

MSL BY DIMENSION

NOTE: Black area denotes welded head bracket.

DF-U - Denotes muffler used primarily as Direct Fit, but is also Universal.

U-DF - Denotes muffler used primarily as Universal, but is also Direct Fit.

DF - Direct Fit Muffler

U - Universal Muffler

HS - Denotes Heat Shield is on muffler.

UNIVERSAL SPECS

by DIMENSION

Sorted first by Cross Section, then Shell Length, then Inlet Diameter.

MAXIMUM **TMSL**®

8 1/2" x 11 1/2" OVALS

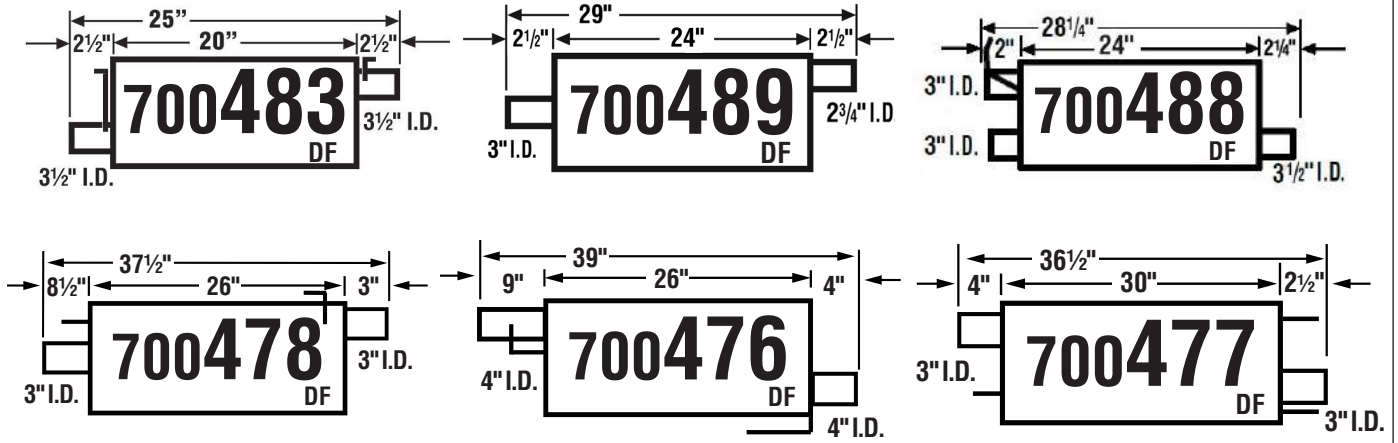

NOTE: Black area denotes welded head bracket.

DF-U - Denotes muffler used primarily as Direct Fit, but is also Universal.

U-DF - Denotes muffler used primarily as Universal, but is also Direct Fit.

DF - Direct Fit Muffler

U - Universal Muffler

HS - Denotes Heat Shield is on muffler.

MUFFLER NUMERICAL LISTING

P/N	YEAR	APPLICATION
6491		BIG MAX Turbo Muffler
6492		BIG MAX Turbo Muffler
6493		BIG MAX Turbo Muffler
6494		BIG MAX Turbo Muffler
6495		BIG MAX Turbo Muffler
6496		BIG MAX Turbo Muffler
6497		BIG MAX Turbo Muffler
6498		BIG MAX Turbo Muffler
6499		BIG MAX Turbo Muffler
6503		Universal MSL/Maximum Muffler
6504		Universal MSL/Maximum Muffler
6505	69-84 75-80	CHEV/GMC Truck C, K, P Series CHEV/GMC Truck Blazer/Jimmy
6506	70-72 70-72 71-72 70-72	CHEV/GMC Truck Caballero/Sprint CHEV Chevelle, Malibu, Monte Carlo, El Camino CHEV Full Size PONT LeMans, Tempest
6507	63-66 73-74 73-74 72-74 1966 1974 65-72 73-74	AMC Ambassador, Classic CHEV/GMC Truck Caballero/Sprint CHEV Full-Size (1973); Chevelle (73-74) FORD/MERC Fairlane, Torino, Ranchero/Montego FORD/MERC Fairlane, Comet FORD Ranchero, Torino Sta. Wgn. FORD; Full-Size PONT Full-Size, Grand Prix, LeMans, Tempest
6509	72-76	FORD/MERC Full-Size
6510	65-74	CHRY; Full-Size; Imperial (67-72)
6511	1979	FORD Truck F100/150, F200/250 Series; 138" & 155" W.B., 4.9L & 5.0L Eng.
6512	67-71	CHEV/GMC Truck Van Blazer/Jimmy (69-74); C, K, P Series (69-74); G Series (67-74)
6516		Universal MSL/Maximum Muffler
6519		BIG MAX Turbo Muffler
6520	54-64	CHEV Full-Size
6521		Universal MSL/Maximum Muffler
6525		Universal MSL/Maximum Muffler
6526		Universal MSL/Maximum Muffler
6527		Universal MSL/Maximum Muffler
6529		Universal MSL/Maximum Muffler
6530	88-91	ISUZU Truck Pickups, Trooper, Trooper II
6532	71-74	CAD; 8 Cyl., All Models (Front)
6533	67-78	FORD Full-Size LTD II, Ranchero, To- rino, Torino Elite; Thunderbird (74-78); Falcon
6534		BIG MAX Turbo Muffler

P/N	YEAR	APPLICATION
6536	75-80	BUICK/CHEV/OLDS/PONT Skyhawk/ Monza/Starfire, Sunbird (76-80); Astre (1975)
6537	75-79 75-81	BUICK/CHEV/OLDS/PONT Apollo, Skylark/Chevy II-Nova (75-78)/Omega/ Ventura II, Phoenix CHEV/PONT Camaro, Firebird
6538	80-85 80-83 80-86 80-85 80-81 82-86	BUICK Full-Size CAD; Full-Size CHEV Full-Size (80-84); Camaro (82-86) OLDS; Full-Size PONT Catalina, Bonneville, Safari Sta. Wag. PONT Firebird, Parisienne (1984)
6539		Universal MSL/Maximum Muffler
6540	78-87 78-84	BUICK/CHEV/OLDS/PONT Regal(78-87); Century (78-81)/Malibu, Monte Carlo, El Camino/Cutlass/Bonneville (82-86); Grand Prix (78-87); LeMans, Grand AM (78-81) CHEV/GMC Truck Caballero/Sprint
6541#	79-85	BUICK/CAD/OLDS; Eldorado/Seville (80-85); Riviera/Toronado (79-85)
6542		Universal MSL/Maximum Muffler
6543	77-90 84-96 77-90	BUICK/CAD/OLDS; Full-Size; Riviera (77-78); Cadillac (79-82) (1985) BUICK/CHEV/OLDS/PONT Century/ Cutlass Ciera (84-96); 6000 (85-91); Celebrity (85-90) CHEV/PONT Full-Size
6544#		Universal MSL/Maximum Muffler
6550#	81-88	CHRY/DODGE/PLYM New Yorker (83- 87); LeBaron, Town & Country (82-86); 600/Caravelle (81-88); Aries/Reliant (81-86); 400 (81-85)
6554#	83-89 79-82 80-89	FORD/MERC Crown Victoria/Grand Marquis FORD/MERC LTD/Marquis LINC; Mark VI (80-83); Continental (80- 81); Town Car (81-89)
6555	77-81	CHEV/PONT Camaro, Z28/Firebird, Trans Am (78-81)
6557	80-87	CHEV/GMC Truck Blazer/Jimmy; C, G, K, P Series
6558	84-94	FORD/MERC Tempo/Topaz
6559		Universal MSL/Maximum Muffler
6560#	84-94	BUICK/CAD/CHEV/OLDS/PONT Sky- hawk (84-89) (85-87)/Cimarron (84-88)/ Cavalier (84-94)/ Grand AM (85-91)/ Sunbird (84-94)
6562#		Universal MSL/Maximum Muffler
6563#	83-89	FORD/MERC Mustang/Capri (83-86)

Muffler includes bracket.

MUFFLER NUMERICAL LISTING

MAXIMUM® **MSL**®

P/N	YEAR	APPLICATION
6564#	84-86	BUICK/CHEV/OLDS/PONT Century/Celebrity/Cutlass Ciera/6000 (All Sta. Wagons)
6565#		Universal MSL/Maximum Muffler
6567#	85-90	FORD/MERC Escort (85-90); EXP (86-88)/Lynx (85-87)
6569#	82-84	DODGE/PLYM Truck Rampage/Scamp
	83-87	DODGE/PLYM Charger (FWD)/Turismo
	81-90	DODGE/PLYM Omni/Horizon
6570#		Universal MSL/Maximum Muffler
6571#	85-92	FORD Truck Ranger
6573#	82-87	BUICK/CHEV/OLDS/PONT Century/Celebrity/Cutlass Ciera/6000
6575#	84-91	BUICK/CHEV/OLDS/PONT Skyhawk (84-89); Skylark (86-88); Somerset, Somerset Regal (85-87)/Cavalier (84-90)/Calais (85-88); Firenza (84-88)/Grand Am (85-87)/J2000, Sunbird (84-91)
6576	91-95	CHEV/GMC Truck C, K Series
6577		Universal MSL/Maximum Muffler
6578	86-91	BUICK/CAD/OLDS/PONT Electra, LeSabre, Riviera/DeVille, Fleetwood; Eldorado/Seville (86-87); 88, 98, Toronado/Bonneville (88-91)
6579#	88-93	BUICK/CHEV/OLDS/PONT Regal/ Lumina (90-93)/Cutlass Supreme/ Grand Prix
6580	75-79	CAD Seville
6582#		Universal MSL/Maximum Muffler
6583#	85-91	CHEV/GMC; Astro/Safari Van
6584	88-92	CHEV/PONT Camaro/Firebird
6586	86-89	FORD Truck Bronco II
6587#	87-88	FORD/MERC Thunderbird/Cougar
6588#	87-92	CHEV Beretta, Corsica
	87-91	PONT Tempest (Canada)
6590	82-91	CHEV/GMC Truck S10/S15, T10/T15; Blazer/Jimmy (83-89)
6591#	84-92	BUICK Century
	86-89	CHEV Celebrity
	84-92	OLDS Cutlass Ciera
	86-91	PONT 6000
6592#	87-97	FORD Truck Bronco, F150, F250, F350
6595	1982	CHEV/GMC; Van G Series
	80-89	DODGE/PLYM Truck AD, AW, PD, PW Series
	75-76	FORD/MERC Galaxie, LTD/Marquis
6595	75-77	GM; Century, LeSabre, Electra, Riviera, Bel Air, Impala, Caprice, Cutlass, Delta 88, 98, LeMans, Catalina, Bonneville, Grand Prix
	1978	OLDS; Toronado

Muffler includes bracket.

P/N	YEAR	APPLICATION
6596		Universal MSL/Maximum Muffler
6597	94-96	BUICK/OLDS; Park Avenue, 98
	67-80	CHRY/DODGE/PLYM; Full-Size, Cordoba
	91-92	FORD Truck Explorer
	77-78	FORD/MERC LTD/Marquis
	73-77	GM; LeSabre, Centurion, Electra, Caprice, Impala, Toronado, Delta 88, 98, Catalina, Bonneville, Grand Prix
	1995	CAD Deville
6598		Universal MSL/Maximum Muffler
6599	75-78	CHEV/GMC; Van G Series
	65-73	GM; Full-Size, Intermediate
6651		Universal MSL/Maximum Muffler
6652		Universal MSL/Maximum Muffler
6653		Universal MSL/Maximum Muffler
6654		Universal MSL/Maximum Muffler
6655		Universal MSL/Maximum Muffler
6658		Universal MSL/Maximum Muffler
6669	74-82	NISSAN 210, B210
6672	75-82	CHEV Truck Luv
	81-87	ISUZU Truck Pickup
	84-85	ISUZU Truck Trooper II
	84-95	TOYOTA Truck 4-Runner
	79-95	TOYOTA Truck Pickup, Cab & Chassis
6677		Universal MSL/Maximum Muffler
6678#	84-93	VOLVO; 240 DL, GL
	80-85	VOLVO; 2, 4-Dr. Sedan, Sta. Wag.
	75-80	VOLVO; 240, 260 Series
6685	86-89	ACURA Integra
	86-87	HONDA Civic, Si Hatchback
6688		Universal MSL/Maximum Muffler
6689#	90-94	SUBARU Loyale
	85-89	SUBARU 3-Dr. Coupe, 4-Dr. Sedan, Sta. Wag.
6691#	87-91	TOYOTA Camry
6694#	90-92	GEO Prizm
	88-92	TOYOTA Corolla
6695#	86-97	NISSAN Truck D21 (Hardbody) Pickup
690003		BIG MAX Turbo Muffler
690008		BIG MAX Turbo Muffler
690500		BIG MAX Turbo Muffler
690501		BIG MAX Turbo Muffler
690502		BIG MAX Turbo Muffler
690503		BIG MAX Turbo Muffler
690510		BIG MAX Turbo Muffler
690511		BIG MAX Turbo Muffler
690512		BIG MAX Turbo Muffler
690513		BIG MAX Turbo Muffler
690514		BIG MAX Turbo Muffler
700000#	87-96	FORD Van Econoline E150/250/350

MSL NUMERICAL LISTING

P/N	YEAR	APPLICATION
700001#	80-86	FORD Truck F Series; Bronco (80-84)
700002#	86-89	FORD Van Aerostar
700003#	89-94	GEO Metro; CHEV Sprint; PONT Firefly (89-91)
	89-94	SUZUKI Swift
700006#	83-89	FORD Crown Victoria
	80-82	FORD LTD
	82-89	LINC Town Car
	80-89	MERC Grand Marquis
700010	86-93	MAZDA Truck B2200; B2600 (87-88) Pickup
700012#	88-93	FORD Festiva
700013#	90-91	FORD Crown Victoria Sedan, Sta. Wag. (Right Side)
	90-91	MERC Grand Marquis Sedan, Sta. Wag. (Right Side)
700016#	84-94	FORD/MERC Tempo/Topaz
700017#	86-89	HONDA Accord, 2-Dr. Hatchback, Coupe; 4-Dr. Sedan
700018#	90-93	HONDA Accord DX, LX, 2-Dr. Coupe, 4-Dr. Sedan
700019#	90-93	HONDA Accord EX, SE (1991 & 1993) 2-Dr. Coupe, 4-Dr. Sedan
700020	88-04	CHEV/GMC Truck T10/T15 Pickup
	88-95	CHEV/GMC Truck S10/S15 Pickup
	88-91	CHEV/GMC Truck S10/S15 Blazer/Jimmy
	1990	DODGE/PLYM Truck Dakota
	88-04	GMC Sonoma
	98-99	ISUZU Truck Hombre
	1991	OLDS Truck Bravada
700024#	89-95	GEO Truck Tracker
	89-95	SUZUKI Truck Sidekick
700026#	90-94	CHRY LeBaron 4-Dr. Sedan
	89-95	DODGE Spirit
	89-95	PLYM Acclaim
700027	91-95	CHRY Van Town & Country, exc. AWD
	91-95	DODGE/PLYM Van Caravan/Voyager
700028	92-93	DODGE/PLYM Truck Dakota, D150/250, W150/250, Ramcharger
700030#	89-94	NISSAN 240 SX (Rear Muffler)
700031#	84-89	NISSAN 300ZX, All Models
700034	93-03	FORD Truck Ranger
	94-04	MAZDA Truck B2300, B2500, B3000, B4000, Pickup
700036#	93-94	FORD Truck Explorer 4-Dr
700037#	92-97	FORD/LINC/MERC Crown Victoria/Town Car/Grand Marquis; Single Exh., Dual Exh. (Right Side)

P/N	YEAR	APPLICATION
700038#	92-97	FORD/LINC/MERC Crown Victoria/Town Car/Grand Marquis; Dual Exh. (Left Side)
700039#	95-03	FORD Truck Ranger
	95-04	MAZDA Truck B2300
	98-04	MAZDA Truck B2500
	95-03	MAZDA Truck B3000, B4000
700040#	95-00	FORD Truck Explorer 2-Dr
700041#	95-00	FORD Truck Explorer 4-Dr
700044	90-97	FORD Van Aerostar
700045	96-01	JEEP Truck Cherokee
	86-92	JEEP Truck Wagoneer, Comanche, Cherokee
700046	85-97	FORD Truck F250/350/450, Commerical Stripped Chassis, Motor Home
700050	75-78	CHRY Chrysler Newport, New Yorker, Imperial, Town & Country
	88-89	DODGE/PLYM Truck D100/150/250, W100/150
	79-89	DODGE/PLYM Truck Series D, W, AD, AW/PD, PW, Ramcharger/Trail Duster
	75-87	DODGE/PLYM Vans Series B, C, P, CB, MB, Wagon
700051	88-93	CHEV/GMC Truck C1500/2500, K1500/2500
	83-93	CHEV/GMC Van G20/2500, G30/3500
	82-90	CHEV/GMC Truck P30/3500
	81-85	CHEV/GMC Truck Suburban
	1979	CHEV/GMC Truck Suburban
	85-87	CHEV/GMC Truck C10/1500, C20/2500, K10/1500, R10/1500, R20/2500, V10/1500
	75-85	CHEV/GMC Truck Series C, K
	78-84	CHEV/GMC Truck C Series, K30/3500
	80-82	CHEV/GMC Truck Blazer/Jimmy
	75-82	CHEV/GMC Truck C10/1500, C30/3500, K Series
700052	71-73	CHEV Full-Size
	75-94	CHEV/GMC Van G Series
700053	82-89	CHRY New Yorker, Fifth Avenue
	80-83	CHRY Cordoba, Imperial (81-83)
	79-81	CHRY Newport (79-80); New Yorker (1979); LeBaron, Town & Country (79-80)
700053	79-89	DODGE Diplomat, Mirada (80-89); St. Regis (1979)
	76-80	DODGE Aspen (exc. 1978)
	82-89	PLYM Gran Fury
	76-80	PLYM Volare (exc. 1978)
700054	77-90	BUICK LeSabre Estate Wagon
	86-90	CHEV Caprice Sta. Wag.
	81-85	CHEV Caprice, Impala Sta. Wag.

Muffler includes bracket.

MUFFLER NUMERICAL LISTING

MAXIMUM® **TMSL**®

P/N	YEAR	APPLICATION	
700054 (CON'T)	1993	CHRY Imperial, New Yorker, Fifth Avenue	
	77-90	OLDS Delta 88 (77-79), Custom Cruiser (80-90)	
	87-89	PONT Safari Sta. Wag.	
	83-86	PONT Parisienne Sta. Wag.	
	77-81	PONT Catalina, Bonneville, Sta. Wag., Safari Sta. Wag. (1981)	
700056	83-90	BUICK Estate Wagon	
	80-85	BUICK Full-Size Models	
	81-84	BUICK Electra, Park Avenue (exc. Estate Wagon)	
	77-81	BUICK LeSabre	
	77-79	BUICK Electra, Riviera	
	81-90	CAD Brougham (86-90); Fleetwood Brougham	
	81-85	CAD Fleetwood, Deville	
	77-82	CAD Full-Size Models	
	81-90	CHEV Caprice, Impala (81-85)	
	86-90	OLDS Custom Cruiser	
	77-85	OLDS Delta 88, 98	
	83-89	PONT Parisienne, Safari Sta. Wag. (87-89)	
	77-81	PONT Catalina, Bonneville	
700057	78-87	BUICK Century (78-87), Regal	
	78-88	CHEV Chevelle, Monte Carlo	
	78-87	CHEV El Camino, Malibu	
	79-87	GMC Caballero	
	78-88	OLDS Cutlass, Cutlass Cruiser Sta. Wag. (80-81)	
	79-87	PONT Bonneville (82-87); Grand Prix	
	79-81	PONT LeMans, Grand AM	
700058#	84-93	VOLVO 240 DL, GL (exc. Turbo) (Front Muffler)	
	80-85	VOLVO Sedan, Sta. Wag. (Front Muffler)	
	80-83	VOLVO DL, Sedan, Sta. Wag. (exc. Turbo) (Front Muffler)	
	77-82	VOLVO Series 242, 244, 245, 262, 264, 265 (Front Muffler)	
700059#	79-85	CAD Eldorado, Seville (80-85)	
700060#	86-91	BUICK Skylark	
	84-89	BUICK Skyhawk	
	85-87	BUICK Somerset, Somerset Regal	
	84-88	CAD/OLDS Cimarron/Firenza	
	84-94	CHEV Cavalier	
	85-91	OLDS Calais	
	85-91	PONT Grand AM	
	84-94	PONT Sunbird	
	700061#	80-81	BUICK Riviera
		79-85	CAD Eldorado, Seville
79-81		OLDS Toronado	

P/N	YEAR	APPLICATION
700062	1988	DODGE/PLYM Truck D100/150
	79-87	DODGE/PLYM Truck/Van Series B, D, W, PB, CB300/350, MB300, PD100, PW100
	79-80	DODGE/PLYM Truck AD100, AW100
	95-99	DODGE/PLYM Neon
700065	80-94	CHEV/GMC Van G Series
	82-88	CHEV/GMC P30/P3500 Series
700067	82-90	CHRY LeBaron, New Yorker (83-87), "E" Class (83-84) Town & Country (82-88)
	89-90	DODGE Spirit (exc. Turbo)
	82-88	DODGE 400 (82-83), 600, Aries, Aries America
	89-90	PLYM Acclaim (exc. Turbo)
	83-88	PLYM Caravelle (85-88), Reliant, Reliant America, Horizon (83-90)
	85-90	DODGE/PLYM Omni/Horizon (Canada)
700068	84-86	JEEP Truck CJ7, CJ8, Scrambler
	81-83	JEEP Truck CJ5, CJ7, CJ8, All Models, (1983), Calif. Models (81-82)
700069	85-90	CHEV/PONT Camaro/Firebird
	82-87	CHEV/PONT Camaro, Berlinetta (exc. Z28)/Firebird (exc. Trans AM)
700074	83-86	FORD Truck Ranger
700075	84-87	JEEP Truck Wagoneer, Cherokee
	1986	JEEP Truck Commanche
	87-96	DODGE Dakota
700076#	84-86	FORD Van E150/250/350, Econoline
700081#	85-88	CHEV Nova
	84-87	TOYOTA Corolla (exc. Diesel)
700082	84-87	HONDA Civic Hatchback, CRX (85-87)
700085	91-95	VOLVO 940; 940 GLE (1991)
	85-92	VOLVO 740
	83-90	VOLVO 760, 780 (86-87)
700087	91-93	BUICK Roadmaster (Front Muffler)
	90-93	CAD Brougham, Fleetwood Brougham (Front Muffler)
	85-93	CHEV Caprice, Impala (Front Muffler)
	91-92	OLDS Custom Cruiser (Front Muffler)
	85-86	PONT Parisienne (Front Muffler)
700088#	90-92	CAD Brougham (Rear Muffler)
	85-89	CHEV Caprice, Impala Sedan (Rear Muffler)
	85-86	Pont. Parisienne Sedan (Rear Muffler)
700090	83-88	CHEV Monte Carlo SS (Both Sides)
700093	85-92	VW Golf, Jetta (Rear)
700096#	86-93	FORD Mustang, GT, LX (Left Side)
	1986	MERC Capri (Left Side)
700097#	86-93	FORD Mustang, GT, LX (Right Side)
	1986	MERC Capri Dual Exh. (Right Side)

MSL NUMERICAL LISTING

P/N	YEAR	APPLICATION
700098	86-95	FORD Taurus, Taurus SHO (86-95), Police Car (91-92), Linc. Continental (88-94), Single and Dual Exh. (Both Sides)
	86-95	MERC Sable Sedan, Sta. Wag.
	03-08	PONT Truck Vibe
700099#	87-96	FORD Truck F150, 250 (87-93)
	87-91	FORD Truck Bronco (exc. Chassis Cab)
	84-86	FORD Truck Bronco
700100	87-90	JEEP Truck Wrangler
700101#	89-90	CHRY LeBaron Coupe, Convertible (exc. Turbo)
	87-88	CHRY/CHRY Van LeBaron/Town & Country
	87-88	DODGE/PLYM Aries, Aries America/Reliant, Reliant America
700103#	87-94	DODGE/PLYM Shadow, Shadow America/Sundance, Sundance America (exc. Turbo)
	1992	PLYM Duster
700104	90-93	CHEV/GMC Truck C1500/2500, K1500/2500
	1990	CHEV/GMC Truck C2500, K2500
	88-90	CHEV/GMC Truck Series C,K All Models
700106#	90-93	CHRY New Yorker Landau, Salon, Fifth Avenue, Imperial
	88-89	CHRY New Yorker
	88-93	DODGE Dynasty
700108#	87-92	FORD Truck Ranger
700109	87-89	CHEV/GMC Truck Blazer/Jimmy
	87-88	CHEV/GMC Truck V10/1500, Suburban
	1987	CHEV/GMC Truck R20/2500
700110	88-91	HONDA Civic Hatchback, STD, Sedan, DX, LX, Sta. Wag., Wagon, CRX HF, CRX DX
700114	87-92	JEEP Truck Wrangler
700119#	90-95	CHRY LeBaron Coupe, Convertible
700120	1992	DODGE/PLYM Van B250/350
	89-91	DODGE/PLYM Van B150/250/350
700121	90-91	CHEV/GMC Truck Blazer/Jimmy
	88-91	CHEV/GMC Truck V10/1500, V20/2500, Suburban
	88-90	CHEV/GMC Truck R10/1500, R20/2500
700125#	86-95	SUZUKI Truck Samurai
700126	1991	CHEV/GMC Vans G Series
	88-95	CHEV/GMC C/K Series
700127	91-95	DODGE/PLYM Vans Caravan/Voyager
700129#	91-94	NISSAN Sentra
700131#	89-94	HYUNDAI Sonata
700132	90-93	ACURA Integra
700140#	90-91	HONDA Prelude Si
	88-89	HONDA Prelude w/ Fuel Injection

P/N	YEAR	APPLICATION
700141	87-96	CHEV/GMC Truck P30/3500
	87-89	CHEV/GMC Van G30/3500, R20/2500, R30/3500, V20/2500, V30/3500
700142	94-95	CHEV/GMC C1500/2500, K1500/2500
700143#	94-96	BUICK/OLDS Century/Cutlass Ciera, (exc. Sta. Wag.)
700144	92-95	CHEV/GMC Van Astro/Safari
700145#	1993	BUICK/OLDS Century, Cutlass Ciera, Sedan
700146	92-96	CHEV/GMC Van G Series
700147#	92-00	HONDA Civic EX, Coupe (93-00), Sedan (92-00)
	96-97	HONDA Civic, All Models exc. EX
700149	92-93	CHEV/GMC Truck C1500/2500, K1500/2500, Suburban
700150	95-99	CHEV/GMC Truck Blazer/Jimmy, 4-Dr.
	96-99	OLDS Bravada
700151#	93-97	FORD Probe
700152	95-04	TOYOTA Tacoma Pickup
	88-95	TOYOTA Truck Pickup, Cab & Chassis, 4-Runner
	93-97	TOYOTA T100 Pickup
700153	93-98	JEEP Truck Grand Cherokee, Grand Wagoneer, 2 & 4 WD
700154	94-95	CHEV/GMC Truck C1500/2500, K1500/2500, Suburban
700155#	93-97	MAZDA MX-6, 626
700156	92-94	DODGE/PLYM Truck B150/250
700158	94-95	CHEV/GMC Truck C1500/2500, K1500/2500
700159#	91-03	FORD/MERC Escort/Tracer
700160	91-02	SATURN Sedan, Coupe, Sta. Wag.
700162#	92-94	BUICK/OLDS/PONT Skylark/Achieva/Grand AM
	93-94	CHEV Beretta, Corsica, (exc. Beretta) GT/GTZ, Z26
700164	81-94	FORD Truck E250/350
	1997	FORD Truck F450, 7.3L
700166	1992	CHEV/GMC Van Astro/Safari
700167#	93-97	NISSAN Altima
700169#	92-00	HONDA Civic Hatchback
700171#	94-96	BUICK/CAD/CHEV Roadmaster/ Fleetwood Brougham RWD/Caprice, Dual Exh. (Right Front Muffler)
700172#	94-96	BUICK/CAD/CHEV Roadmaster/ Fleetwood Brougham RWD/Caprice, Dual Exh. (Left Front Muffler)
700173	94-95	CHEV/GMC Truck Tahoe/Yukon
700175	92-93	CHEV/GMC Truck Blazer/Yukon
700176	92-94	CHEV/GMC Truck S10/S15 Pickup
700177	91-95	VOLVO 940, 940 GLE (91) (exc. Turbo) (Rear Muffler)
	88-92	VOLVO 740, (exc. Turbo) 760, 780 (88-91) (Rear Muffler)

Muffler includes bracket.

MUFFLER NUMERICAL LISTING

MAXIMUM **TMSL**[®]

P/N	YEAR	APPLICATION
700178	92-94	CHEV/GMC Truck Blazer/Jimmy S10/S15, T10/T15, 2 WD/4 WD
	92-94	OLDS Truck Bravada 4 WD
700179#	98-01	CHEV Metro
	95-97	GEO Metro
	95-01	PONT Firefly (Canada)
700181#	95-96	SUZUKI Swift
	94-97	HONDA Accord DX, LX
700182	95-03	CHEV/GMC S10/S15 Pickup
	96-00	ISUZU Hombre
700183#	93-02	VW Cabriolet (95-02), Golf (93-97), Jetta (93-99) (Rear)
700184	1995	CHEV/GMC Van G Series
700185	95-05	BUICK/CHEV/OLDS/PONT Skylark, Achieva, Grand Am (95-98); Beretta/Corsica (95-96), Cavalier/Sunfire (95-05)
	95-99	CAD Deville, Eldorado, Dual Ex. (Both Sides)
	95-97	CAD Seville, Dual Ex. (Both Sides)
700186#	95-98	MAZDA 323 Protégé
700187	95-99	CHEV/GMC Truck Blazer/Jimmy S10/S15, T10/T15, 2-Dr.
700188#	97-99	ACURA CL
	94-97	HONDA Accord Ex, LX, 2-Dr. Coupe, 4-Dr. Sedan
700190	93-96	JEEP Truck Wrangler
700191#	95-99	DODGE/PLYM Neon
700192#	90-92	OLDS/PONT Cutlass Supreme/Grand Prix, (Right Side)
700193#	90-92	OLDS/PONT Cutlass Supreme/Grand Prix, (Left Side)
700194#	92-96	FORD Truck E150/E250
700195	94-97	DODGE/PLYM Truck B150/B250
700196	91-93	BUICK/CHEV/OLDS Sta. Wag. Roadmaster/Caprice/Custom Cruiser (91-92)
	85-86	CHEV/PONT Caprice, Impala Parisienne, Sta. Wag.
700197	92-93	BUICK/OLDS/PONT LeSabre/88/ Bonneville SE
700198#	92-94	OLDS/PONT Achieva/Grand Am,(Left Side)
700199#	92-94	OLDS/PONT Achieva/Grand Am,(Right Side)
700201	94-95	CHEV/GMC Truck C1500/2500,K1500/2500, Suburban, 2 Or 4 WD, w/ 3" Inlet
700202	87-88	CHEV/GMC Truck V10/V1500, V20/V2500, Suburban, 4 WD, w/ 3" Inlet
700203	87-88	CHEV/GMC Truck R10/1500, R20/2500, Suburban, 2 WD, w/ 3" Inlet
700204	87-90	CHEV/GMC Van G Series, w/ 3" Inlet

P/N	YEAR	APPLICATION
700205	88-91	CHEV/GMC Truck V10/1500, V20/2500, Suburban, 4 WD, w/ 3" Inlet
	88-90	CHEV/GMC Truck R10/1500, R20/2500, Suburban, 2 WD, w/ 3" Inlet
700206	92-98	JEEP Truck Grand Cherokee, 2 & 4 WD
	93-95	JEEP Truck Cherokee, 2 & 4 WD
700207	91-95	CHRY Truck Town & Country
	91-95	DODGE/PLYM Truck Grand Caravan, Grand Caravan C/V, Grand Voyager
700211#	93-97	GEO Prizm, Prizm LSI
	93-97	TOYOTA Corolla
700215#	1993	OLDS Cutlass Supreme, Dual Ex. (Right)
	93-96	PONT Grand Prix, Dual Ex. (Right)
700216#	1993	OLDS Cutlass Supreme, Dual Ex. (Left)
	93-96	PONT Grand Prix, Dual Ex. (Left)
700217#	93-95	HONDA Civic Del Sol S
700218	93-02	CHEV Camaro
	93-02	PONT Firebird
700219	93-02	CHEV Camaro
	93-02	PONT Firebird
700221	1992	CAD Eldorado, Seville
700222	90-95	CHEV/GMC Truck C3500
	90-95	CHEV/GMC Truck K3500
700223#	95-98	ACURA TL
	92-94	ACURA Vigor
700225#	94-97	MERC Truck Villager
	94-97	NISSAN Truck Quest
700226	94-97	DODGE/PLYM Truck R1500, R2500
700227	94-96	DODGE/PLYM Truck Dakota
700228#	1994	CAD Deville
700229#	93-94	CAD Eldorado, Seville, Dual Ex. (Right)
700230#	93-94	CAD Eldorado, Seville, Dual Ex. (Left)
700231#	94-96	BUICK Roadmaster Sedan, Sgl. Exh. (Rear); Dual Exh. (Right Rear)
	94-96	CHEV Caprice, Sedan, Sgl. Exh. (Rear); Dual Exh. (Right Rear)
700232#	94-96	BUICK Roadmaster Sedan, Dual Exh. (Left Rear)
	94-96	CHEV Caprice, Dual Exh. (Left Rear)
700234	02-05	BUICK Rendezvous
	94-99	BUICK LeSabre
	02-07	JEEP Truck Liberty
	94-99	OLDS 88
	01-05	PONT Aztek
	94-99	PONT Bonneville

MSL NUMERICAL LISTING

Muffler includes bracket.

P/N	YEAR	APPLICATION
700235#	94-96	BUICK Regal
	1994	CHEV Lumina
	94-97	OLDS Cutlass Supreme
	94-96	PONT Grand Prix
700236#	86-87	LINC Continental, Dual Exh. (Right)
	86-92	LINC Mark VII, Dual Exh. (Right)
700237#	86-87	LINC Continental, Dual Exh. (Left)
	86-92	LINC Mark VII, Dual Exh. (Left)
700238#	95-00	FORD Contour 4 Cyl. (Rear)
	95-00	MERC Mystique 4 Cyl. (Rear)
700240#	95-00	NISSAN Maxima
	96-99	INFINITI I30
700241#	95-98	NISSAN 200SX
	95-99	NISSAN Sentra
700242#	1998	CHEV Truck Tracker, 2-Dr. Models
	94-97	GEO Truck Tracker, 2-Dr. & Convertibles
	94-98	SUZUKI Truck Sidekick; Convertible
700243#	1998	CHEV Truck Tracker, 4-Dr. Models
	96-97	GEO Truck Tracker, 4-Dr. Hardtop
	93-98	SUZUKI Truck Sidekick; 4-Dr. Hardtop
700244#	96-98	PONT Grand Am GT, Dual Exh. (Right)
	1995	PONT Grand Am, Dual Exh. (Right)
700245	96-98	PONT Grand Am GT, Dual Exh. (Left)
	1995	PONT Grand Am, Dual Exh. (Left)
700246#	95-01	CHEV Lumina
	95-99	CHEV Monte Carlo
700247#	95-03	FORD Truck Windstar
	04-07	FORD/MERC Truck Freestar, Monterey
700248#	94-97	HONDA Truck Passport
	93-97	ISUZU Truck Rodeo
700249#	92-95	ISUZU Truck Trooper
700250#	96-97	CHRY Cirrus
	95-97	DODGE/PLYM Stratus, Breeze
700252	95-12	TOYOTA Truck Tacoma Pickup
	95-98	TOYOTA Truck T100 Pickup
	00-06	TOYOTA Truck Tundra Pickup
700254	96-05	CHEV/GMC Truck Astro/Safari Van
700255#	96-99	FORD/MERC Taurus, Sable, Dual Exh. (Right)
700256#	96-99	FORD/MERC Taurus, Sable, Sgl. Exh., Dual Exh. (Left)
700257	96-07	CHRY Truck Town & Country
	96-07	DODGE/PLYM Truck Caravan, Voyager
	96-05	DODGE/PLYM Truck Grand Caravan, Grand Voyager

P/N	YEAR	APPLICATION
700258	99-00	CAD Escalade
	96-99	CHEV/GMC Truck C1500, C2500
	99-00	CHEV/GMC Truck Denali
	96-99	CHEV/GMC Truck K1500, K2500
	96-00	CHEV/GMC Truck Tahoe/Yukon
700259	97-99	DODGE/PLYM Truck Dakota
700260	96-00	CHEV/GMC Truck C1500, C2500; Suburban
	96-00	CHEV/GMC Truck K1500, K2500; Suburban
	96-00	CHEV/GMC Truck Tahoe/Yukon
700261#	95-99	CHEV Lumina, Monte Carlo, Dual Exh. (Right)
700262#	95-99	CHEV Lumina, Monte Carlo, Dual Exh. (Left)
700263	97-00	JEEP Truck Wrangler
700264	76-78	DODGE/PLYM Truck B100, BF100, B200, BF200, B300, BF300, CB300, MB300/MB400, PB100, PB200, PB300
	84-91	JEEP Truck Grand Wagoneer
	80-82	JEEP Truck Series 10, Wagoneer, Cherokee
	1983	JEEP Truck Wagoneer, Cherokee
700265#	85-90	CHEV Corvette, exc. ZR1, Dual Exh. (Left)
700266#	85-90	CHEV Corvette, exc. ZR1, Dual Exh. (Right)
700270#	88-97	FORD Truck F250, F350 Series
700272#	90-93	FORD Mustang
700274#	94-96	FORD Truck E250, E350 Series; Econoline, exc. Cutaway Van
	88-93	FORD Truck E250, E350 Series; Econoline, exc. Cutaway Van; exc. 1993 7.5L w/ Round Muffler
700276	95-97	CHEV Camaro
	91-92	CHEV Camaro
	96-97	PONT Firebird
	91-92	PONT Firebird
700277	1991	DODGE/PLYM Truck Dakota
700280#	91-97	HONDA Accord LX; Sta. Wag.
700281	90-94	VW Passat Sedan, Sta. Wag. (Rear)
700282	91-93	BUICK Park Avenue, exc. 92-93 Supercharged Eng.
	92-93	OLDS 98, exc. Supercharged Eng.
700284#	90-94	SUBARU Legacy 4-Dr. Sedan; exc. Turbo (Through 02/94)
700286#	92-95	CHEV/GMC Truck Lumina APV
	92-95	OLDS/PONT Truck Silhouette, Trans Sport
700289#	92-96	HONDA Prelude, All Models

Muffler includes bracket.

MUFFLER NUMERICAL LISTING

MAXIMUM® **TMSL**®

P/N	YEAR	APPLICATION
700290	89-91	CAD DeVille, Fleetwood
700291#	97-00 98-00	FORD Truck Explorer 4-door MERCURY Truck Mountaineer
700292	00-04 00-01	CHEV/GMC Truck Blazer, Jimmy, Envoy (S Series) OLDSMOBILE Truck Bravada
700293	05-08 97-04 05-07 00-05 00-05 97-08	Buick Lacrosse (Front) BUICK Regal (Front) BUICK Allure (Front) CHEV Impala (Front) CHEV Monte Carlo (Front) PONT Grand Prix (Front)
700294#	95-02	KIA Truck Sportage
700295	98-02	DODGE/PLYM Truck Series R1500
700296#	97-03 04-05 97-99	CHEV Malibu CHEV Classic OLDSMOBILE Cutlass
700297	97-04 97-99	FORD Truck F150 Series FORD Truck F250 Series
700298#	05-08 05-07 00-05 97-08	BUICK Lacrosse, Dual Exh. (Right) BUICK Allure, Dual Exh. (Right) CHEV Monte Carlo, Dual Exh. (Right) PONT Grand Prix, Dual Exh. (Right)
700299#	97-00	FORD Truck Explorer 2-door
700300#	05-08 05-07 00-05 97-08	BUICK Lacrosse, Dual Exh. (Left) BUICK Allure, Dual Exh. (Left) CHEV Monte Carlo, Dual Exh. (Left) PONT Grand Prix, Dual Exh. (Left)
700301	98-03	DODGE/PLYM Truck Series B150 Vans, Wagons
700303	02-05 99-06 99-00	CAD Truck Escalade CHEV/GMC Truck C1500/K1500 Silverado/Sierra, Avalanche, Suburban, Tahoe, Yukon CHEV/GMC Truck C2500/K2500 Silverado/Sierra
700304	97-03	FORD Truck E Series, Econoline
700305	96-99	CHEV/GMC Truck C1500/K1500, C2500/K2500 Pickup
700306#	98-02 98-04	CHRY Concorde (Rear) DODGE Intrepid (Rear)
700307#	96-98 97-98	FORD Truck Explorer 5.0L, 4-door MERCURY Truck Mountaineer
700308#	98-02 98-02	CHEV Prizm TOYOTA Corolla
700309	88-92 91-95	VOLVO 700 Series (Rear) VOLVO 900 Series (Rear)
700310#	94-98	FORD Mustang 6 Cyl.
700311#	98-03	DODGE/PLYM Truck Durango
700312	95-98	FORD Truck Windstar (Rear)

P/N	YEAR	APPLICATION
700314#	98-02	FORD/LINC/MERC Full-Size Models, Sgl. Exh., Dual Exh. (Right)
700315#	98-02	FORD/LINC/MERC Full-Size Models, Dual Exh. (Left)
700317#	94-96	CAD Fleetwood Brougham 5.7L, Dual Exh. (Both Rear)
700319	00-05	BUICK/PONT LeSabre, Bonneville; Park Avenue (04-05); (Front)
700320	90-97	MAZDA MX-5 Miata
700322#	88-93	DODGE Truck D250/350, W250/350, Turbo Diesel Eng.
700323#	1996	GM Truck Lumina APV, Silhouette, Trans Sport
700324#	96-97	TOYOTA Truck RAV-4
700325#	98-00	TOYOTA Truck RAV-4
700327	98-04	CHRY/DODGE 300M, Concorde, Intrepid, LHS, 3.2L & 3.5L (Front)
700328	98-04	CHRY/DODGE Concorde, Intrepid 2.7L (Front)
700329	00-06	JEEP Truck Wrangler
700330#	94-04	FORD Mustang GT, Mach 1 (03-04) Dual Exh. Left; 6 Cyl. (99-04)
700331#	94-04	FORD Mustang GT, Mach 1 (03-04) Dual Exh. Right
700333#	97-08	BUICK/CHEV/PONT Century 3.1L; Monte Carlo 3.4L (00-05); Grand Prix (97-08)
700334#	95-96	BUICK Regal 3.8L
700335	02-05	FORD/MERC Truck Explorer, Mountaineer
700336#	93-95	CHEV/GMC Truck C/K1500, C/K2500, C/K3500 Turbo Diesel
700337	96-07	CHRY/DODGE/PLYM Truck Caravan/Voyager, Grand Caravan, Grand Voyager 4 Cyl.
700338#	97-04	BUICK Regal
700339	97-01	GM Truck Venture, Silhouette (97-01); Montana (99-01); Trans Sport (97-98); Extended Wheelbase
700340#	95-99	HONDA/ISUZU Truck Odyssey (95-98); Oasis (96-99); (Front)
700341	97-01	GM Truck Venture, Silhouette (97-99); Montana (99-01); Trans Sport (97-98); Standard Wheelbase
700342#	00-05	CHEV Impala
700343	01-05	CHRY/DODGE Truck Town & Country, Grand Caravan 3.8L
700344	97-98 1998	FORD Truck Expedition LINCOLN Truck Navigator
700345	02-09 03-08	GM Truck Rainier (04-07); Trailblazer/Envoy (02-09); Bravada (02-04); (Rear) ISUZU Truck Ascender
700346	99-02	FORD/LINC Truck Expedition, Navigator
700347	90-95	CHEV/GMC Truck C/K3500, 7.4L, Chassis Cab

MSL NUMERICAL LISTING

Muffler includes bracket.

P/N	YEAR	APPLICATION
700348#	98-02	MERC Truck Villager (Rear)
	98-02	NISSAN Truck Quest (Rear)
700350	00-05	CHEV/GMC Truck Blazer/Jimmy S/T, 2-door
700351#	94-01	ACURA Integra RS, LS, GS 3-door
700352#	94-01	ACURA Integra RS, LS, GS 4-door
700353#	96-97	TOYOTA Paseo
	95-98	TOYOTA Tercel
700356#	1996	FORD Truck F150 5.0L, including Supercab
700357	95-05	BUICK/OLDS Aurora/Riviera (95-99); Park Avenue (97-05); Dual Exh. (Both)
700359	83-90	CHEV/PONT Camaro/Firebird Z-28, IROC-Z, Trans Am
700360	90-93	BUICK/CAD/OLDS Riviera (91-93); Eldorado/Seville (90-92); Toronado (91-92)
700362	99-01	JEEP Truck Grand Cherokee 6 Cyl.
700364	99-01	JEEP Truck Grand Cherokee 8 Cyl.
700365	96-00	CHEV/GMC Truck C/K2500, C/K3500, 155" WB, Old Body Style
700366	01-06	FORD/MERC Truck Explorer, Mountaineer (06-08); Sport Trac (01-05)
700367#	99-04	FORD Truck F250, F350, Super Duty
700368#	98-02	HONDA Accord Coupe & Sedan V6 Dual Exh. (Right)
700369#	00-05	DODGE/PLYM Neon
700370#	00-03	DODGE Truck Durango 8 Cyl.
700371	97-01	BUICK Park Avenue (Rear)
700373	00-05	BUICK/PONT LeSabre, Bonneville (Rear)
700374	00-05	CAD Deville, Dual Exh. (Both Sides)
	98-03	CAD Seville, Dual Exh. (Both Sides)
	06-11	CAD DTS, Dual Exh. (Both Sides)
	95-02	LINCOLN Continental, Dual Exh. (Both Sides)
700375	92-93	CAD Deville; Fleetwood (1992)
700376	96-09	GM/SATURN Truck Equinox (05-09); Torrent (06-09); Vue (02-07); S10/S15 V6 (96-04)
	97-00	ISUZU Truck Hombre 2WD
700377#	96-00	CHRY Sebring Convertible
700378	98-04	CHRY/DODGE 300M, Concorde, Intrepid, LHS, 3.2L & 3.5L (Center)
700379	98-04	CHRY/DODGE Concorde, Intrepid 2.7L (Center)
700380	96-99	PONT Bonneville SSE
700381	96-97	CHEV/GMC Truck S10/S15 V6 4WD; 2WD Auto. Trans. (1996)
700382#	98-06	CHRY/DODGE/PLYM Cirrus, Breeze (98-00); Sebring sedan (01-06); Stratus sedan (98-06)
700384#	98-04	CHRY/DODGE Concorde, Intrepid 2.7L (Rear)
700385#	99-04	CHRY 300M, Concorde, LHS 3.5L (Rear)

P/N	YEAR	APPLICATION
700386#	99-04	NISSAN Truck Frontier
	00-02	NISSAN Truck Xterra
700387#	97-01	HONDA Truck CR-V
700388#	00-07	FORD/Merc Taurus, Sable
700389#	03-12	TOYOTA Corolla 4-door sedan
700391#	97-03	TOYOTA Camry 4 Cyl. (97-01); Solara 4 Cyl. (02-03)
	98-02	HONDA Accord DX, LX, EX, SE
700392#	98-02	HONDA Accord DX, LX, EX, SE
700393#	97-98	LEXUS ES300
	97-01	TOYOTA Camry sedan V6
700394#	96-02	TOYOTA Truck 4-Runner 6 Cyl., exc. Calif.
700395#	96-00	TOYOTA Truck 4-Runner 4 Cyl.
700396#	01-10	CHRY PT Cruiser, exc. Turbo
700397#	93-00	VOLVO 850, exc. Turbo (93-97); C70/S70/V70 exc. Turbo (98-00)
	95-97	CHRY/DODGE Cirrus, Stratus 6 Cyl.
700398#	95-97	CHRY/DODGE Cirrus, Stratus 6 Cyl.
700399#	98-03	TOYOTA Truck Sienna Van, exc. Calif.
700400#	94-95	HONDA Accord EX Sta. Wgn.
700401#	99-03	CHEV/SUZUKI Truck Tracker/Vitara 2-door
700403#	98-00	NISSAN Truck Frontier 4 Cyl.
700406#	98-01	NISSAN Altima
700407#	00-03	DODGE Truck Dakota 112" WB, 131" WB Club Cab
700408#	3/94-99	SUBARU Legacy 4-door sedan, 2.2L
	98-04	KIA Sephia (98-01); Spectra (00-04)
700409#	98-04	KIA Sephia (98-01); Spectra (00-04)
700411#	98-02	HONDA Accord Coupe & Sedan V6 Dual Exh. (Left)
	94-99	SUBARU Legacy 2.2L Sta. Wgn.
700413#	96-99	SUBARU Legacy Outback
700414	02-04	JEEP Truck Grand Cherokee 6 Cyl.
700415#	99-03	MAZDA Protégé, exc. Mazdaspeed
700416#	98-2/02	SUBARU Forester
700417#	4/99-03	NISSAN Maxima, exc. Calif.
700418#	98-02	MAZDA 626, 2.0L
700419#	97-99	ACURA CL 6 Cyl.
700420#	04-12	CHEV/GMC Truck Colorado, Canyon
	06-08	ISUZU Truck I280/I350 Pickup
700422#	04-11	FORD Truck Ranger, exc. Calif.
	04-09	MAZDA Pickup
700423#	02-06	NISSAN Altima 4 Cyl.
700424#	00-06	NISSAN Sentra 1.8L
700425#	00-01	INFINITI I30, exc. Calif.
700426#	98-04	HONDA/ISUZU Truck Passport (98-02); Rodeo exc. Sport (98-04)
	04-07	CHEV Malibu sedan & Maxx
700427	2008	CHEV Malibu Classic
700428	01-04	FORD/MAZDA Truck Escape, Tribute
700429	02-09	GM Truck Rainier (04-07); Trailblazer/Envoy (02-09); Bravada (02-04); (Front)
	03-08	ISUZU Truck Ascender

Muffler includes bracket.

MUFFLER NUMERICAL LISTING

MAXIMUM® **TMSL**®

P/N	YEAR	APPLICATION
700430#	4/98-01	FORD/MERC Truck Explorer 4-door, Mountaineer 8 Cyl.
700431#	02-06 02-08	LEXUS ES300 (02-03); ES330 (04-06) TOYOTA Camry (02-06); Solara (04-08)
700432#	95-96	LEXUS/TOYOTA ES300, Camry V6
700434	88-96	FORD Truck E350, 158" & 176" WB
700437#	01-05	HONDA Civic DX, EX, GX, HX, LX Sedan & Coupe
700438#	00-02	GM Truck G10/G1500, G20/G2500 Express, Savana
700439#	96-99 96-00	GM Truck G10/G1500, G20/G2500 Express, Savana GM Truck G30/G3500 Express, Savana
700440#	97-03	FORD Truck E150, E250, E350, 5.4L
700441#	96-00	GM Truck G10/G1500, G20/G2500 Express, Savana
700442#	02-05	DODGE Truck R1500 Ram Pickup
700443#	99-04 99-05	OLDS Alero PONT Grand Am, exc. GT w/ Dual Exh.
700445#	99-03 01-04 99-05	CHEV/SUZUKI Truck Tracker/Vitara 4 Cyl., 4-door CHEV Truck Tracker 6 Cyl., 4-door SUZUKI Truck Grand Vitara 6 Cyl.
700446	97-05 95-99	BUICK Park Avenue (Front) BUICK/OLDS Riviera, Aurora (Front)
700447#	92-94 92-94	LEXUS ES300 TOYOTA Camry V6
700448#	92-93 94-96	TOYOTA Camry 2.2L, exc. Calif. TOYOTA Camry 2.2L
700449	06-11 06-07	CHEV Impala 6 Cyl., 3.5L (Front) CHEV Monte Carlo 6 Cyl., 3.5L (Front)
700450#	06-11 06-07	CHEV Impala 6 Cyl., 3.5L (Rear) CHEV Monte Carlo 6 Cyl., 3.5L (Rear)
700451#	06-11 06-09	CHEV Impala 6 Cyl., 3.9L (Right) CHEV Impala SS 8 Cyl., 5.3L (Right)
700452#	06-11 06-09	CHEV Impala 6 Cyl., 3.9L (Left) CHEV Impala SS 8 Cyl., 5.3L (Left)
700453#	00-01 00-03	FORD Explorer 4-door, SOHC (Code "E") 4.0L (From 12/99) FORD Explorer Sport 2-door, SOHC (Code "E") 4.0L (From 12/99)
700454#	03-04	NISSAN Xterra 6 Cyl., 3.3L
700455#	00-03 00-03	DODGE Dakota Quad Cab 2 & 4 WD, 131" WB, 6 Cyl., 3.9L DODGE Dakota Quad Cab 2 & 4 WD, 131" WB, 8 Cyl., 4.7 & 5.9L
700456#	04-08 04-08	FORD F150 6 Cyl., 126", 133"WB, 4.2L, exc. Heritage Series (Old Body Style) FORD F150 6 Cyl., 139", 145", 150", 163" WB, 4.2L, exc. Heritage Series (Old Body Style)

P/N	YEAR	APPLICATION
700456# (CONT)	04-08 04-08 06-08	FORD F150 8 Cyl., 126", 133"WB, 4.6 & 5.4L, exc. Heritage Series (Old Body Style) FORD F150 8 Cyl., 139", 145", 150", 163" WB, 4.6 & 5.4L, exc. Heritage Series (Old Body Style) LINCOLN Mark LT 139", 150" WB, 8 Cyl., 5.4L
700457#	04-06	NISSAN Titan Pickup King & Crew Cab (XE, SE, LE) 2 & 4 WD, 8 Cyl., 5.6L, exc. Calif.
700458	05-08 05-08 05-06 2008 05-06 2008 05-08 05-08	FORD Escape 4 Cyl., 2.3L FORD Escape 6 Cyl., 3.0L MAZDA Tribute 4 Cyl., 2.3L MAZDA Tribute 4 Cyl., 2.3L MAZDA Tribute 6 Cyl., 3.0L MAZDA Tribute 6 Cyl., 3.0L MERCURY Mariner 4 Cyl., 2.3L MERCURY Mariner 6 Cyl., 3.0L
700459	02-04	JEEP Grand Cherokee 2 & 4 WD, 8 Cyl., 4.7L
700460	2004 2004	DODGE Dakota Dakota Club & Quad Cab 2 & 4 WD, 112", 131" WB, 6 Cyl., 3.7L DODGE Dakota Dakota Club & Quad Cab 2 & 4 WD, 112", 131" WB, 8 Cyl., 4.7L
700461#	00-05	SATURN L Series (Front)
700462#	04-05	DODGE R1500 2 & 4 WD, 120", 140", 160" WB, 8 Cyl., 5.7L Hemi
700463#	2003	DODGE R1500 2 & 4 WD, 120", 140", 160" WB, 8 Cyl., 5.7L Hemi
700464#	03-07	SATURN ION 4 Cyl., 2.2L
700465#	05-10 05-06 07-10	CHEV Cobalt 4 Cyl., 2.2L PONTIAC G5 Pursuit 4 Cyl., 2.2L (Canada only) PONTIAC G5 4 Cyl., 2.2L
700466	05-10 05-10 06-10 06-07	JEEP Grand Cherokee 6 Cyl., 3.7L JEEP Grand Cherokee 8 Cyl., 4.7 & 5.7L JEEP Commander 6 Cyl., 3.7L JEEP Commander 8 Cyl., 4.7 & 5.7L
700467#	03-04	NISSAN Frontier Crew-Cab 2 & 4 WD, 131.1" WB. Long Bed, 6 Cyl., 3.3L
700468	02-06 01-06	CADILLAC Escalade 8 Cyl., 6.0L exc. ESV or EXT Models or Models w/ 20" Wheels GMC Tahoe/Yukon Denali 8 Cyl., 6.0L exc. XL Models
700469	05-07 05-08 02-05 02-04 02-08 05-07	BUICK Terraza CHEV Uplander CHEV Venture OLDS Silhouette PONT Montana SATURN Relay

MSL NUMERICAL LISTING

Muffler includes bracket.

P/N	YEAR	APPLICATION
700470	05-07	BUICK Allure 6 Cyl., 3.8L
	05-09	BUICK Lacrosse 6 Cyl., 3.8L
700471	04-06	CHRYSLER Pacifica 6 Cyl., 3.5L
700472#	04-06	CHRYSLER Pacifica 6 Cyl., 3.5L
700473	08-17	BUICK Enclave 6 Cyl., 3.6L
	07-17	CHEVROLET GMC Acadia 6 Cyl., 3.6L
	09-17	CHEVROLET Traverse 6 Cyl., 3.6L
700474#	2007	CHRYSLER Aspen 8 Cyl., 4.7L, 5.7L
	04-09	DODGE Durango 6 Cyl., 3.7L, 8 Cyl., 4.7, 5.7L
700475#	06-08	DODGE R1500 Series Pickup 6 Cyl., 3.7l, 8 Cyl.,4.7L
700476#	05-09	DODGE R2500/2500 HD/3500 Series Pickup 6 Cyl., 5.9L
700477#	06-08	DODGE R1500 Series Pickup 8 Cyl., 5.7L
700478#	03-09	DODGE R2500/2500 HD/3500 Series Pickup 8 Cyl., 5.7L
700479	07-11	DODGE Nitro 6 Cyl., 3.7L
	08-12	JEEP Liberty 6 Cyl., 3.7L
700480	05-10	DODGE Dakota 6 Cyl., 3.7L, 8 Cyl., 4.7L
	06-09	MITSUBISHI Raider Pickup 6 Cyl., 3.7l, 8 Cyl., 4.7L
	2011	RAM Dakota 6 Cyl., 3.7l, 8 Cyl., 4.7L
700481#	05-07	FORD F250 Series Pickup 10 Cyl., 6.8L, 8 Cyl., 5.4L
	05-07	FORD F350 Series Pickup 10 Cyl., 6.8L, 8 Cyl., 5.4L
700482	04-14	FORD E Series Econoline Vans 8 Cyl., 5.4L
	00-05	FORD Excursion 10 Cyl., 6.8l, 8 Cyl., 5.4L
700483#	99-03	FORD F250 Series Pickup 8 Cyl., 7.3L
	99-03	FORD F350 Series Pickup 8 Cyl., 7.3L
700484	08-12	CHEVROLET Malibu, Classic 4 Cyl., 2.4L
	08-10	PONTIAC G6 4 Cyl., 2.4L
700485#	05-07	BUICK Allure 6 Cyl., 3.8L
	05-09	BUICK Lacrosse 6 Cyl., 3.8L
700486	08-12	CHEVROLET Malibu 6 Cyl., 3.6L
	08-10	PONTIAC G6 6 Cyl., 3.5L, 6 Cyl., 3.6L
700487#	06-11	CHEVROLET HHR 4 Cyl., 2.2L
700488#	01-06	CHEVROLET Silverado / GMC Sierra 2500 Series Pickup 8 Cyl., 6.0L, 8 Cyl., 6.0L, 8.1L, 8 Cyl., 8.1, 6.0L
	04-06	CHEVROLET Silverado / GMC Sierra 3500 Series Pickup 8 Cyl., 8.1, 6.0, 8.1, 6.0, 8 Cyl., 8.1, 6.0L
700489	07-13	CHEVROLET Silverado / GMC Sierra 1500 Series 2wd Pickup 6 Cyl., 4.3L, 8 Cyl., 4.8L, 8 Cyl., 5.3L
	07-13	CHEVROLET Silverado / GMC Sierra 1500 Series 4wd Pickup 8 Cyl., 4.8L, 8 Cyl., 5.3L, 6 Cyl., 4.3L

P/N	YEAR	APPLICATION
700490	99-04	HONDA Odyssey 6 Cyl., 3.5L
700491#	07-15	NISSAN Titan 8 Cyl., 5.6L
709003	1989	EAGLE/RENAULT Medallion
709004		Universal MSL/Maximum Muffler
709005		Universal MSL/Maximum Muffler
709006		Universal MSL/Maximum Muffler
709007		Universal MSL/Maximum Muffler
709008		Universal MSL/Maximum Muffler
709009		Universal MSL/Maximum Muffler
709010		Universal MSL/Maximum Muffler
709011		Universal MSL/Maximum Muffler
709012		Universal MSL/Maximum Muffler
709013		Universal MSL/Maximum Muffler
709014		Universal MSL/Maximum Muffler
709015		Universal MSL/Maximum Muffler
709016		Universal MSL/Maximum Muffler
709017		Universal MSL/Maximum Muffler
709018		Universal MSL/Maximum Muffler
709019		Universal MSL/Maximum Muffler
709020		Universal MSL/Maximum Muffler
709021		Universal MSL/Maximum Muffler
709022		Universal MSL/Maximum Muffler
709023		Universal MSL/Maximum Muffler
709024		Universal MSL/Maximum Muffler
709025		Universal MSL/Maximum Muffler
709027		Universal MSL/Maximum Muffler
709028		Universal MSL/Maximum Muffler
709029		Universal MSL/Maximum Muffler
709030		Universal MSL/Maximum Muffler
709031		Universal MSL/Maximum Muffler
709032		Universal MSL/Maximum Muffler
709033		Universal MSL/Maximum Muffler
709034		Universal MSL/Maximum Muffler
709069		Universal MSL/Maximum Muffler
709114		Universal MSL/Maximum Muffler
709992		Universal MSL/Maximum Muffler
709993		Universal MSL/Maximum Muffler
709994		Universal MSL/Maximum Muffler
709998		Universal MSL/Maximum Muffler
709999	88-89	PONT LeMans

Muffler includes bracket.

STAINLESS STEEL PERFORMANCE MUFFLERS *Reversible*



PERFORMANCE FEATURES

- Heavy gauge 100% Stainless Steel
- All welded construction
- Straight through flow design
- Increased flow
- Excellent performance sound
- Reversible
- High temperature acoustical filler material
- Better performance

4" x 9" OVAL REVERSIBLE

OFFSET/CENTER (4" x 9")

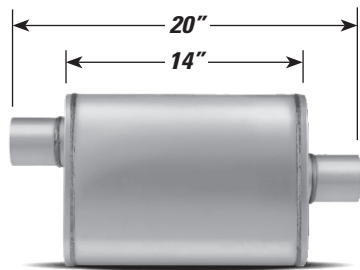

P/N	INLET	OUTLET
XS1224	2"	2"
XS1225	2 ¼"	2 ¼"
XS1226	2 ½"	2 ½"
XS1229	3"	3"

OFFSET/CENTER (4" x 9")

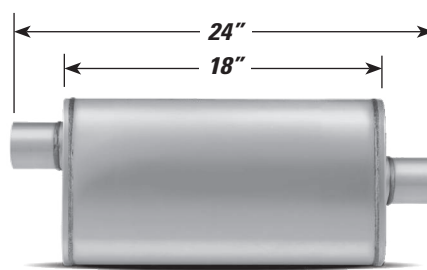

P/N	INLET	OUTLET
XS1255	2 ¼"	2 ¼"
XS1256	2 ½"	2 ½"
XS1259	3"	3"

OFFSET/OFFSET (4" x 9")

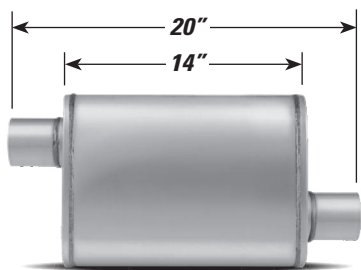

P/N	INLET	OUTLET
XS1235	2 ¼"	2 ¼"
XS1236	2 ½"	2 ½"

OFFSET/OFFSET (4" x 9")

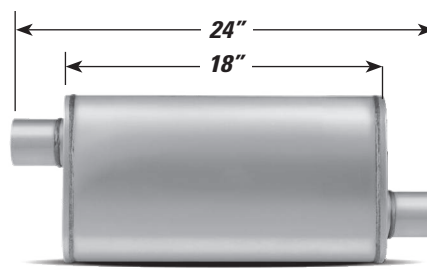

P/N	INLET	OUTLET
XS1266	2 ½"	2 ½"

PERFORMANCE FEATURES

- Heavy gauge 100% Stainless Steel
- All welded construction
- Straight through flow design
- Increased flow
- Excellent performance sound
- Reversible
- High temperature acoustical filler material
- Better performance

4" x 9" OVAL REVERSIBLE

TRANSVERSE & OFFSET/DUALS (4" x 9")

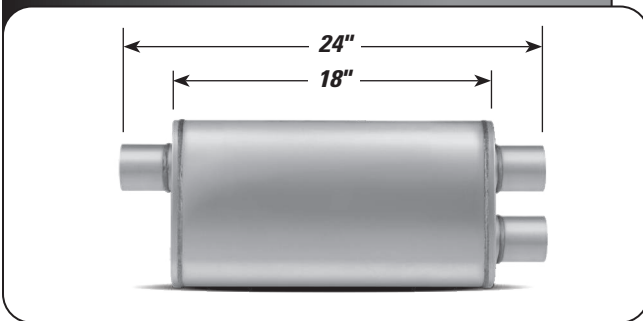

P/N	INLET	OUTLET
XS2265	2 1/2"	2 1/2"

CENTER/DUALS (4" x 9")

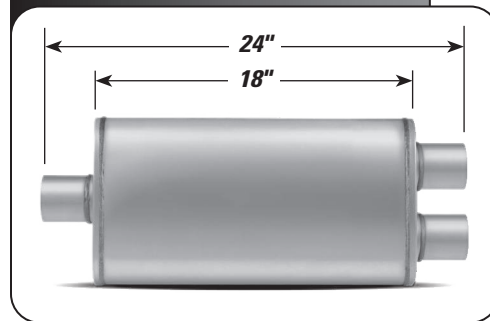

P/N	INLET	OUTLET
XS2258	2 1/2"	2 1/4"
XS2268	2 1/2"	2 1/2"
XS2278	3"	2 1/4"
XS2288	3"	2 1/2"
XS2298	3"	3"

CENTER/DUALS (4" x 9")

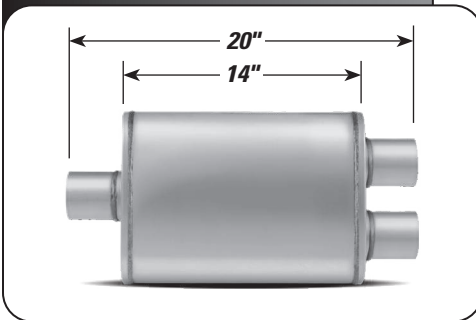

P/N	INLET	OUTLET
XS1149	2 1/4"	2 1/4"
XS2157	2 1/2"	2 1/4"
XS2158	2 1/2"	2 1/2"
XS2197	3"	2 1/4"
XS2198	3"	2 1/2"

STAINLESS STEEL PERFORMANCE MUFFLERS *Reversible*



PERFORMANCE FEATURES

- Heavy gauge 100% Stainless Steel
- All welded construction
- Straight through flow design
- Increased flow
- Excellent performance sound
- Reversible
- High temperature acoustical filler material
- Better performance

5" x 11" LARGE OVAL REVERSIBLE

CENTER/CENTER (5" x 11")

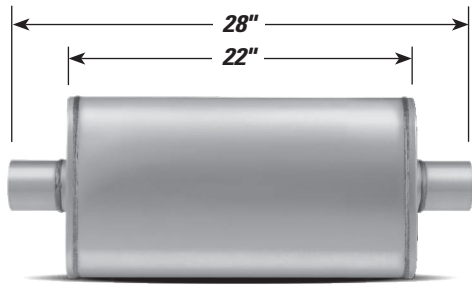

P/N	INLET	OUTLET
XS2579	3"	3"

DUALS/CENTER OR CENTER/DUALS (5" x 11")

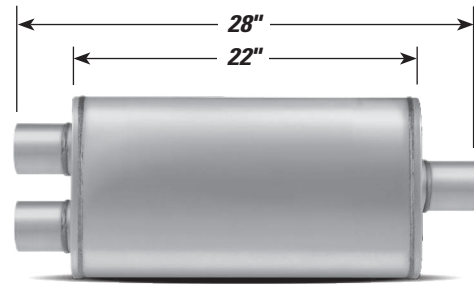

DUALS/CENTER

P/N	INLET	OUTLET
XS2588	2 1/2"	3"

CENTER/DUALS

P/N	INLET	OUTLET
XS2588	3"	2 1/2"

CENTER/OFFSET (5" x 11")

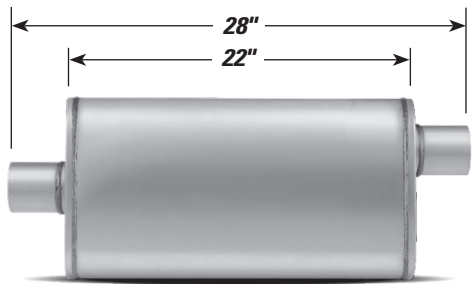

P/N	INLET	OUTLET
XS2589	3"	3"

DUALS/DUALS (5" x 11")

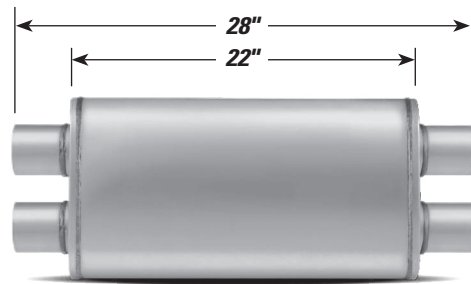

P/N	INLET	OUTLET
XS2568	2 1/2"	2 1/2"

PERFORMANCE

PERFORMANCE FEATURES

- Heavy gauge 100% Stainless Steel
- All welded construction
- Straight through flow design
- Increased flow
- Excellent performance sound
- Reversible
- High temperature acoustical filler material
- Better performance

4" ROUND REVERSIBLE

CENTER/CENTER (4" Round)

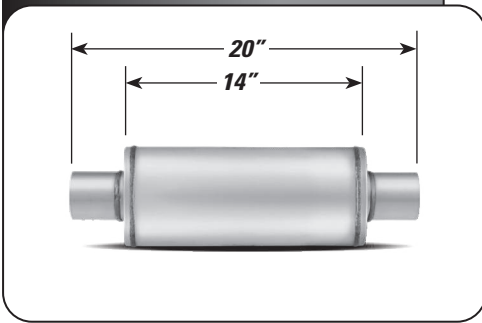

P/N	INLET	OUTLET
XS0445	2 ¼"	2 ¼"
XS0416	2 ½"	2 ½"
XS0433	3"	3"

CENTER/CENTER (4" Round)

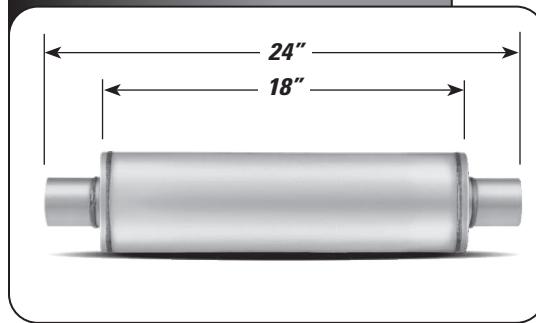

P/N	INLET	OUTLET
XS0425	2 ¼"	2 ¼"
XS0426	2 ½"	2 ½"

7" ROUND REVERSIBLE

CENTER/CENTER (7" Round)

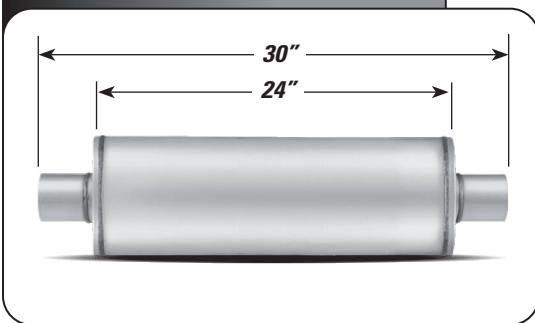

P/N	INLET	OUTLET
XS2772	4"	4"
XS2774	5"	5"

HIGH PERFORMANCE MUFFLERS



VX SERIES HIGH PERFORMANCE MUFFLERS



PERFORMANCE



4 1/4" x 9 1/2" OVAL

CENTER/OFFSET (4 1/4" x 9 1/2")

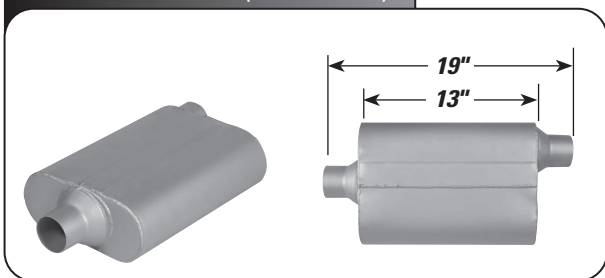

P/N	Inlet	Outlet
VX2442	2 1/4"	2 1/4"
VX2542	2 1/2"	2 1/2"
VX3042	3"	3"

OFFSET/CENTER (4 1/4" x 9 1/2")

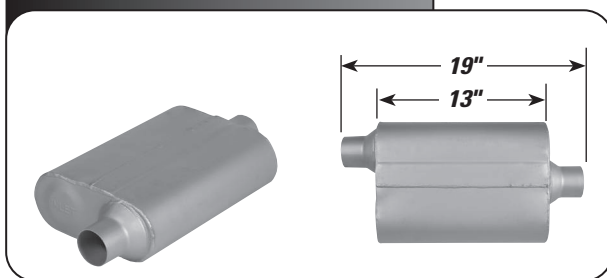

P/N	Inlet	Outlet
VX2441	2 1/4"	2 1/4"
VX2541	2 1/2"	2 1/2"
VX3041	3"	3"

OFFSET/OFFSET (4 1/4" x 9 1/2")

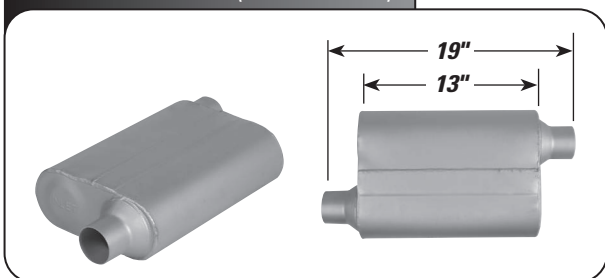

P/N	Inlet	Outlet
VX2443	2 1/4"	2 1/4"
VX2543	2 1/2"	2 1/2"
VX3043	3"	3"

CENTER/DUALS (4 1/4" x 9 1/2")

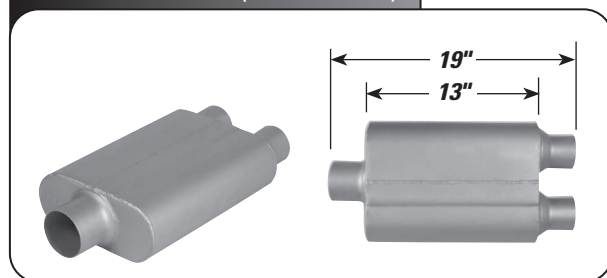

P/N	Inlet	Outlet
VX0402	3"	2 1/2" Duals
VX0422	3"	2 1/4" Duals
VX4422	2 1/4"	2 1/4" Duals
VX5400	2 1/2"	2 1/2" Duals
VX5422	2 1/2"	2 1/4" Duals



VX SERIES

- V-FLOW for deep, aggressive tone
- Better performance
- Increased flow
- 100% Aluminized

DUALS/CENTER (4 1/4" x 9 1/2")

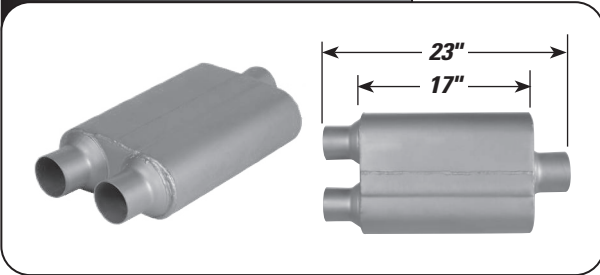

P/N	Inlet	Outlet
VX2552	2 1/2" Duals	2 1/2"

DUALS/DUALS (4 1/4" x 9 1/2")

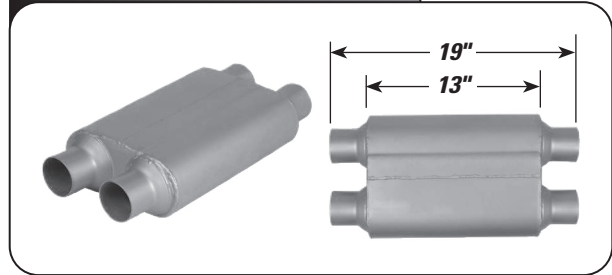

P/N	Inlet	Outlet
VX4134	2 1/4" Duals	2 1/4" Duals

DUALS/DUALS (4 1/4" x 9 1/2")

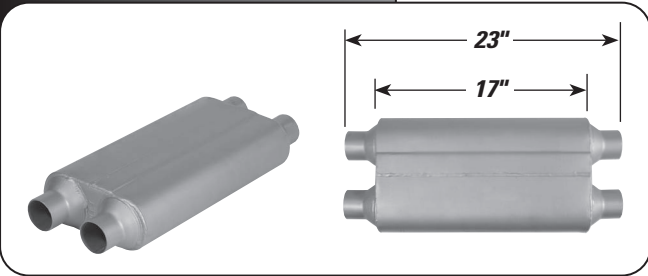

P/N	Inlet	Outlet
VX4554	2 1/4" Duals	2 1/4" Duals

TRANSVERSE (4 1/4" x 9 1/2")

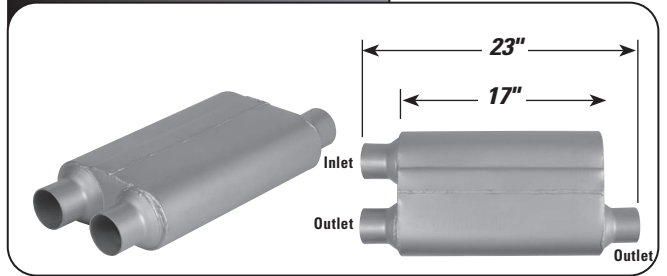

P/N	Inlet	Outlet
VX2583	2 1/2"	2 1/2" Duals Trans

RACE PERFORMANCE MUFFLERS

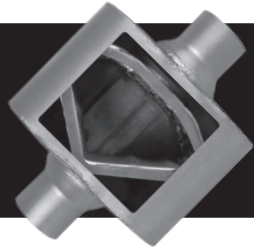

VR SERIES



PERFORMANCE

- V-FLOW for deep, aggressive tone
- Better performance
- Increased flow
- 100% Aluminized

CENTER/CENTER (4 1/4" x 9 1/2")

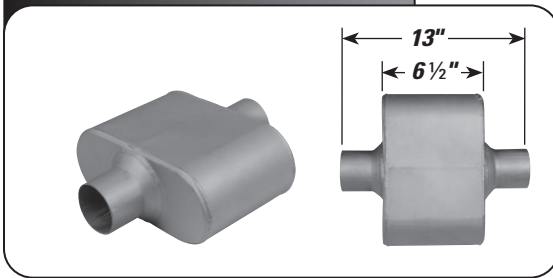

P/N	Inlet	Outlet
VR7426	2 1/2"	2 1/2"
VR7428	3"	3"

CENTER/DUALS (4 1/4" x 9 1/2")

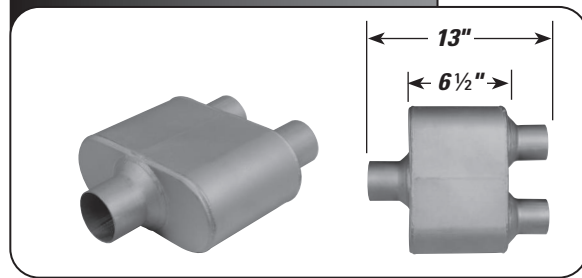

P/N	Inlet	Outlet
VR7425	2 1/2"	2 1/4" Duals
VR7427	3"	2 1/2" Duals

OFFSET/OFFSET (4 1/4" x 9 1/2")

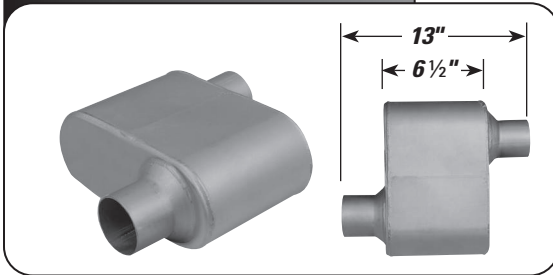

P/N	Inlet	Outlet
VR7429	2 1/4"	2 1/4"
VR7430	2 1/2"	2 1/2"

OFFSET/CENTER (4 1/4" x 9 1/2")

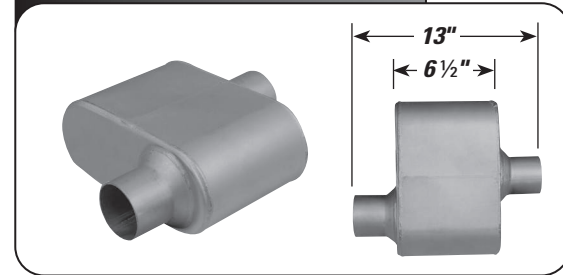

P/N	Inlet	Outlet
VR7431	2 1/4"	2 1/4"
VR7432	2 1/2"	2 1/2"

CHEVROLET/GMC MUFFLERS

1500, 2500, 3500 HeavyDuty 6.0 & 8.1 Litre Gas Engines

PERFORMANCE FEATURES

- All welded construction
- High flow design
- Better performance
- Heavy gauge 100% aluminized steel
- Increased flow
- Excellent performance sound

8 1/2" x 11 3/4"

DUAL OUTLETS FIT OEM TAIL PIPE (8 1/2" x 11 3/4")

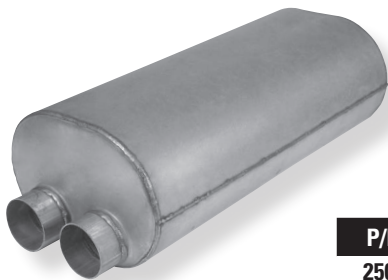

INLET



OUTLET

P/N	SHELL	OAL	INLET	OUTLET
2500	24 1/2"	29"	3" ID Duals	3" OD Duals

- Dual Outlets Fit OEM Tailpipe
- Original Equipment Tuning for OE Sound

SINGLE OUTLET PERFORMANCE OPTION (8 1/2" x 11 3/4")



INLET



OUTLET

P/N	SHELL	OAL	INLET	OUTLET
X503	24 1/2"	29"	3" ID Duals	3" ID

- Use with Xlerator Mandrel Bent Tailpipe X6007 or MaxFit Tailpipe 126584
- Performance Sound on Single Outlet 3" Tailpipe

DUAL OUTLET PERFORMANCE OPTION (8 1/2" x 11 3/4")



INLET



OUTLET

P/N	SHELL	OAL	INLET	OUTLET
X504	24 1/2"	30 1/2"	3" ID Duals	2 1/2" ID Duals

- Full Performance Sound when used with Xlerator Mandrel Bent Tailpipe No.'s X6013 (LS) and X6014 (RS) or Use MaxFit Tailpipes 127670 (LS) and 127671 (RS)

ALL-WELDED PERFORMANCE MUFFLERS



POPULAR OPTIONS FOR DUALING PICKUP TRUCKS

Mandrel Bent Pipes are available.

PERFORMANCE

CHEVY/GMC, DODGE, FORD

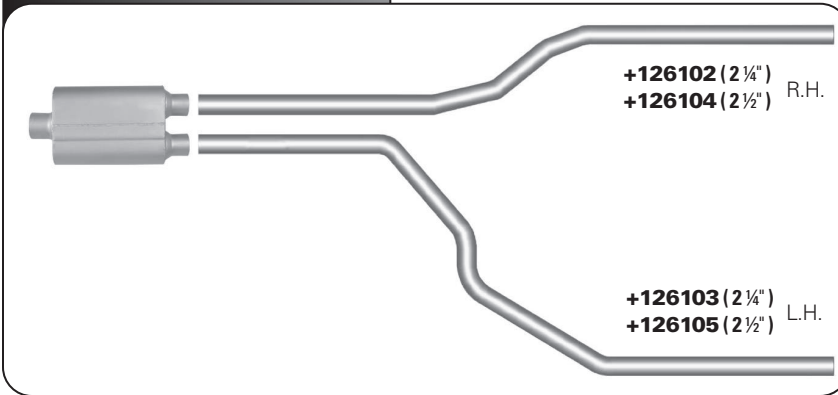

P/N	INLET	OUTLET	BRAND
XS1149	2 1/4"	2 1/4" Duals	XLERATOR
XS2157	2 1/2"	2 1/4" Duals	XLERATOR
XS2158	2 1/2"	2 1/2" Duals	XLERATOR
XS2197	3"	2 1/4" Duals	XLERATOR
XS2198	3"	2 1/2" Duals	XLERATOR
VX4422	2 1/4"	2 1/4" Duals	VX
VX5422	2 1/2"	2 1/4" Duals	VX
VX5400	2 1/2"	2 1/2" Duals	VX
VX0422	3"	2 1/4" Duals	VX
VX0402	3"	2 1/2" Duals	VX
690513	2 1/2"	2 1/4" Duals	TURBO
690514	2 1/2"	2 1/2" Duals	TURBO
690510	3"	2 1/4" Duals	TURBO
690511	3"	2 1/2" Duals	TURBO

CHEVY/GMC, DODGE, FORD

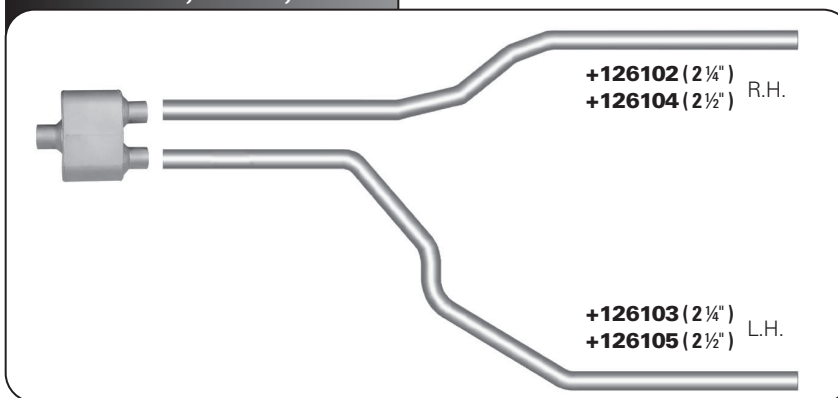

P/N	INLET	OUTLET	BRAND
VR7425	2 1/2"	2 1/4" Duals	VR
VR7427	3"	2 1/2" Duals	VR

+Note: For **MANDREL** Bent Pipes use the following:

For 126102 use **X6102** 2 1/4"

For 126103 use **X6103** 2 1/4"

For 126104 use **X6104** 2 1/2"

For 126105 use **X6105** 2 1/2"

- Ideal For Custom and Dual Installations
- Economically Priced
- Excellent Performance, Sound and Reduced Back-Pressure
- 100% Aluminized Components For Superior Corrosion Protection
- Large Inner Tubes Allow Straight Through Power
- Feature AKDDQ Necks For Easy Modification
- Most Units are Reversible to Limit SKU's
- Large Body 4 1/16" x 10 1/2" and 4 1/2" x 11" Ovals For Light Trucks, Sport Utility Vehicles, Cars and Vans
- Slimmer 4 1/4" x 8 3/4" Ovals to Fit Today's Performance Vehicles
- Smaller 3 1/4" x 7 3/4" Ovals are Also Available to Meet Your Installation Flexibility Needs.

3 1/4" x 7 3/4"

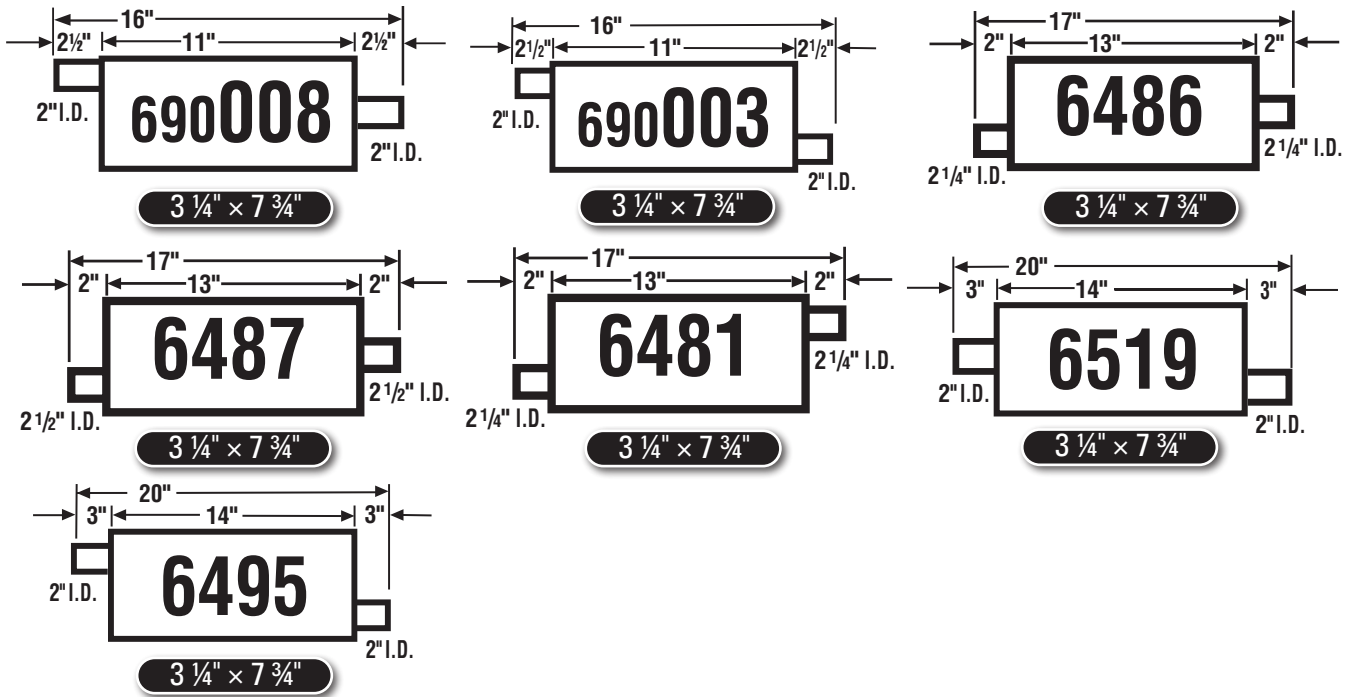

4 1/4" x 8 3/4"

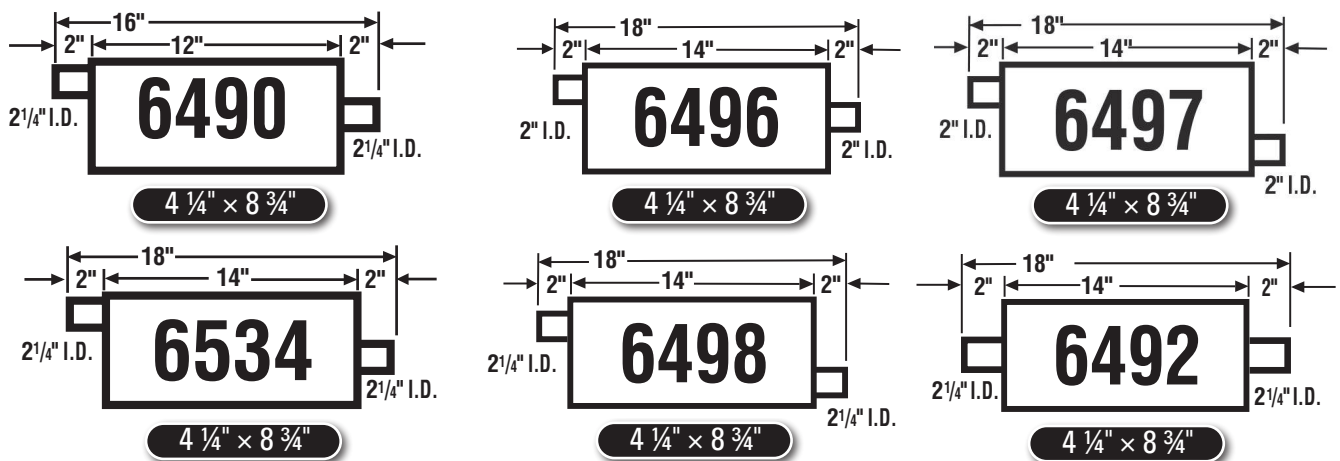

ALUMINIZED TURBO MUFFLERS



PERFORMANCE

4 1/4" x 8 3/4"

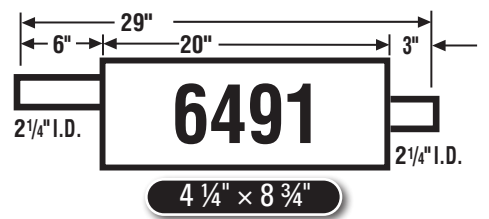
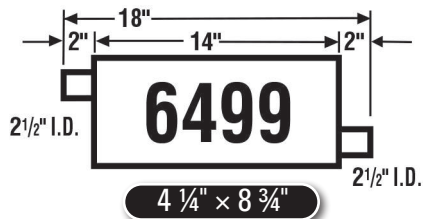
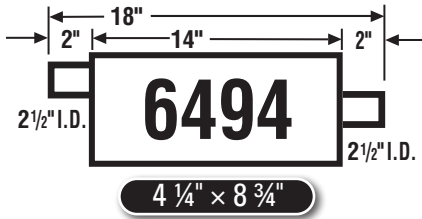

4 1/16" x 10 1/2"

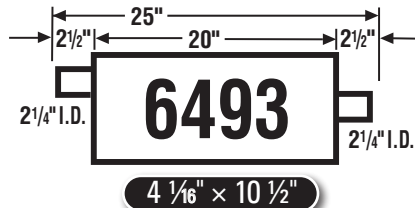
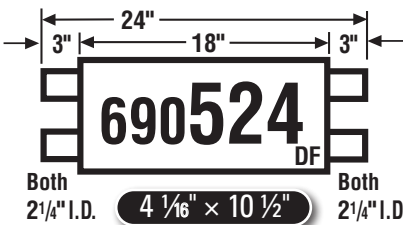
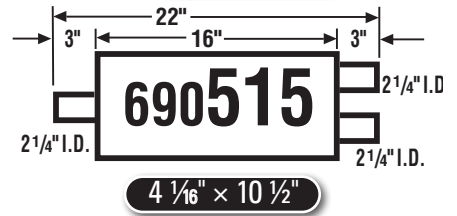
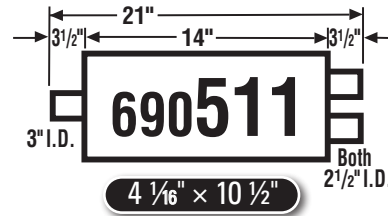
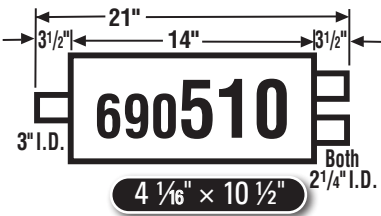
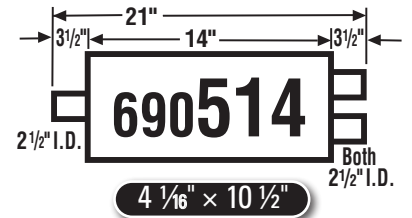
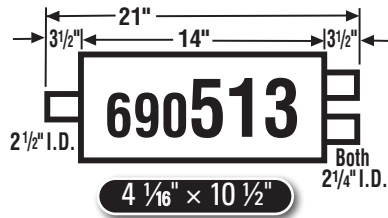
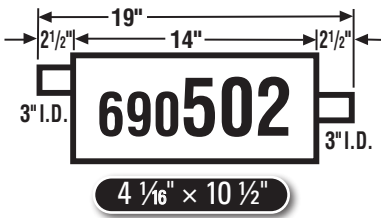
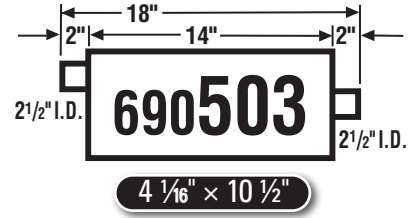
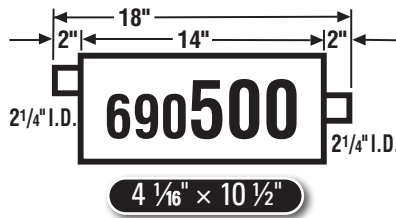
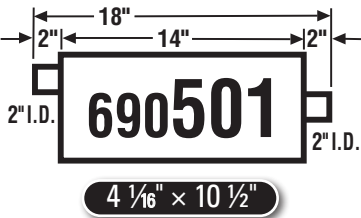

5 1/2" x 11"

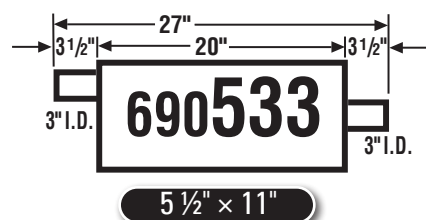
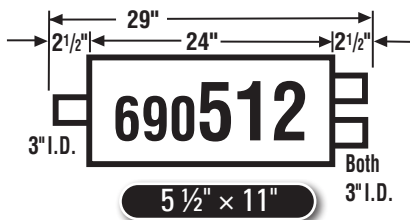

GLASSPACKS

- Aluminized Heavy Duty, 15 Gauge, 3", 3½" and 4" Diameter Shells
- Spiral Louvered Inner Core Produces a Deep, Mellow Tone, Decreases Backpressure and Increases Performance
- AKDDQ Necks Allow For Easy Expansion
- Single Packs

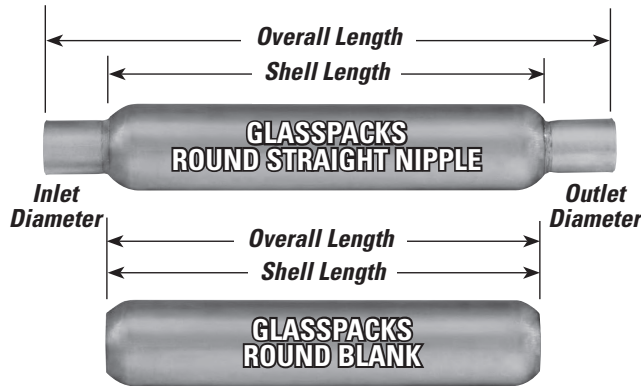

PART NUMBER DEFINITION

Example: 351811

First two digits = Shell Diameter (35=3.5=3½)

Second two digits = Shell Length (18")

Third Two Digits = Configuration:

00 = Blank

11 = Center/Center

12 = Mild Offset/Mild Offset

22 = Full Offset/Full Offset

Seventh digit indicates neck size greater than 2¼":

3 = Two 2½" Necks

4 = Two 3" Necks

Seventh or Eighth digit:

2 = 2¼" Core Size

5 = 2½" Core Size

6 = 3" Core Size

P/N	CASE DIAMETER	CASE LENGTH	CORE DIAMETER	OAL	NECK INLET	NECK OUTLET	NECK CONFIG
3" Case / 1 ¾" Core							
301200S	3"	12"	1 ¾"	12"			Blank
301211S	3"	12"	1 ¾"	18"	1 ¾"	1 ¾"	Straight
301800S	3"	18"	1 ¾"	18"			Blank
301811S	3"	18"	1 ¾"	24"	1 ¾"	1 ¾"	Straight
3 ½" Case / 2" Core							
351200S	3 ½"	12"	2"	12"			Blank
351211S	3 ½"	12"	2"	18"	2"	2"	Straight
351600S	3 ½"	16"	2"	16"			Blank
351611S	3 ½"	16"	2"	22"	2"	2"	Straight
351800S	3 ½"	18"	2"	18"			Blank
351811S	3 ½"	18"	2"	24"	2"	2"	Straight
351812S	3 ½"	18"	2"	24"	2"	2"	Medium
351822S	3 ½"	18"	2"	24"	2"	2"	Full
352200S	3 ½"	22"	2"	22"			Blank
352211S	3 ½"	22"	2"	28"	2"	2"	Straight
352400S	3 ½"	24"	2"	24"			Blank
352411S	3 ½"	24"	2"	30"	2"	2"	Straight
352600S	3 ½"	26"	2"	26"			Blank
352611S	3 ½"	26"	2"	32"	2"	2"	Straight
353000S	3 ½"	30"	2"	30"			Blank
353011S	3 ½"	30"	2"	36"	2"	2"	Straight

ALUMINIZED GLASSPACKS

ENFORCER®

GLASSPACKS - (Cont.)

P/N	CASE DIAMETER	CASE LENGTH	CORE DIAMETER	OAL	NECK INLET	NECK OUTLET	NECK CONFIG
3 ½" Case / 2 ¼" Core							
3512002S	3 ½"	12"	2 ¼"	12"			Blank
3512112S	3 ½"	12"	2 ¼"	18"	2 ¼"	2 ¼"	Straight
3516002S	3 ½"	16"	2 ¼"	16"			Blank
3516112S	3 ½"	16"	2 ¼"	22"	2 ¼"	2 ¼"	Straight
3518002S	3 ½"	18"	2 ¼"	18"			Blank
3518112S	3 ½"	18"	2 ¼"	24"	2 ¼"	2 ¼"	Straight
35181135S	3 ½"	18"	2 ½"	24"	2 ½"	2 ½"	Straight
3518122S	3 ½"	18"	2 ¼"	24"	2 ¼"	2 ¼"	Medium
3522002S	3 ½"	22"	2 ¼"	22"			Blank
3522112S	3 ½"	22"	2 ¼"	28"	2 ¼"	2 ¼"	Straight
35221132S	3 ½"	22"	2 ¼"	28"	2 ½"	2 ½"	Straight
3524002S	3 ½"	24"	2 ¼"	24"			Blank
3524112S	3 ½"	24"	2 ¼"	30"	2 ¼"	2 ¼"	Straight
35241132S	3 ½"	24"	2 ¼"	30"	2 ½"	2 ½"	Straight
3526002S	3 ½"	26"	2 ¼"	26"			Blank
3526112S	3 ½"	26"	2 ¼"	32"	2 ¼"	2 ¼"	Straight
35261132S	3 ½"	26"	2 ¼"	32"	2 ½"	2 ½"	Straight
3530002S	3 ½"	30"	2 ¼"	30"			Blank
3530112S	3 ½"	30"	2 ¼"	36"	2 ¼"	2 ¼"	Straight
35301132S	3 ½"	30"	2 ¼"	36"	2 ½"	2 ½"	Straight
4" Case / 2 ¼" Core							
401800S	4"	18"	2 ¼"	18"			Blank
401811S	4"	18"	2 ¼"	24"	2 ¼"	2 ¼"	Straight
402200S	4"	22"	2 ¼"	22"			Blank
402211S	4"	22"	2 ¼"	28"	2 ¼"	2 ¼"	Straight
403000S	4"	30"	2 ¼"	30"			Blank
403011S	4"	30"	2 ¼"	36"	2 ¼"	2 ¼"	Straight
4" Case / 2 ½" Core							
4012005S	4"	12"	2 ½"	12"			Blank
40121135S	4"	12"	2 ½"	18"	2 ½"	2 ½"	Straight
4018005S	4"	18"	2 ½"	18"			Blank
40181135S	4"	18"	2 ½"	24"	2 ½"	2 ½"	Straight
4024005S	4"	24"	2 ½"	24"			Blank
40241135S	4"	24"	2 ½"	30"	2 ½"	2 ½"	Straight
4530005S	4"	30"	2 ½"	30"			Blank
40301135S	4"	30"	2 ½"	36"	2 ½"	2 ½"	Straight
4" Case / 3" Core							
4012006S	4"	12"	3"	12"			Blank
40121146S	4"	12"	3"	18"	3"	3"	Straight
4018006S	4"	18"	3"	18"			Blank
40181146S	4"	18"	3"	24"	3"	3"	Straight
4024006S	4"	24"	3"	24"			Blank
40241146S	4"	24"	3"	30"	3"	3"	Straight

PERFORMANCE

TURBOPACKS & TORPEDO PACKS

- Featuring The Versatility of a Glasspack with The Sound Performance of a Turbo Muffler
- 2 Tube, 2 Baffle Internal Design Provides Turbo Tuning For Superior Sound Control
- Aluminized Heavy Duty, 15 Gauge, 4" Diameter Shell
- Aluminized AKDDQ Necks Allow For Easy Expansion
- Single Packs

PART NUMBER DEFINITION

Example: 4218112

First two digits = 4" Shell; 2 Designates Turbo Pack

Second two digits = Shell Length (18")

Third Two Digits = Configuration:

11 = Center/Center

12 = Mild Offset/Mild Offset

22 = Full Offset/Full Offset

Seventh digit indicates neck size other than 2" on both ends

1 = One 2 ¼"; One 2" Neck

2 = Two 2 ¼" Necks

3 = Two 2 ½" Necks

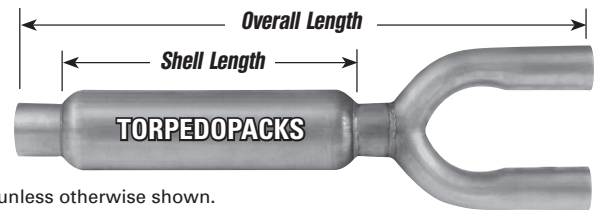
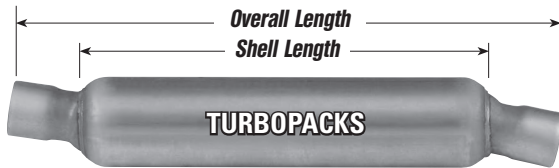

TURBOPACKS * Neck Offset - Inlet and Outlet dimensions I.D. unless otherwise shown.

P/N	CASE DIAMETER	CASE LENGTH	CORE DIAMETER	OAL	NECK INLET	NECK OUTLET	NECK CONFIG
421211S	4"	12"	1 ¾" (2)	18"	2"	2"	Straight
421212S	4"	12"	1 ¾" (2)	18"	2 ¼"	2 ¼"	Straight
421512S	4"	15"	1 ¾" (2)	22"	2"	2"	Medium
421511S	4"	15"	1 ¾" (2)	22"	2"	2"	Straight
4215112S	4"	15"	1 ¾" (2)	22"	2 ¼"	2 ¼"	Straight
4215113S	4"	15"	1 ¾" (2)	22"	2 ½"	2 ½"	Straight
421822S	4"	18"	1 ¾" (2)	25"	2"	2"	Full
421812S	4"	18"	1 ¾" (2)	25"	2"	2"	Medium
4218122S	4"	18"	1 ¾" (2)	25"	2 ¼"	2 ¼"	Medium
421811S	4"	18"	1 ¾" (2)	25"	2"	2"	Straight
4218111S	4"	18"	1 ¾" (2)	25"	2 ¼"	2"	Straight
4218112S	4"	18"	1 ¾" (2)	25"	2 ¼"	2 ¼"	Straight
4218113S	4"	18"	1 ¾" (2)	25"	2 ½"	2 ½"	Straight
422411S	4"	24"	1 ¾" (2)	30"	2"	2"	Straight
4224112S	4"	24"	1 ¾" (2)	30"	2 ¼"	2 ¼"	Straight
4224113S	4"	24"	1 ¾" (2)	30"	2 ½"	2 ½"	Straight

TORPEDOPACKS

P/N	CASE DIAMETER	CASE LENGTH	CORE DIAMETER	OAL	NECK INLET	NECK OUTLET	NECK CONFIG
4115032	4"	15"	2 ½"	29"	Blank - 2 ½"	2 ¼"	Dual Outlet
4115033	4"	15"	2 ½"	29"	Blank - 2 ½"	2 ½"	Dual Outlet
4115042	4"	15"	3"	29"	Blank - 3"	2 ¼"	Dual Outlet
4115043	4"	15"	3"	29"	Blank - 3"	2 ½"	Dual Outlet
4115132	4"	15"	2 ½"	29"	2 ½"	2 ¼"	Dual Outlet
4115133	4"	15"	2 ½"	29"	2 ½"	2 ½"	Dual Outlet
4115142	4"	15"	3"	29"	3"	2 ¼"	Dual Outlet
4115143	4"	15"	3"	29"	3"	2 ½"	Dual Outlet
4118132	4"	18"	2 ½"	31"	2 ½"	2 ¼"	Dual Outlet
4118133	4"	18"	2 ½"	31"	2 ½"	2 ½"	Dual Outlet
4118142	4"	18"	3"	31"	3"	2 ¼"	Dual Outlet

HEADER GASKETS & FLANGES

Allows Exhaust System Installation on Header Equipped Vehicles

GASKETS

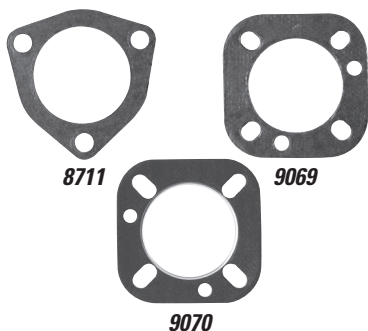

P/N	DESCRIPTION
8711	2 ½" Center Hole Flange Gasket
9069	3" Center Hole Flange Gasket
9070	3 ½" Center Hole Flange Gasket

FLANGES

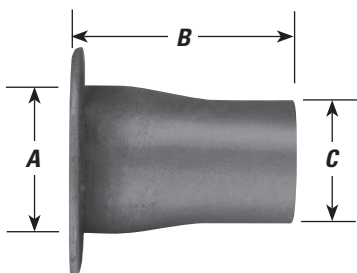

P/N	A	B	C
9071	2 ½"	4"	2 ½" O.D. 3 Hole
9073	3" O.D.	4 ½"	2 ½" O.D. 3 or 4 Hole



- Straight-thru design
- 100% welded construction
- Cherry Bomb Red Paint
- Reversible design for maximum installation flexibility
- Compact round body size
- The original glasspack since 1968



3 1/2" BODY Angled Necks

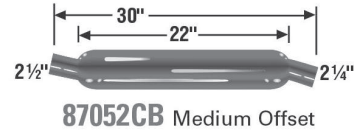
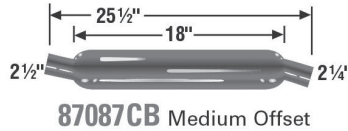
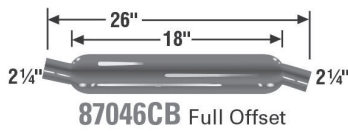
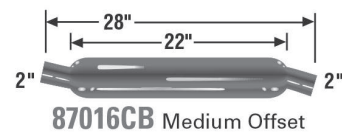
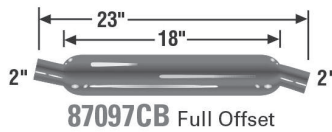
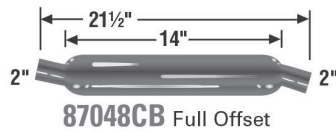

Full Offset - (Used for OFFSET / OFFSET Applications)
 Medium Offset - (Used for OFFSET / CENTER Applications)
 All neck sizes are inside diameter unless otherwise noted.



3½" BODY Straight Necks

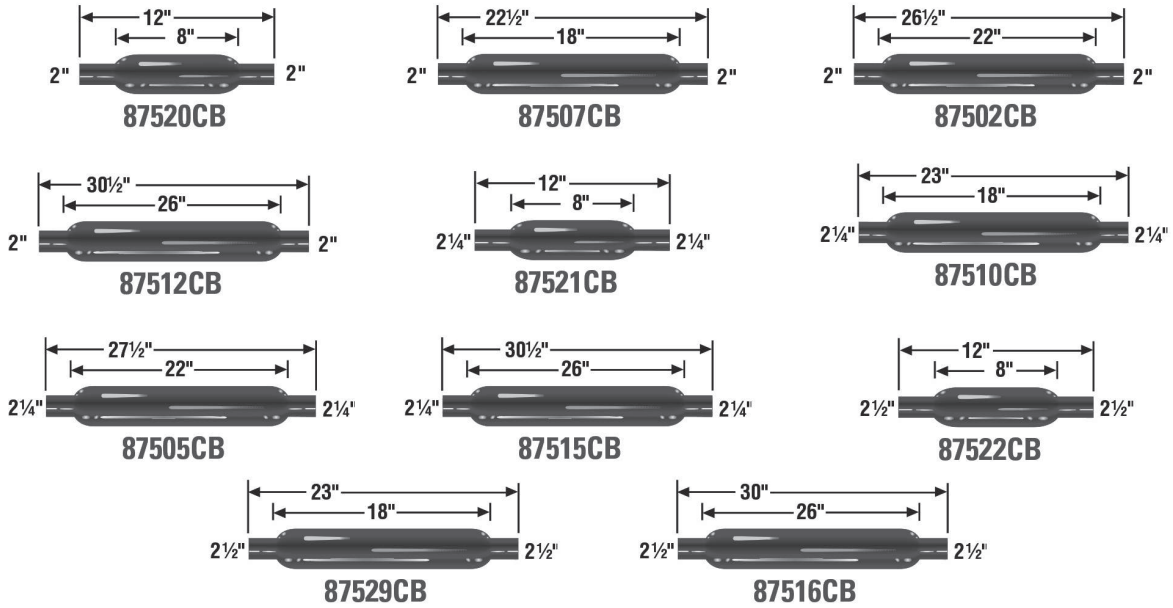

4" BODY Straight Necks

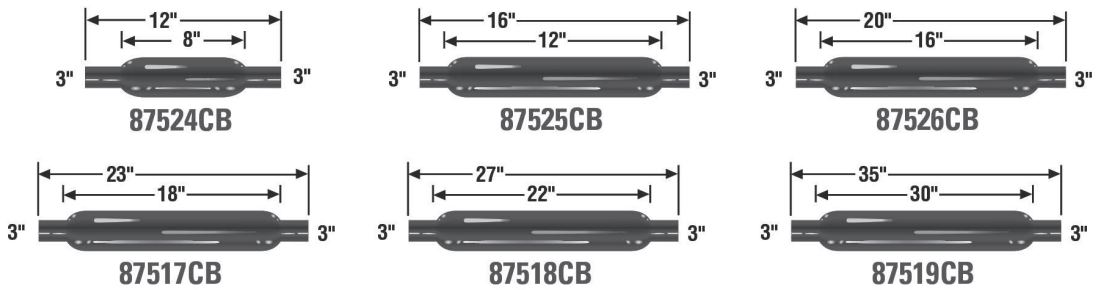

All neck sizes are inside diameter unless otherwise noted.



5" BODY Straight Necks

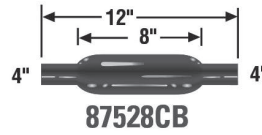
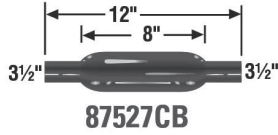

3 1/2" BODY Header Mufflers - Gasket Included

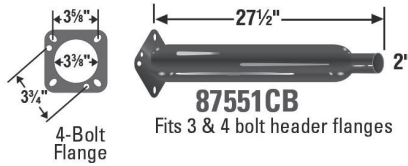
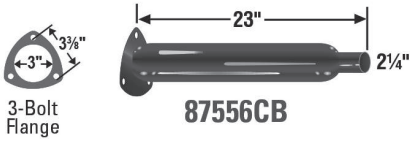

4" BODY Header Muffler - Gasket Included

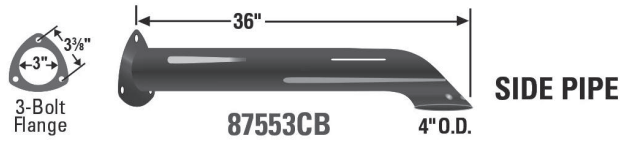

All neck sizes are inside diameter unless otherwise noted.

CHERRY BOMB® M-80 PERFORMANCE MUFFLERS



PERFORMANCE

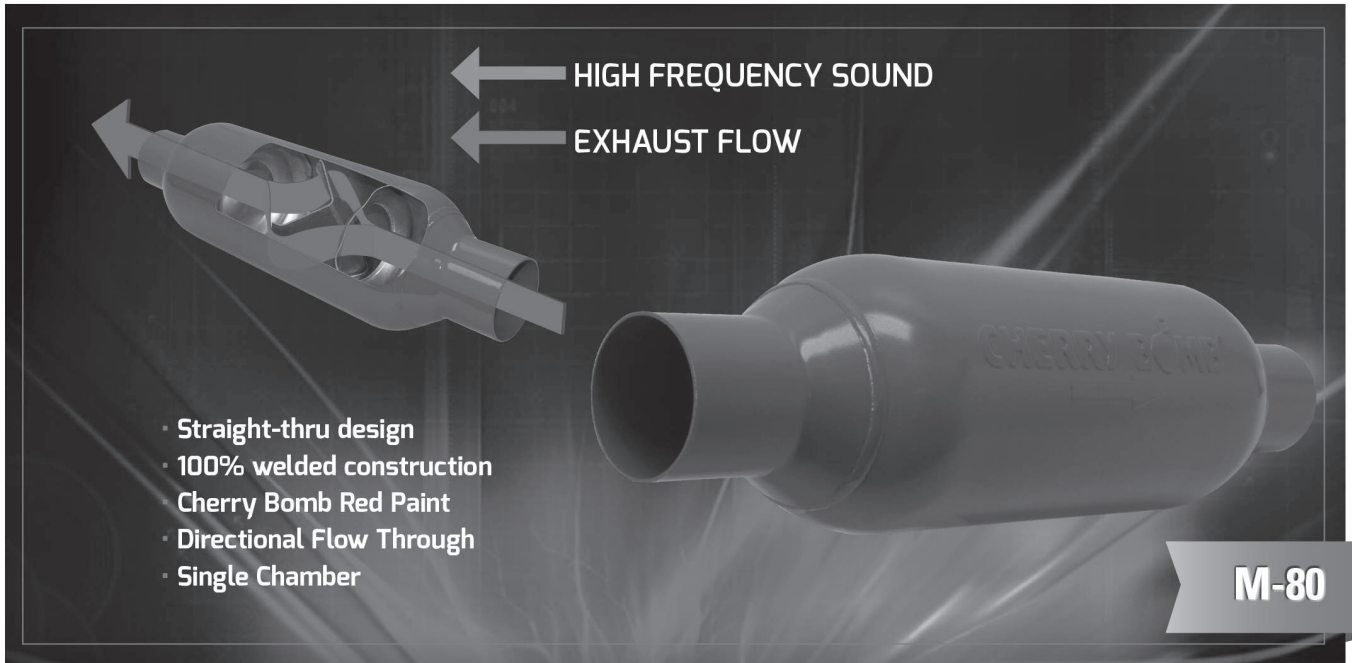

5" BODY Straight Necks



All neck sizes are inside diameter unless otherwise noted.

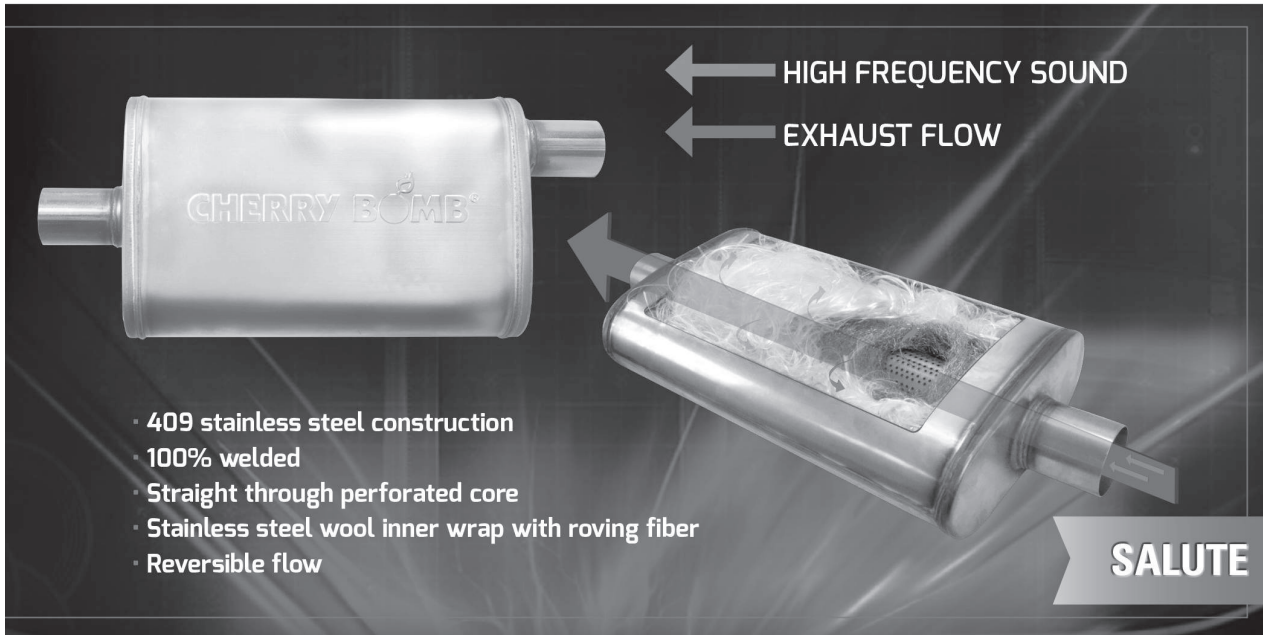

4" x 9" OVAL 14" BODY 20" OVERALL

OFFSET/OFFSET

OFFSET/CENTER



All neck sizes are inside diameter unless otherwise noted.

CHERRY BOMB® SALUTE PERFORMANCE MUFFLERS



4" x 9" OVAL 14" BODY 20" OVERALL

CENTER/DUALS



SA1149



SA2157



SA2158

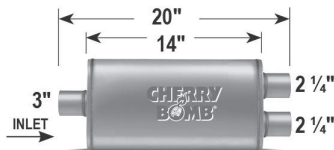

SA2197



SA2198



4" x 9" OVAL 18" BODY 24" OVERALL

OFFSET/OFFSET



SA1266

OFFSET/CENTER



SA1255



SA1256

TRANSVERSE & OFFSET/ DUALS

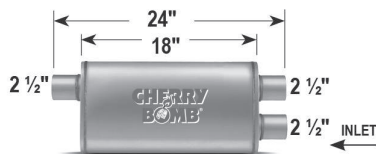

SA2265



SA1259

All neck sizes are inside diameter unless otherwise noted.

PERFORMANCE



4" x 9" OVAL 18" BODY 24" OVERALL

CENTER/DUALS



5" x 11" OVAL 22" BODY 28" OVERALL

DUAL/DUAL



CENTER/DUAL



OFFSET/CENTER



All neck sizes are inside diameter unless otherwise noted.

CHERRY BOMB® SALUTE PERFORMANCE MUFFLERS



PERFORMANCE



4" ROUND 14" BODY 20" OVERALL

CENTER/CENTER



4" ROUND 18" BODY 24" OVERALL

CENTER/CENTER



7" ROUND 24" BODY 30" OVERALL

CENTER/CENTER



All neck sizes are inside diameter unless otherwise noted.

CHERRY BOMB
US PATENT 8906510

HIGH FREQUENCY SOUND
EXHAUST FLOW

- Patented flow divider design with high temp fiberglass
- 100% welded construction
- Grey finish
- Reversible design for maximum installation flexibility
- Standard body size
- Recommended for car, truck and SUV applications

VORTEX



4 1/4" x 10 1/4" OVAL 14" BODY 20 1/2" OVERALL

OFFSET/OFFSET

CENTER/OFFSET

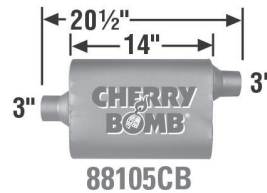
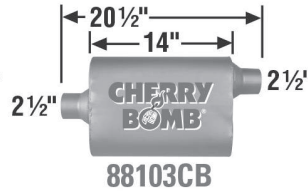
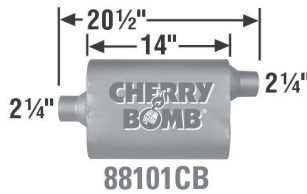

All Vortex Mufflers are Reversible Except for Cross-Flow
All neck sizes are inside diameter unless otherwise noted.

CHERRY BOMB® VORTEX PERFORMANCE MUFFLERS



4 1/4" x 10 1/4" OVAL 16" BODY 22 1/2" OVERALL

CENTER/DUAL

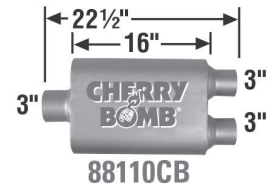
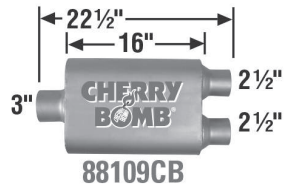
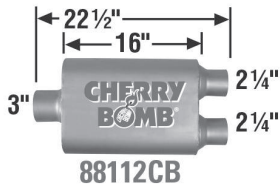
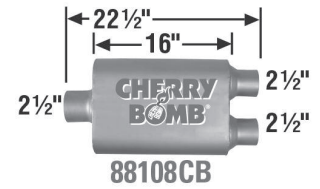
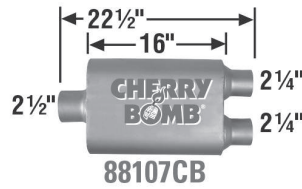
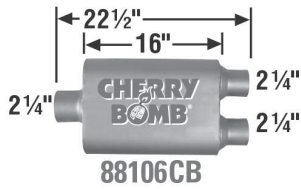

4 1/4" x 10 1/4" OVAL 17" BODY 23 1/2" OVERALL

DUAL/DUAL

Can Be Used As an X-Pipe



CROSS-FLOW

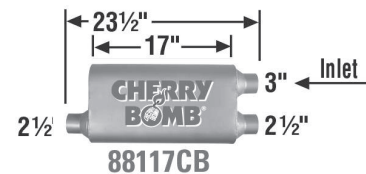
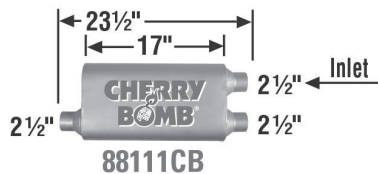

All Vortex Mufflers are Reversible Except for Cross-Flow
All neck sizes are inside diameter unless otherwise noted.

PERFORMANCE

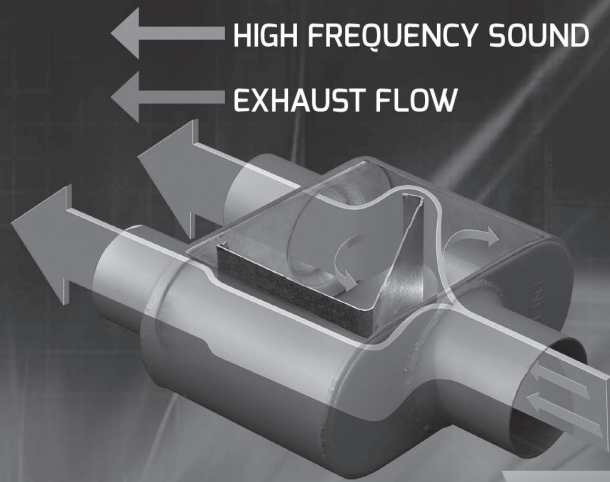
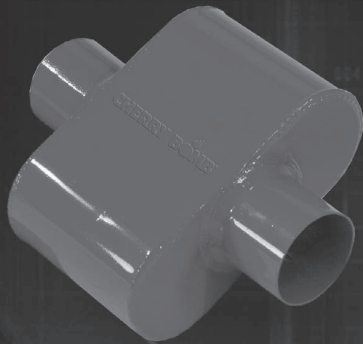

- Short body size with unique wing plate design
- 100% welded construction
- Custom tuned flow design
- Cherry Bomb Red Paint
- Recommended for aggressive sound

EXTREME



4" x 9³/₄" OVAL 6" BODY 12" OVERALL

OFFSET/OFFSET

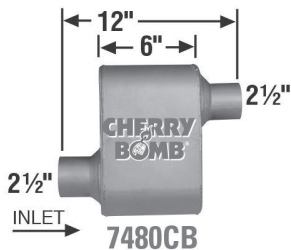

CENTER/CENTER

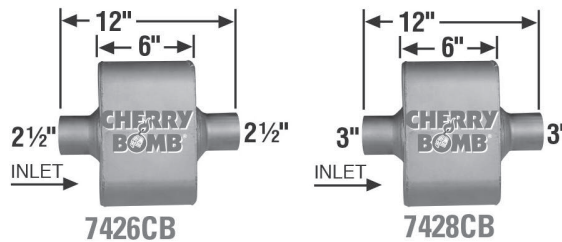

CENTER/DUAL

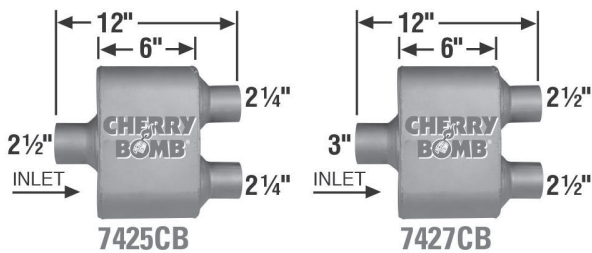

DUAL/DUAL

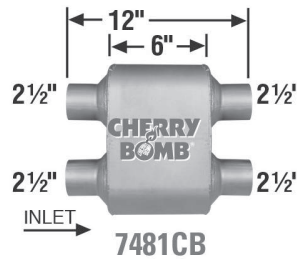

All Pro Mufflers are Directional Flow Design.
All neck sizes are inside diameter unless otherwise noted.

CHERRY BOMB® PRO PERFORMANCE MUFFLERS

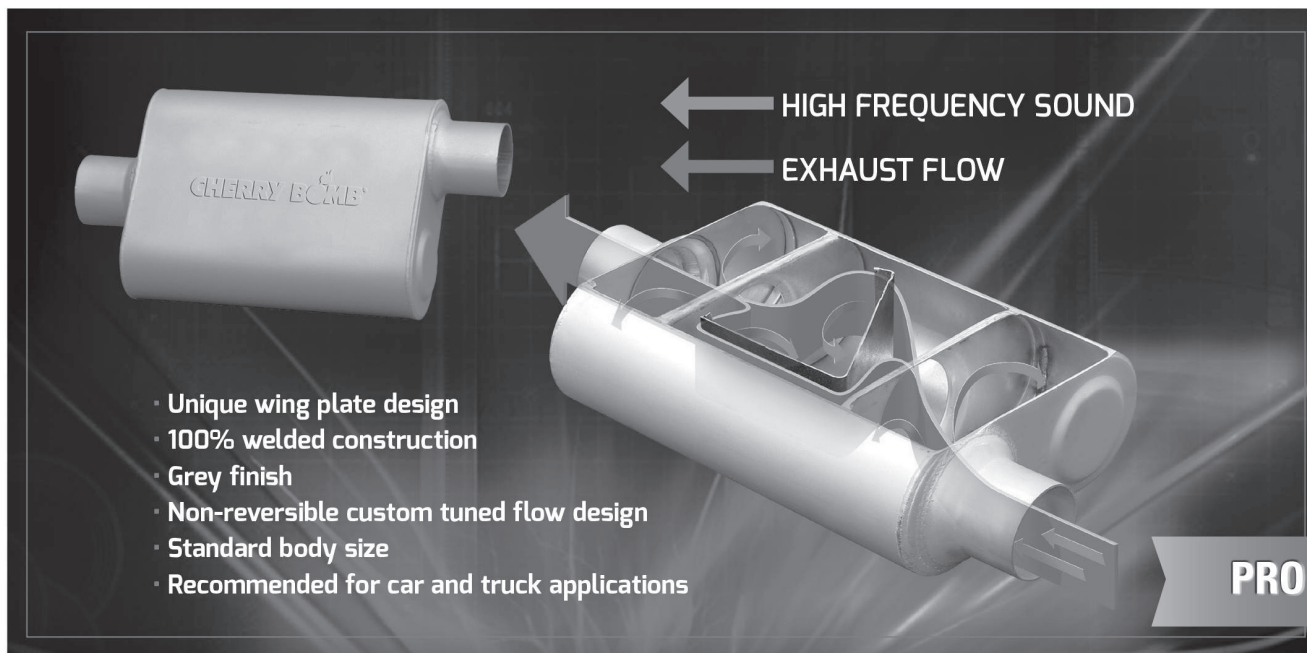

- Unique wing plate design
- 100% welded construction
- Grey finish
- Non-reversible custom tuned flow design
- Standard body size
- Recommended for car and truck applications



4" x 9³/₄" OVAL 13" BODY 19" OVERALL

CENTER/CENTER

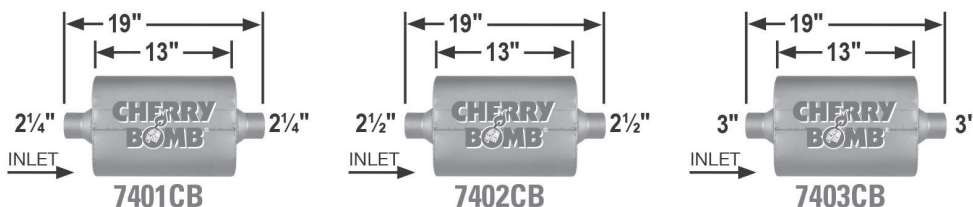

OFFSET/CENTER

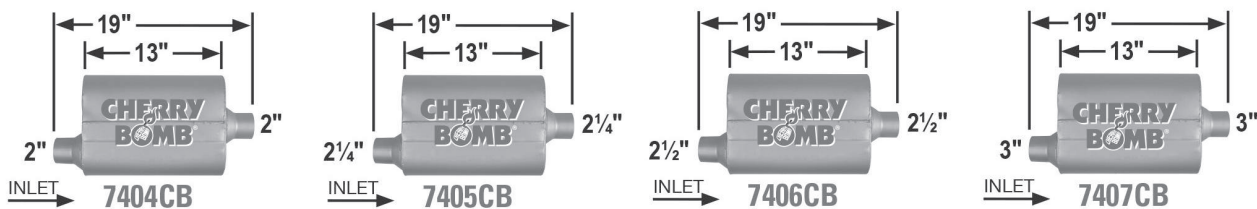

All Pro Mufflers are Directional Flow Design.
All neck sizes are inside diameter unless otherwise noted.



4" x 9³/₄" OVAL 13" BODY 19" OVERALL

CENTER/OFFSET

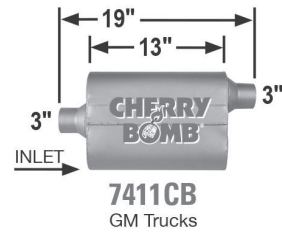
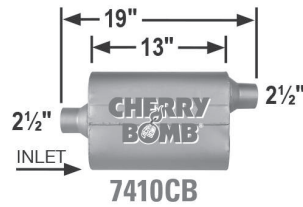
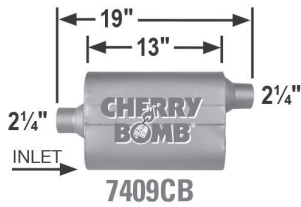

OFFSET/OFFSET

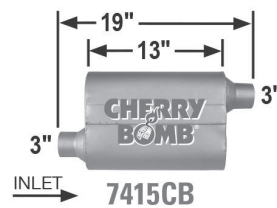
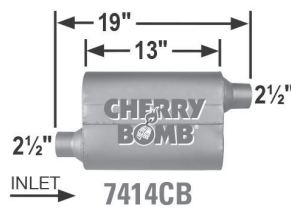
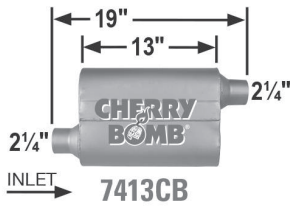

CENTER/DUAL

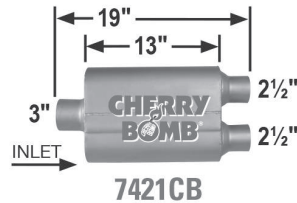
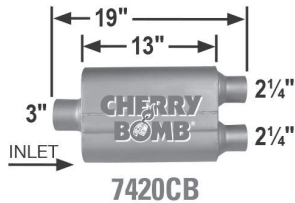
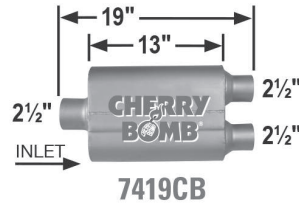
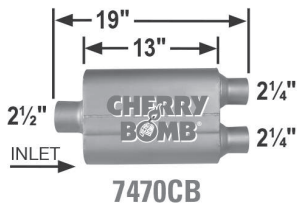

All Pro Mufflers are Directional Flow Design.
All neck sizes are inside diameter unless otherwise noted.



4" x 9³/₄" OVAL 16¹/₂" BODY 22¹/₂" OVERALL

CENTER/OFFSET

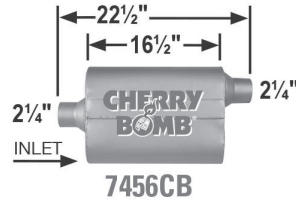

CENTER/DUAL

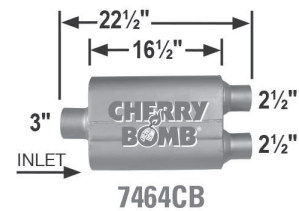
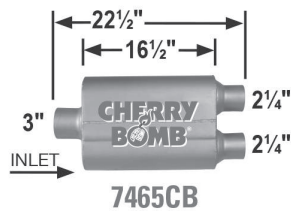

OFFSET/DUAL

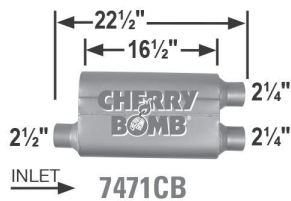

CROSS-FLOW

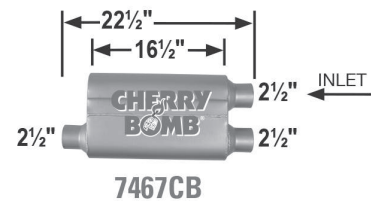

All Pro Mufflers are Directional Flow Design.
All neck sizes are inside diameter unless otherwise noted.

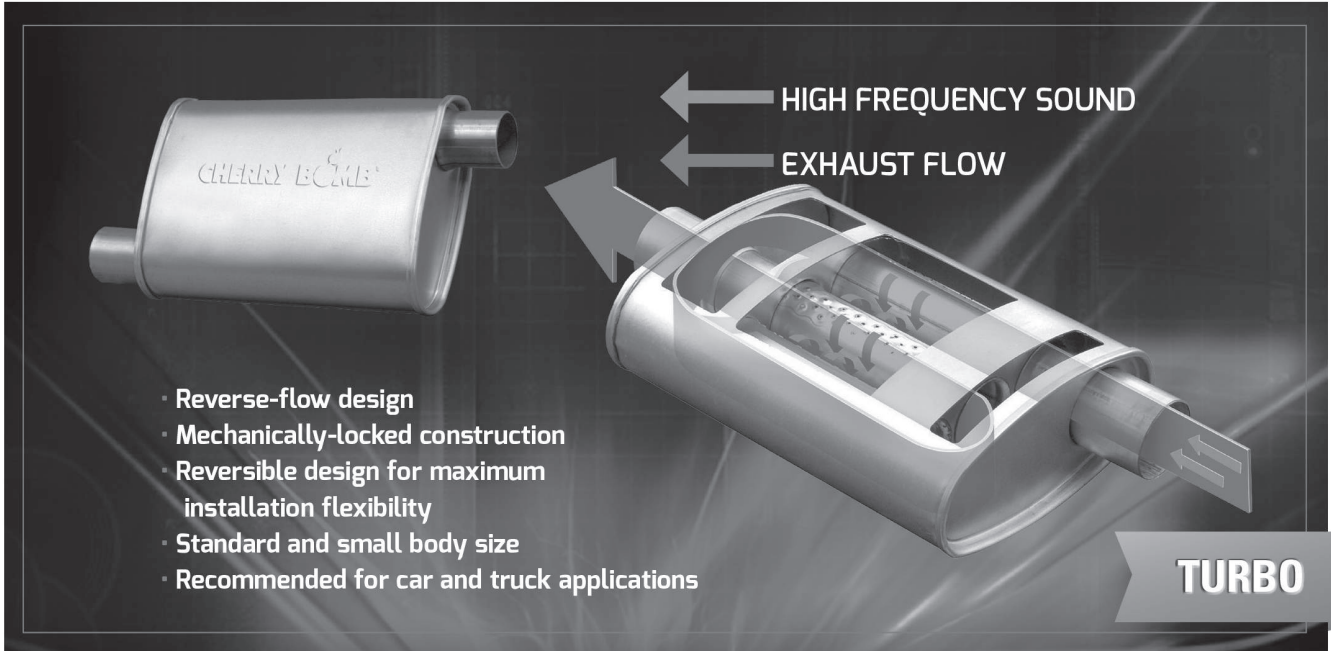

- Reverse-flow design
- Mechanically-locked construction
- Reversible design for maximum installation flexibility
- Standard and small body size
- Recommended for car and truck applications



3 1/4" x 7 3/4" OVAL

OFFSET/CENTER

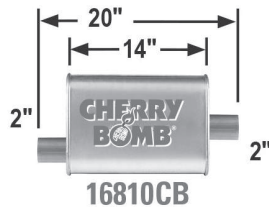

OFFSET/OFFSET

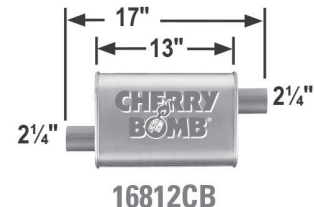
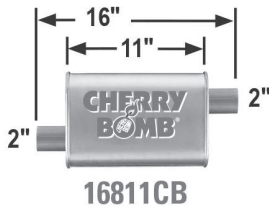

All Turbo Mufflers are Reversible.
Turbo Mufflers are Double Wrapped.
All neck sizes are inside diameter unless otherwise noted.

CHERRY BOMB® TURBO PERFORMANCE MUFFLERS



PERFORMANCE



4 1/4" x 8 3/4" OVAL

OFFSET/CENTER

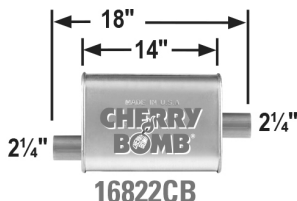
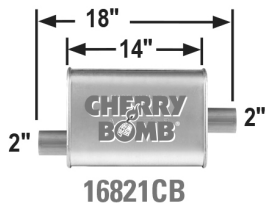

OFFSET/OFFSET

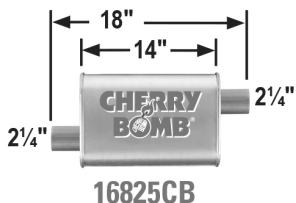
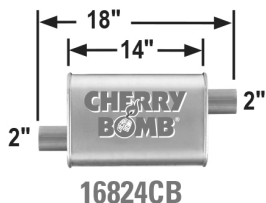

4 1/16" x 10 1/2" OVAL

OFFSET/CENTER

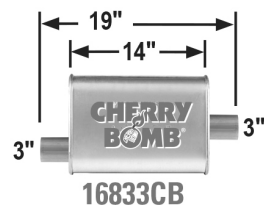
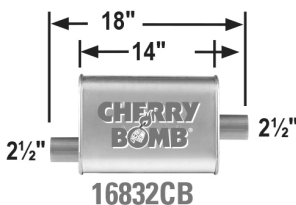

CENTER/DUAL

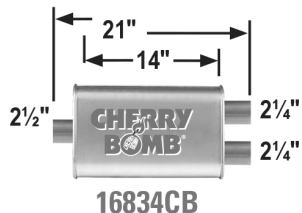

DUAL/DUAL

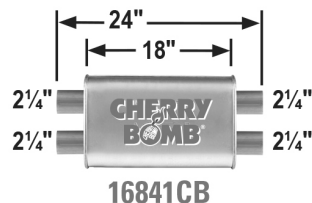

All Turbo Mufflers are Reversible.
Turbo Mufflers are Double Wrapped.
All neck sizes are inside diameter unless otherwise noted.

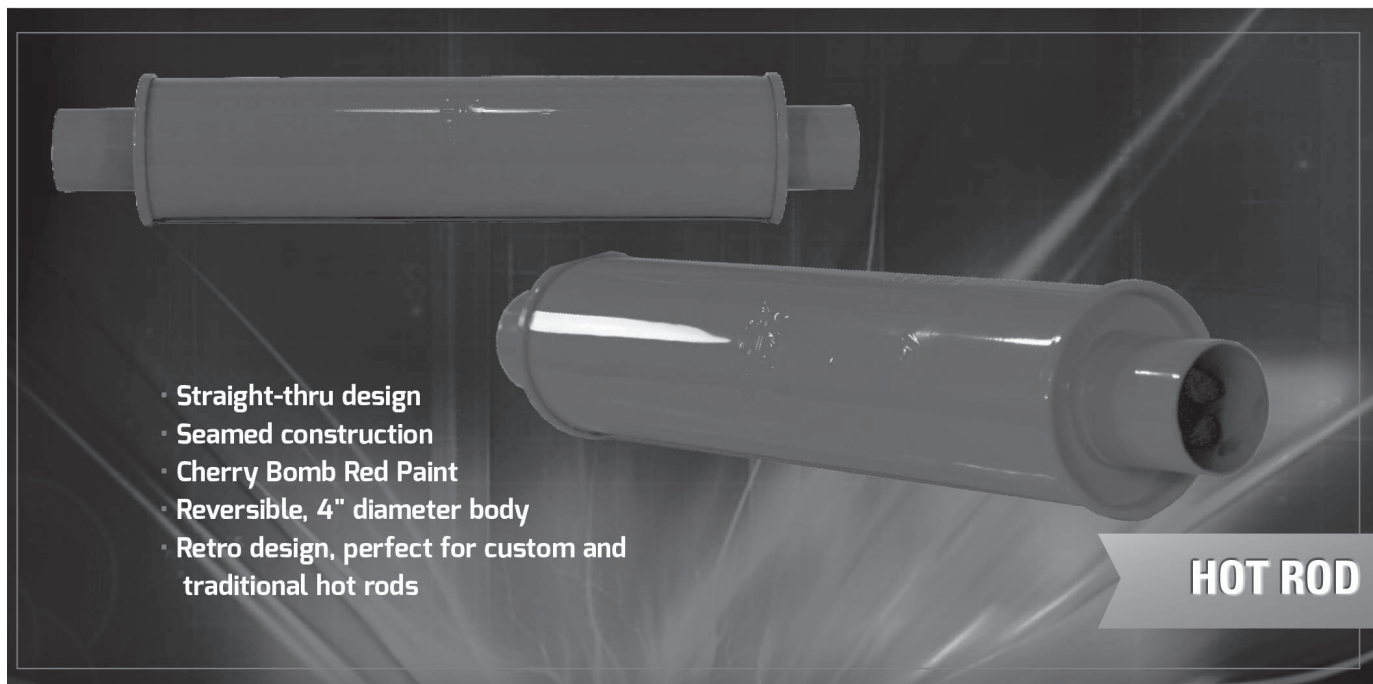
**4" DIA. Traditional Hot Rod Muffler****87886CB****87885CB**

All neck sizes are inside diameter unless otherwise noted.



X - Pipes



- Mandrel Bent
- Aluminized Steel
- Available in 3 Sizes

Universal X-Flow pipes increase horsepower and reduce noise levels. They work like an H-pipe balance tube, but give your vehicle better performance by increasing exhaust scavenging and balancing the exhaust pulses.

P/N	DIAMETER O.D.	WIDTH	LENGTH
429834CB	2 ¼"	8 ½"	18"
429835CB	2 ½"	8 ½"	18"
429836CB	3"	8 ½"	18"



UNIVERSAL Y-CONNECTORS



429825CB
429826CB



429819CB

- Aluminized Steel
- Available in 2 styles

P/N	OVERALL LENGTH	INLET DIAMETER	OUTLET DIAMETER	OUTLET CENTER TO CENTER DISTANCE
429825CB	13 ¼"	3" I.D.	Dual 2 ¼" O.D.	5 ½"
429826CB	13 ¼"	3" I.D.	Dual 2 ½" O.D.	6"
429819CB	12"	2 ¼" O.D.	Dual 2 ¼" O.D.	---



180° MANDREL U-BENDS

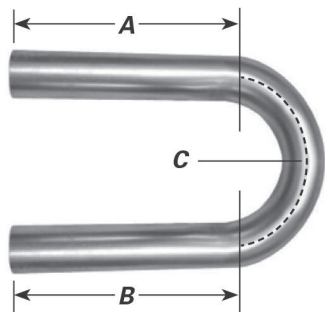

- Aluminized
- Mandrel Bent

P/N	INLET DIA. O.D.	OUTLET DIA. O.D.	LEG LENGTH (A)	LEG LENGTH (B)	CENTERLINE RADIUS (C)
320463CB	2"	2"	9"	9"	3 ½"
320464CB	2 ¼"	2 ¼"	8"	8"	4 ½"
320466CB	2 ½"	2 ½"	9"	9"	3 ½"
320465CB	2 ½"	2 ½"	8"	8"	4 ½"
320467CB	3"	3"	8"	8"	5 ½"



170° MANDREL ELBOWS

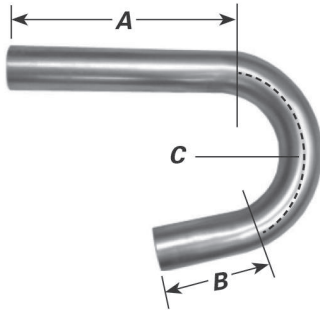

- Aluminized Steel
- Mandrel Bent

P/N	INLET DIA. O.D.	OUTLET DIA. O.D.	LEG LENGTH (A)	LEG LENGTH (B)	CENTERLINE RADIUS (C)
320474CB	2 ½"	2 ½"	14"	5"	4 ½"
320475CB	3"	3"	14"	5"	5"



90° MANDREL ELBOWS

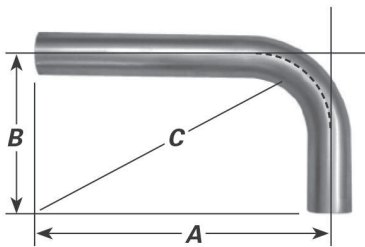

- Aluminized Steel
- Mandrel Bent

P/N	INLET DIAMETER	OUTLET DIAMETER	LEG LENGTH (A)	LEG LENGTH (B)	CENTERLINE RADIUS (C)
320441CB	2 ¼" O.D.	2 ¼" O.D.	14"	5"	4"
320442CB	2 ½" O.D.	2 ½" O.D.	14"	5"	4 ½"
320443CB	3" O.D.	3" O.D.	7"	7"	3 ½"
320444CB	3" O.D.	3" O.D.	14"	5"	5"
320445CB	3" O.D.	3" O.D.	7"	7"	5 ½"
320446CB	3 ½" O.D.	3 ½" O.D.	7"	7"	4"
320447CB	3 ½" I.D.	3 ½" I.D.	7"	7"	6"
320448CB	4" I.D.	4" I.D.	7"	7"	4 ½"
320449CB	4" I.D.	4" I.D.	7"	7"	6"
320450CB	4" I.D.	4" I.D.	7"	7"	8"
320451CB	5" I.D.	5" I.D.	7"	7"	6"



45° MANDREL ELBOWS

- Aluminized Steel
- Mandrel Bent

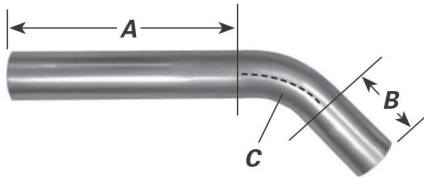

P/N	INLET DIAMETER	OUTLET DIAMETER	LEG LENGTH (A)	LEG LENGTH (B)	CENTERLINE RADIUS (C)
320452CB	2 ¼" O.D.	2 ¼" O.D.	14"	5"	4"
320453CB	2 ½" O.D.	2 ½" O.D.	14"	5"	4 ½"
320454CB	3" I.D.	3" I.D.	7"	7"	3 ½"
320455CB	3" O.D.	3" O.D.	14"	5"	5"
320456CB	3" I.D.	3" I.D.	7"	7"	5 ½"
320457CB	3 ½" I.D.	3 ½" O.D.	7"	7"	4"
320458CB	3 ½" I.D.	3 ½" I.D.	7"	7"	6"
320459CB	4" I.D.	4" I.D.	7"	7"	4 ½"
320460CB	4" I.D.	4" I.D.	7"	7"	6"
320461CB	4" I.D.	4" I.D.	7"	7"	8"



30° MANDREL ELBOWS

- Aluminized Steel
- Mandrel Bent

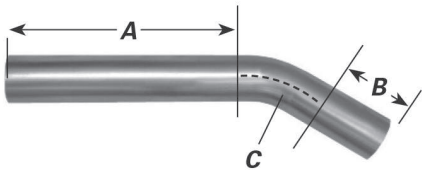

P/N	INLET DIA. O.D.	OUTLET DIA. O.D.	LEG LENGTH (A)	LEG LENGTH (B)	CENTERLINE RADIUS (C)
320462CB	3"	3"	14"	5"	5"

Sorted first by Cross Section, then Shell Length, then Inlet Diameter.

6" ROUND

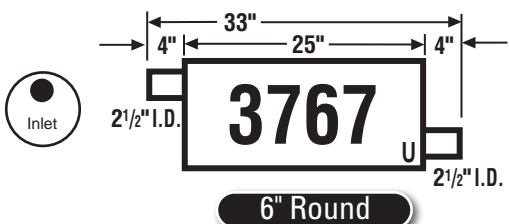
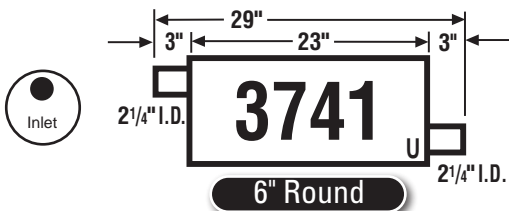
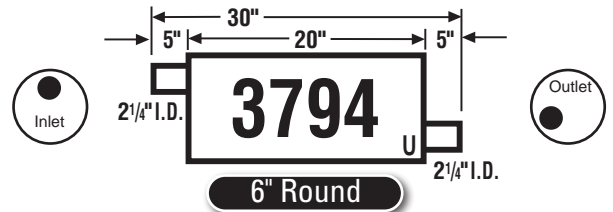
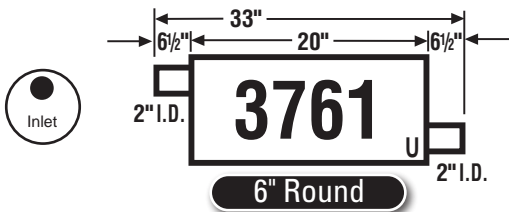
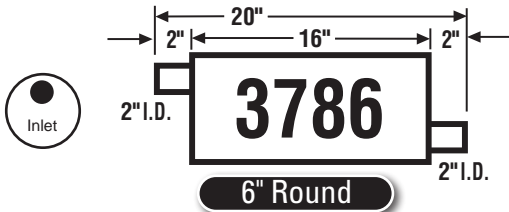
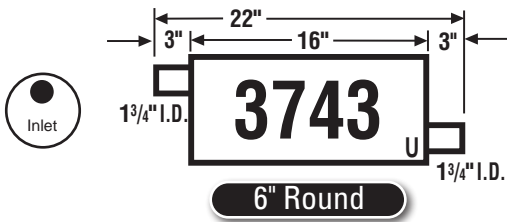

3 1/4" x 7 3/4"

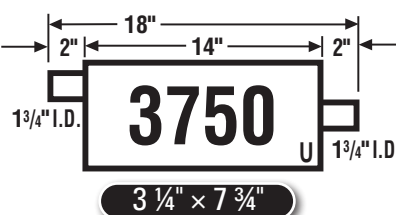
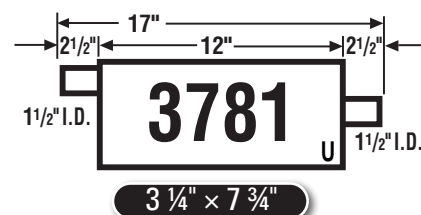

ECONOMY MUFFLERS

Sorted first by Cross Section, then Shell Length, then Inlet Diameter.

ENFORCER II®

4 1/4" x 8 3/4"

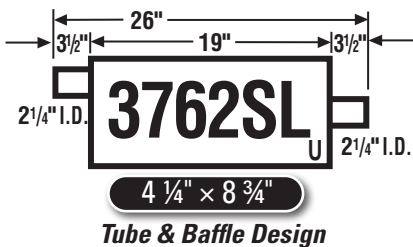
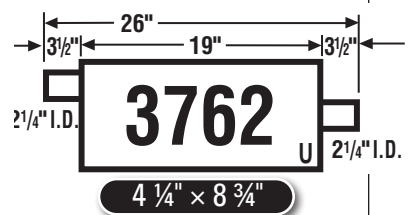
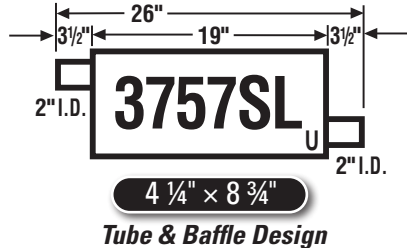
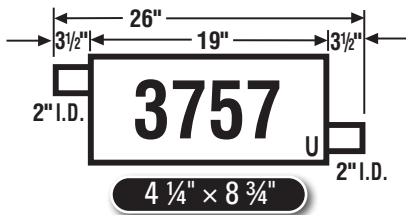
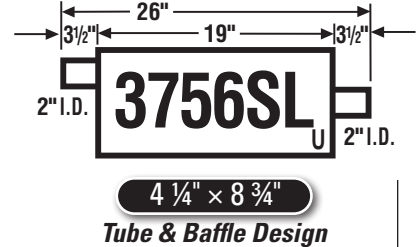
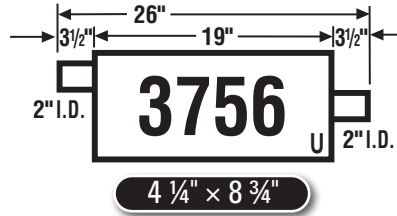
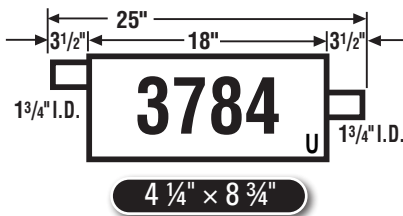
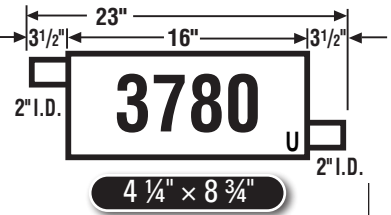
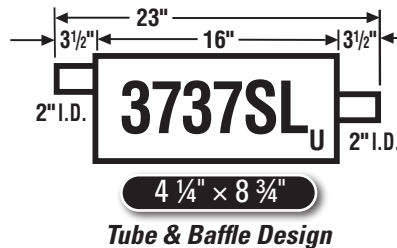
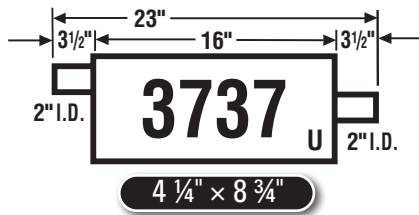
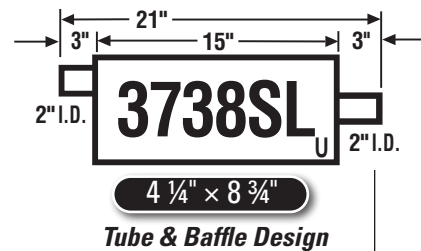
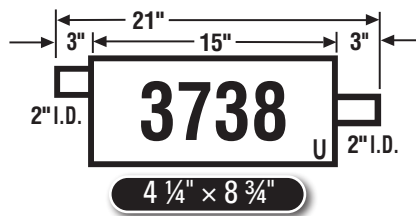
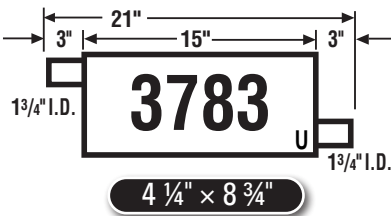
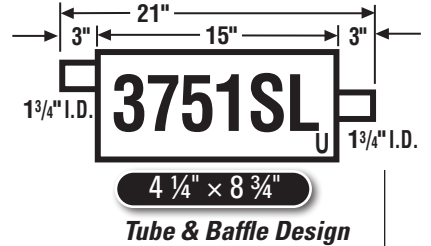
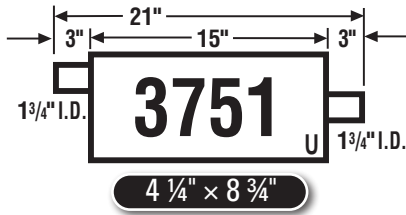
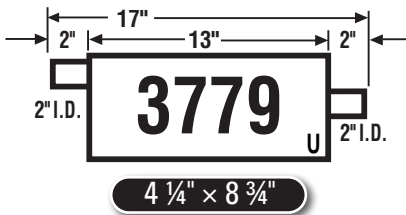

ENFORCER MUFFLERS BY DIMENSION

4 1/16" x 10 1/2"

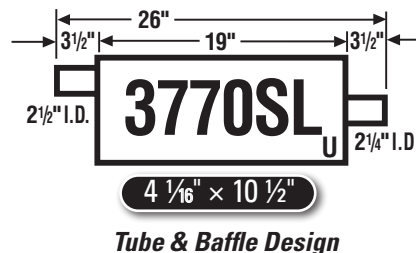
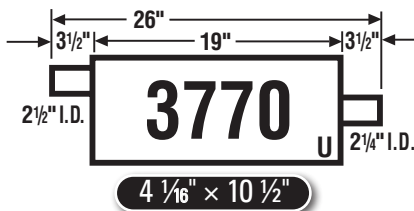
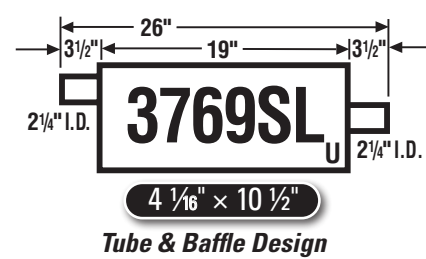
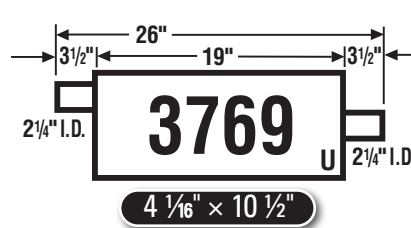
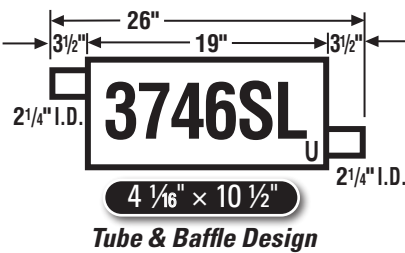
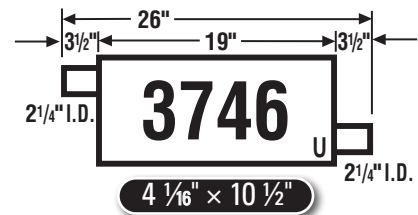
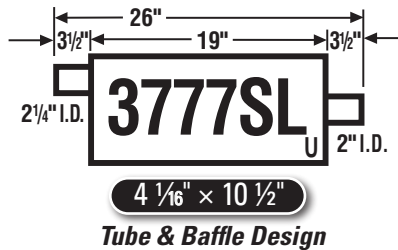
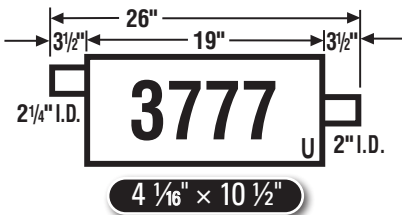
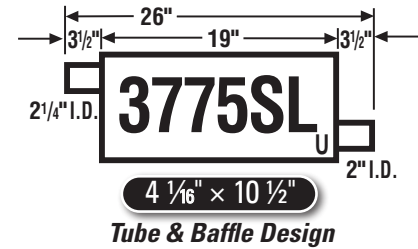
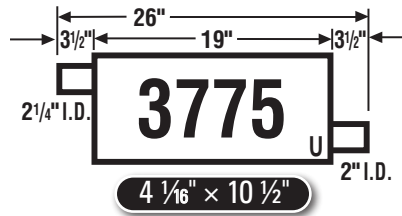
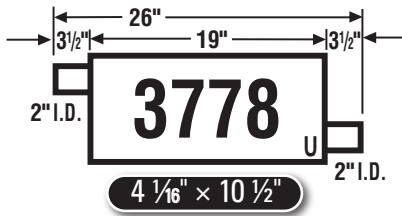
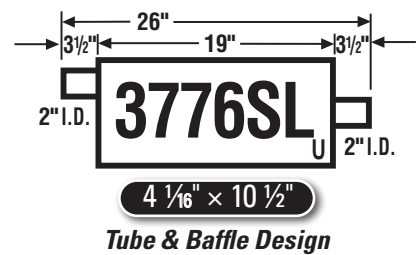
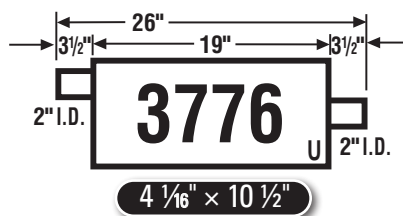
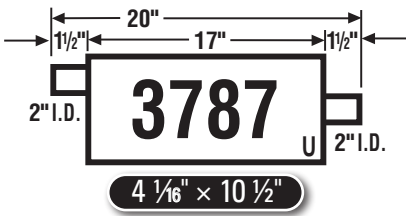

ENFORCER MUFFLERS BY DIMENSION

ECONOMY MUFFLERS

ENFORCER II®

7" x 9"

360° WELDED NECKS

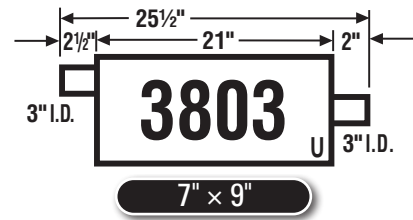
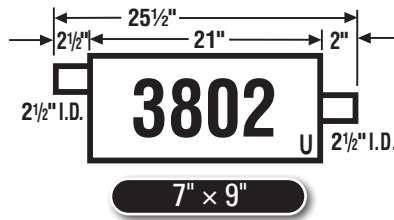
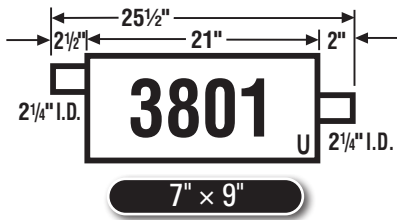

7" Round

360° WELDED NECKS

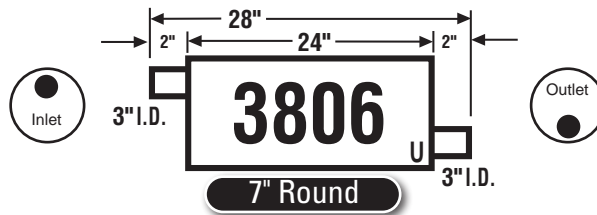
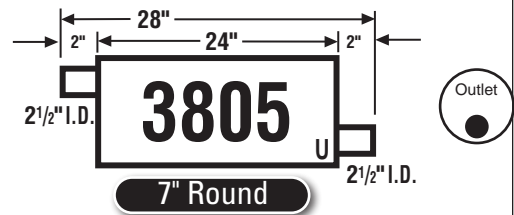
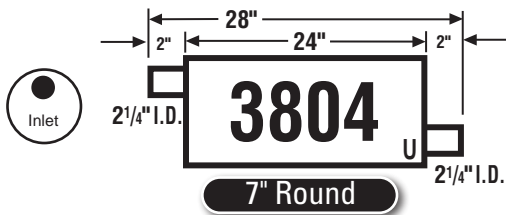

ENFORCER MUFFLERS BY DIMENSION

HEAVY DUTY TRUCK MUFFLERS

UNIVERSAL ALL WELDED ALUMINIZED HEAVY DUTY TRUCK MUFFLERS

- 100% Aluminized
- All Welded Construction
- Light Truck & Medium Duty Truck Applications

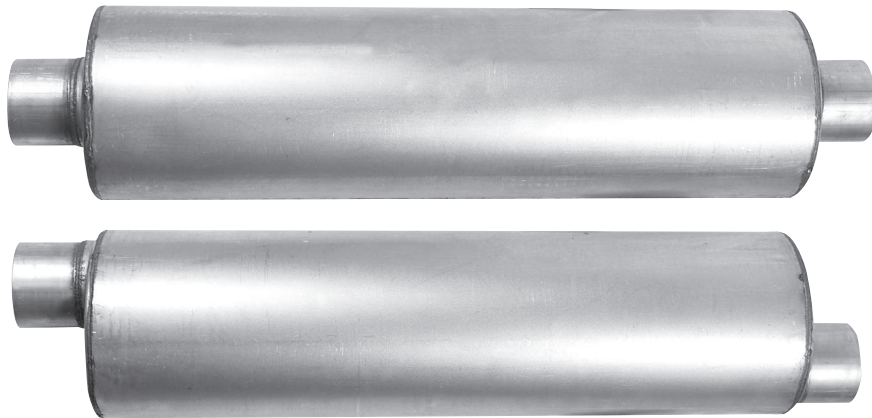

P/N	DIAMETER	SHELL LENGTH	OVERALL LENGTH	INLET/OUTLET	NECKS
4267	7" Round	26"	32"	Center/Center	2 ¼"
4268	7" Round	26"	32"	Center/Center	2 ½"
4269	7" Round	26"	32"	Center/Center	3"
4270	7" Round	26"	32"	Center/Center	3 ½"
4271	7" Round	26"	32"	Offset/Offset	2 ¼"
4272	7" Round	26"	32"	Offset/Offset	2 ½"
4273	7" Round	26"	32"	Offset/Offset	3"
4274	7" Round	26"	32"	Offset/Offset	3 ½"

GENERATOR MUFFLER

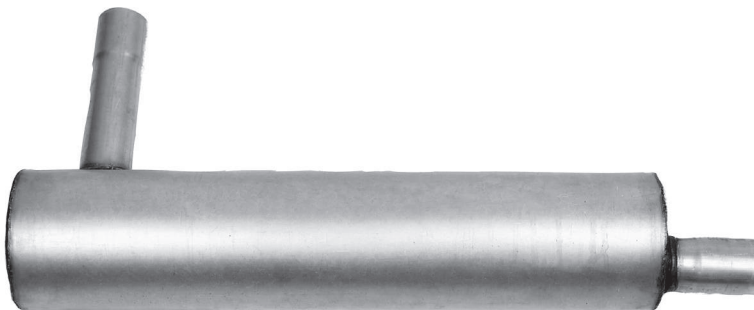

P/N	DIAMETER	SHELL LENGTH	OVERALL LENGTH	INLET LENGTH	INLET/OUTLET	NECKS
4290	4" Round	18"	21"	6"	Side/Offset	1 ½"

FLEX & REPAIR

EXHAUST PIPES Sorted from Newest to Oldest Application

CHRYSLER/DODGE/PLYMOUTH

121683

Inlet - 4 Bolt Flange
Outlet - 2 ½" O.D.
O.A.L. - 6"
Gasket 9289



- 00-05 DODGE/PLYM Neon 2.0L
- 96-10 CHRYS Town & Country,
DODGE Caravan Plymouth Voyager 3.3L & 3.8L
- 01-03 CHRYS Voyager 2.4L
- 01-07 DODGE Caravan 2.4L
- 01-10 CHRYS PT Cruiser 2.4L
- 05-08 CHRYS Pacifica 3.8L

With Inner Lock Flex (Inner Heat Shield)

121681

Inlet - 4 Bolt Flange
Outlet - 2 ¼" O.D.
O.A.L. - 8 ½"
Gasket 9289



- 95-06 CHRYS Cirrus, Sebring 2.4L & 2.5L
- 95-06 DODGE Stratus 2.0L, 2.4L & 2.5L
- 98-00 PLYM Breeze 2.0L & 2.4L

FORD/LINCOLN/MERCURY

121690

Inlet - 2 Bolt Flange
Outlet - 2" I.D.
O.A.L. - 5 7/16"
Gasket 9059



- 00-07 FORD Taurus 3.0L
- 96-98 MERC Sable 3.0L

With Inner Braid

121685

Inlet - 4 Bolt Flange
Outlet - 3" O.D.
O.A.L. - 9 ½"
Gasket 9245



- 87-95 FORD Truck E-Series
- 87-99 FORD Truck F-Series

FLEX & REPAIR

EXHAUST PIPES Sorted from Newest to Oldest Application

GENERAL MOTORS

121691

Inlet - 3 Bolt Flange
Outlet - 2 3/32" I.D.
O.A.L. - 4"
Gasket 8403

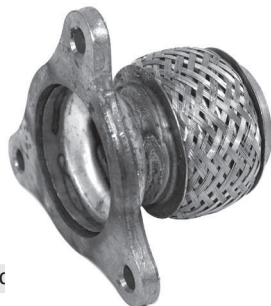

- 02-05 CHEV/PONT Cavalier/Sunfire 2.2L (02 Coc
- 05-10 CHEV Cobalt 2.2L
- 06-08 CHEV Cobalt 2.4L
- 06-11 CHEV HHR 2.2L & 2.4L
- 04-05 CHEV Malibu Classic 2.2L
- 02-04 OLDS Alero 2.2L

With Inner Braid Flex

- PONTIAC G5 2.2L & 2.4L
- PONTIAC Grand Am 2.2L

- 03-07 SATURN Ion 2.2L
- 06-07 SATURN Ion 2.4L
- 01-04 SATURN L100 L200 LW200 2.2L A/T
- 02-06 SATURN Vue 2.2L

121692

Inlet - 3 Bolt Flange
Outlet - 2 1/2" I.D.
O.A.L. - 7 1/2"
Gasket 8762

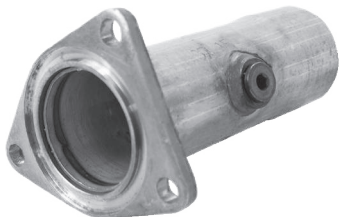

- 99-06 GM Truck 4.3L Engine Left
- 99-05 GM Truck 4.8L Engine Left
- 99-05 GM Truck 5.3L Engine Left

122621

Inlet - 2 Bolt Flange
Outlet - 2 9/16" O.D.
O.A.L. - 19 1/2"
Gasket 9088



- 97-04 BUICK Regal 3.8L
- 00-05 CHEV Impala, Monte Carlo 3.8L
- 98-99 OLDS Intrigue 3.8L
- 97-03 PONT Grand Prix 3.8L

With Inner Braid Flex

123532

Inlet - 2 Bolt Flange
Outlet - 2 1/4" O.D.
O.A.L. - 25"
Gasket 8762



- 98-03 CHEV Malibu 3.1L
- 99-04 OLDS Alero 3.4L
- 98-99 OLDS Cutlass 3.1L
- 99-04 PONT Grand Am 3.4L

With Inner Braid Flex

122624

Inlet - 2 Bolt Flange
Outlet - 2 1/4" O.D.
O.A.L. - 20 1/2"
Gasket 8762



- 97-04 BUICK Century 3.1L
- 00-04 CHEV Impala, Monte Carlo 3.4
- 97-01 CHEV Lumina 3.1L
- 97-04 PONT Grand Prix 3.1L

FLEX & REPAIR

EXHAUST PIPES Sorted from Newest to Oldest Application

GENERAL MOTORS

121688

Inlet - 3 Bolt Flange
 Outlet - 1 3/4" I.D.
 O.A.L. - 4 1/2"
 Gasket 8731



- 98-03 CHEV S10 Pickup 2.2L
- 98-03 GMC S15 Sonoma Pickup 2.2L

With Inner Braid Flex

122618

Inlet - 3 Bolt Flange
 Outlet - 2" O.D.
 O.A.L. - 23 1/2"
 Gasket 9207



- 99-02 CHEV Cavalier 2.4L
- 99-00 CHEV Malibu 2.4L
- 99-01 PONT Grand Am 2.4L
- 99-02 PONT Sunfire 2.4L
- 99-01 OLDS Alero 2.4L

122622

Inlet - 2 Bolt Flange
 Outlet - 2 1/4" O.D.
 O.A.L. - 23 1/2"
 Gasket 8762



- 2001 CHEV Venture 3.4L
- 2001 OLDS Silhouette 3.4L
- 2001 PONT Montana 3.4L

123530

Inlet - 2 Bolt Flange
 Outlet - 2 1/4" O.D.
 O.A.L. - 26 1/2"
 Gasket 8762

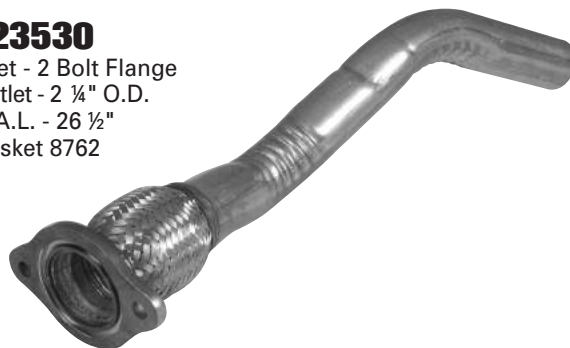

- 97-00 CHEV Venture 3.4L
- 97-00 OLDS Silhouette 3.4L
- 99-00 PONT Montana 3.4L
- 97-98 PONT Transport 3.4L

121686

Inlet - 4 Bolt Flange
 Outlet - 1 3/4" I.D.
 O.A.L. - 4 1/4"
 Gasket 9054



- 96-98 BUICK Skylark 2.4L
- 96-98 CHEV Cavalier, 97-98 Malibu 2.4L
- 96-98 OLDS Achieva 2.4L
- 96-98 PONT Grand Am, Sunfire 2.4L

With Inner Braid Flex

VOLKSWAGEN

121689

Inlet - 6 Bolt, Dual Inlet Flange
 Outlets - 1 3/4" I.D.
 O.A.L. - 3 3/4"
 Gasket 9213



- 87-92 VW Jetta & Golf 1.8L
- 98-01 VW Beetle 2.0L AEG Eng
- 99-01 VW Golf 2.0L AEG Eng
- 99-01 VW Jetta 2.0L AEG Eng

- Max Fit consists of Universal, Direct Fits, and Dual Conversion Pipes.
- Max Fit Universal Pre-bent Pipe is designed especially for the professional installer who has a pipe bender. With Max Fit Pipes, all of the tough bends have already been made. Just turn the outlet end down to either side, or cut it off — depending on the application. Job times are cut in half, the fit is always perfect and there is never any wasted material.
- Save time, space and money with the Max Fit line.
- All Max Fit pipes are 100% aluminized and produced using heavy 14-16 gauge O.D. steel, and re-aluminized weld seams to prevent corrosion.
- Premium Mandrel—bent pipe options maximize gas flow and product life.
- Selected Mandrel pipes are also available in 409 stainless steel.

CHRYSLER CORP. — CHRYSLER/DODGE/JEEP/PLYMOUTH/RAM

MAX FIT

RH: **126656** (2 1/2")

LH: **126657** (2 1/2")



04-08 DODGE Dakota, All Engs., Club Cab & Quad Cab 131" WB; Dual Conversion

MAX FIT

RH: **126660** (2 1/2")

LH: **126661** (2 1/2")

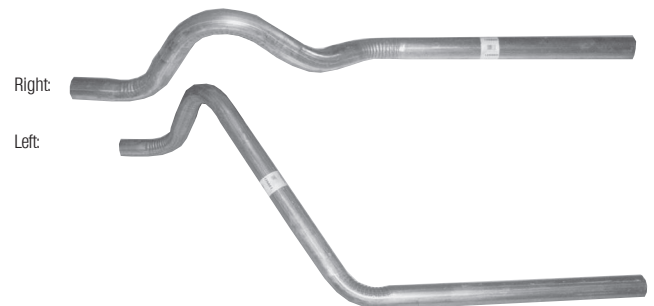

00-03 DODGE Dakota, All Engs., Club Cab & Quad Cab 112", 131" WB; Dual Conversion

MAX FIT

RH: **127596** (2 1/2")

LH: **127595** (2 1/2")



87-99 DODGE Dakota; 6 & 8 Cyl; All WB, Dual Conversion

MANDREL

RH: **X6005** (2 1/2")
112" & 131" WB

LH: **X6006** (2 1/2")
112" & 131" WB

MANDREL

RH: **X7041** (2 1/2")
w/OE DUALS

RH: **X7043** (2 1/2")
w/out OE DUALS

MANDREL

LH: **X8006** (2 1/2")
w/OE DUALS

LH: **X8007** (2 1/2")
w/out OE DUALS



11-12 RAM 1500; 3.7L, 4.7L, 5.7L, Dual Conversion

09-10 DODGE RAM 1500; 3.7L, 4.7L, 5.7L, Dual Conversion

PROFESSIONAL INSTALLER PIPES

Sorted by Manufacturer, then Model,
then from Newest to Oldest Application

MAX FIT[®]

with Mandrel Options

CHRYSLER CORP. — CHRYSLER/DODGE/JEEP/PLYMOUTH/RAM

MAX FIT

RH: **127694** (2 1/2")

LH: **128678** (2 1/2")

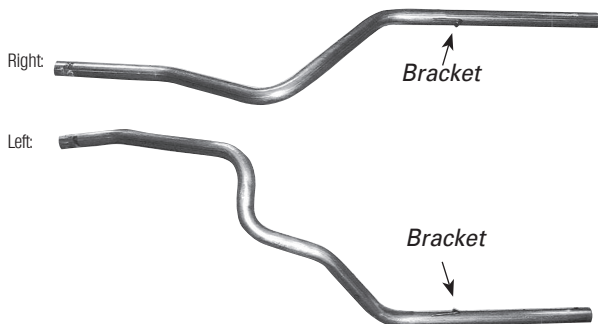

2009 DODGE Ram 1500, 5.7L Eng., 140.5" WB; with OE Duals

MAX FIT

RH: **128010** (2 1/4")

RH: **128012** (2 1/2")

LH: **128009** (2 1/4")

LH: **128011** (2 1/2")

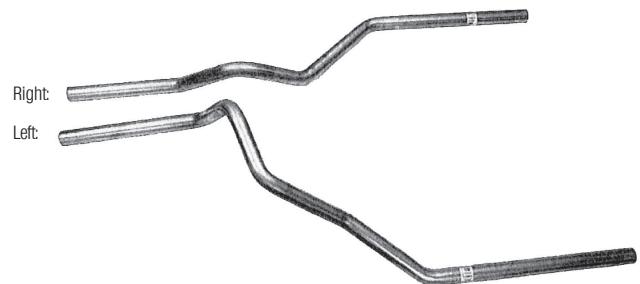

07-08 DODGE Ram Pickup

Pipe Also Fits Ford & Chev./GMC Trucks

MANDREL

RH: **X8010** (2 1/4")

RH: **X8012** (2 1/2")

RH: **XSX8012** (2 1/2")
STAINLESS STEEL

LH: **X8009** (2 1/4")

LH: **X8011** (2 1/2")

LH: **XSX8011** (2 1/2")
STAINLESS STEEL

MAX FIT

RH: **127688** (2 1/2")

LH: **127687** (2 1/2")

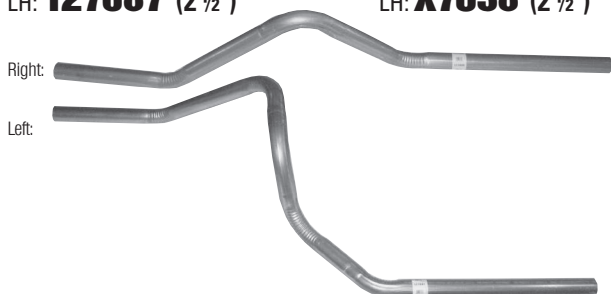

06-08 DODGE Ram 1500, 3.7L, 4.7L, 5.7L Eng., 120", 140" WB; Dual Conversion

MANDREL

RH: **X7039** (2 1/2")

LH: **X7038** (2 1/2")

MAX FIT

RH: **127681** (2 1/4")

LH: **127682** (2 1/4")

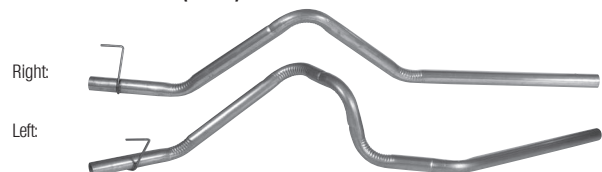

02-05 DODGE Ram 1500/2500 (Under 8800 lbs. GVW); 6 & 8 Cyl; 3.7L, 4.7L; 120" WB; Dual Conversion

CHRYSLER CORP. — CHRYSLER/DODGE/JEEP/PLYMOUTH/RAM

MAX FIT

RH: **127676** (2 1/4")

LH: **128677** (2 1/4")

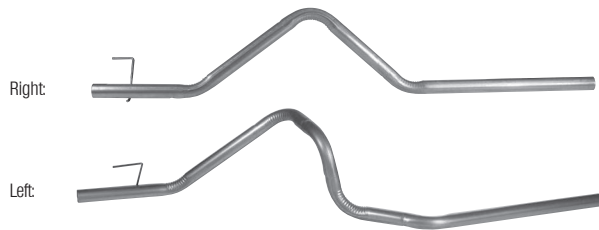

02-05 DODGE Ram 1500/2500 (Under 8800 lbs. GVW);
6 & 8 Cyl; 3.7L, 4.7L Eng., 03-05 5.7L Hemi Eng.,
02-03 5.9L Eng.; 140" WB; Dual Conversion

MAX FIT

RH: **126102** (2 1/4")

RH: **126104** (2 1/2")

LH: **126103** (2 1/4")

LH: **126105** (2 1/2")



87-04 DODGE Ram 1500/2500; Dual Conversion

Pipe Also Fits Ford & Chev./GMCTrucks

MANDREL

RH: **X6102** (2 1/4")

RH: **X6104** (2 1/2")

LH: **X6103** (2 1/4")

LH: **X6105** (2 1/2")

MANDREL

54997 (4")



94-02 DODGE Ram 2500/3500 6 Cyl; 5.9L Cummins Turbo
Diesel; ALL W.B.

MAX FIT

RH: **128594** (2 1/2")

LH: **128593** (2 1/2")

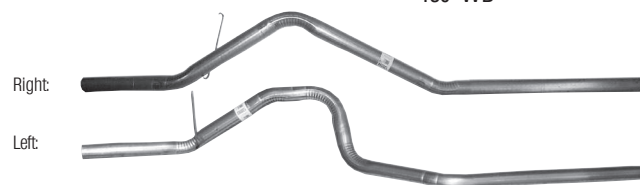

94-01 DODGE Ram 1500/2500 (Under 8800 lbs. GVW);
6 & 8 Cyl; 3.9L, 5.2L, 5.9L; 119", 135", 139" WB; Dual
Conversion

MANDREL

RH: **X7002** (2 1/2")

139" WB

LH: **X7001** (2 1/2")

139" WB

MAX FIT

RH: **128663** (2 1/4")

LH: **128662** (2 1/4")

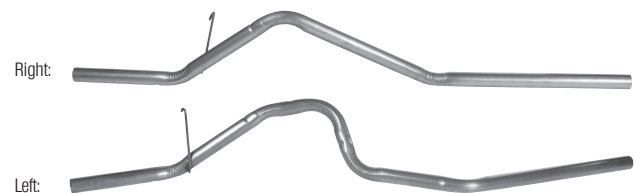

94-01 DODGE Ram 1500/2500 (Under 8800 lbs. GVW);
6 & 8 Cyl; 3.9L, 5.2L, 5.9L; 119", 135", 139" WB;
Dual Conversion

PROFESSIONAL INSTALLER PIPES

Sorted by Manufacturer, then Model,
then from Newest to Oldest Application

MAX FIT[®]

with Mandrel Options

CHRYSLER CORP. — CHRYSLER/DODGE/JEEP/PLYMOUTH/RAM

MANDREL
X6007 (3")

XSX6007 (3")
Stainless Steel



88-01 DODGE Full Size, Light-Duty Trucks, 8 Cyl.

Pipe Also Fits Chev./GMC, & Ford Full-Sized Light-Duty Trucks

MANDREL
X4001 (2 1/4")



97-06 JEEP Wrangler, 4-6 Cyl. All Eng

FORD MOTOR CO. — FORD/LINCOLN/MERCURY

MAX FIT

RH: **126555** (2")
LH: **126582** (2")



- 83-88 FORD Crown Victoria Sedan
- 80-82 FORD LTD Sedan
- 82-88 LINC Town Car
- 80-83 LINC Continental, Mark VI
- 83-88 MERC Grand Marquis Sedan
- 80-82 MERC Marquis Sedan

MAX FIT

RH: **127686** (2 1/4")
LH: **127685** (2 1/4")

MANDREL

RH: **X7035** (2 1/4")
LH: **X7034** (2 1/4")

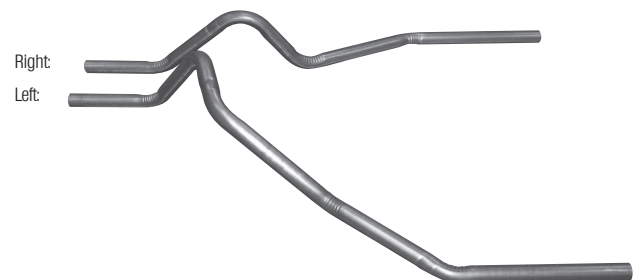

- 04-14 FORD F150 (New Body Style); 8 Cyl; 3.5L Turbo; 4.6L, 5.0L; 5.4L; All WB; Dual Conversion
- 06-08 LINC Mark LT; 8 Cyl; 5.4L, 139" WB; Dual Conversion

FORD MOTOR CO. — FORD/LINCOLN/MERCURY

MAX FIT

RH: **126672** (2 1/4")

LH: **127697** (2 1/4")

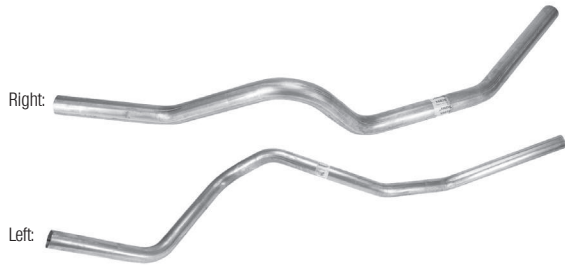

04-14 FORD F150 6 Cyl; 8 Cyl; 3.5L Turbo; 4.6L, 5.0L; 5.4L; Dual Conversion; 45 Degree Side Exit

MANDREL

RH: **X6026** (2 1/4")

LH: **X7047** (2 1/4")

MAX FIT

RH: **128010** (2 1/4")

RH: **128012** (2 1/2")

LH: **128009** (2 1/4")

LH: **128011** (2 1/2")

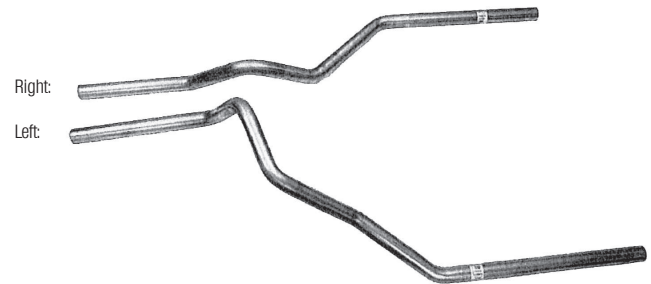

07-11 FORD F-Series Pickup

Pipe Also Fits Dodge & Chev./GMC Trucks

MANDREL

RH: **X8010** (2 1/4")

RH: **X8012** (2 1/2")

RH: **XSX8012** (2 1/2")
STAINLESS STEEL

LH: **X8009** (2 1/4")

LH: **X8011** (2 1/2")

LH: **XSX8011** (2 1/2")
STAINLESS STEEL

MANDREL

54994 (4")



99-03 FORD F250/F350 Super Duty, 7.3L Diesel Engine, OAL 61"

MANDREL

X5014 (4")



99-03 FORD F250/F350 Super Duty, 7.3L Diesel Engine, OAL 51"

MAX FIT

RH: **127666** (2 1/4")

LH: **128667** (2 1/4")

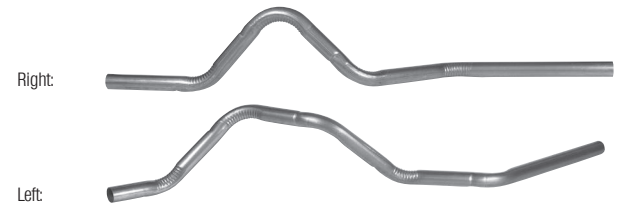

02-03 FORD F150/F250 (Under 8800 lbs. GVW); 6 & 8 Cyl; 4.2L, 4.6L, 5.4L; 120", 139" WB; Dual Conversion

PROFESSIONAL INSTALLER PIPES

Sorted by Manufacturer, then Model,
then from Newest to Oldest Application

MAX FIT[®]

with Mandrel Options

FORD MOTOR CO. — FORD/LINCOLN/MERCURY

MAX FIT

RH: **126102** (2 1/4")
RH: **126104** (2 1/2")

LH: **126103** (2 1/4")
LH: **126105** (2 1/2")

MANDREL

RH: **X6102** (2 1/4")
RH: **X6104** (2 1/2")

LH: **X6103** (2 1/4")
LH: **X6105** (2 1/2")

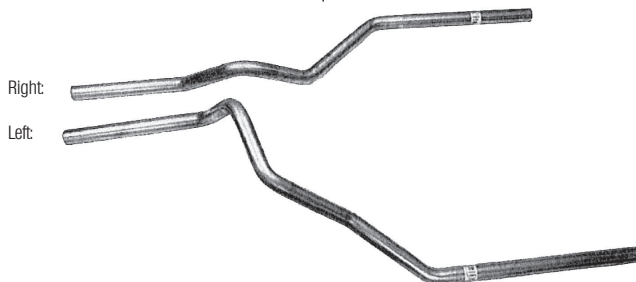

87-02 FORD F Series; Dual Conversion

Pipe Also Fits Dodge & Chev./GMC Trucks

MAX FIT

RH: **127657** (2 1/4")
RH: **127633** (2 1/2")

LH: **127656** (2 1/4")
LH: **127632** (2 1/2")

MANDREL

RH: **X7012** (2 1/2")

LH: **X7011** (2 1/2")

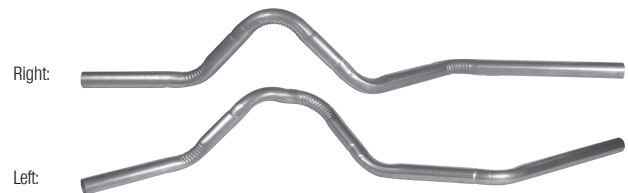

97-01 FORD F150/F250 (Under 8800 lbs. GVW); 6 & 8 Cyl;
4.2L, 4.6L, 5.4L; 120", 139" WB; Dual Conversion

MANDREL

X6007 (3")
XSX6007 (3")
STAINLESS STEEL



88-97 FORD Full Size, Light-Duty Trucks, 8 Cyl.

Pipes Also Fit Chev./GMC & Dodge Full-Sized Light Duty Trucks

MAX FIT

RH: **126653** (2 1/2")

LH: **127689** (2 1/2")

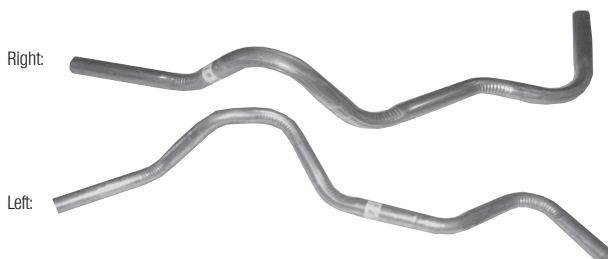

97-01 FORD F150/F250 (Under 8800 lbs. GVW); 4.2L,
4.6L, 5.4L Eng., 120", 139" WBs with 90 Degree
Side Exit; Dual Conversion

MAX FIT

RH: **127580** (2 1/4")

LH: **127581** (2 1/4")



87-96 FORD F150/F250 (Under 8500 lbs. GVW); 6 & 8 Cyl;
4.9L, 5.0L, 5.8L; 116", 133", 139" WB;
Dual Conversion

FORD MOTOR CO. — FORD/LINCOLN/MERCURY

MAX FIT

125568 (2 1/4")



83-86 FORD F Series; 6 & 8 Cyl.
87-97 FORD F350; 6 Cyl.

MAX FIT

RH: **126615** (2")

LH: **127614** (2")



93-00 FORD Ranger; 4 & 6 Cyl; 2.3L, 2.5L, 3.0L, 4.0L;
All WB; Dual Conversion

Pipes Also Fit Mazda B-Series Trucks

MAX FIT

RH: **126301** (2 1/4")

RH: **126303** (2 1/2")

LH: **126302** (2 1/4")

LH: **126304** (2 1/2")

MANDREL

RH: **X6301** (3")

LH: **X6302** (3")

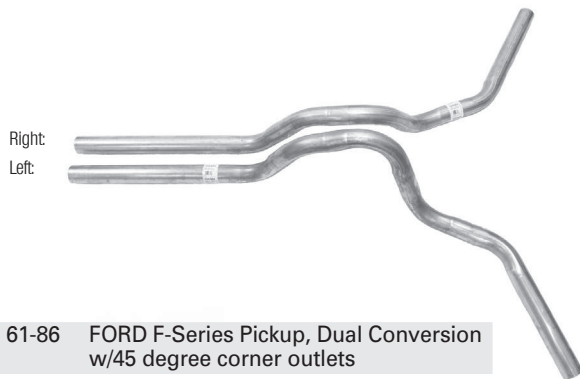

61-86 FORD F-Series Pickup, Dual Conversion
w/45 degree corner outlets

Pipes Also Fit Chev./GMC Trucks

MANDREL

RH: **X5123** (2 1/2")

LH: **X5122** (2 1/2")



96-98 FORD Mustang

MAX FIT

RH: **125636** (2 1/4")

LH: **125637** (2 1/4")

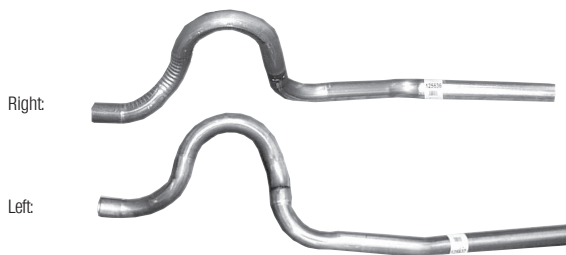

84-04 FORD Mustang, GT, LX

MANDREL

RH: **X5003** (2 1/2")

LH: **X5002** (2 1/2")



87-93 FORD Mustang, GT 8 Cyl, 5.0L

PROFESSIONAL INSTALLER PIPES

Sorted by Manufacturer, then Model,
then from Newest to Oldest Application

MAX FIT[®]

with Mandrel Options

FORD MOTOR CO. — FORD/LINCOLN/MERCURY

MAX FIT

125564 (2")



83-92 FORD Ranger; 4 & 6 Cyl.

GENERAL MOTORS — BUICK/CHEV/GMC/OLDSMOBILE/PONTIAC

MAX FIT

126546 (2 1/4")



88-90 GM Century, 6000 Sedan; 4 Cyl.
85-90 GM Century, Cutlass Ciera; 6 Cyl.
88-89 CHEV Celebrity Sedan; 4 Cyl.
86-89 CHEV Celebrity Eurosport; 6 Cyl.
88-90 OLDS Cutlass Ciera Sedan; 4 Cyl.
86-90 PONT 6000 S/E, STE; 6 Cyl.

MAX FIT

126558 (2")



86-87 BUICK Century; 4 Cyl.
86-87 CHEV Celebrity; 4 Cyl.
86-87 OLDS Cutlass Ciera; 4 Cyl.
86-87 PONT 6000; 4 Cyl.

MAX FIT

126543 (2")



86-87 GM Century, 6000 Sedan, Cutlass Ciera; 4 Cyl.
84-86 BUICK Century; 6 Cyl.
86-87 CHEV Celebrity; 4 Cyl.
84-86 CHEV Celebrity Eurosport; 6 Cyl.
84-86 OLDS Cutlass Ciera; 6 Cyl.
83-86 PONT 6000, 6000 STE, Sedan; 6 Cyl.

MAX FIT

127553 (2")



Flare

78-87 BUICK Century, Regal
78-83 CHEV Chevelle, Malibu, Monte Carlo
78-87 OLDS Cutlass, Vista Cruiser
78-87 PONT Bonneville, Grand AM, Grand Prix, LeMans

MAX FIT

RH: **126640** (2 1/4")

LH: **126641** (2 1/4")

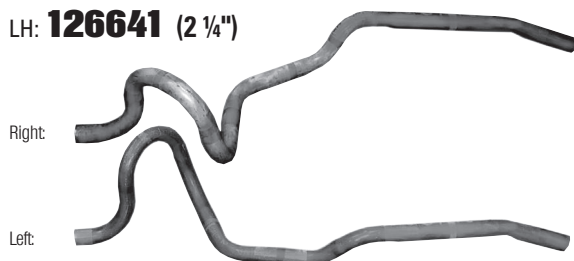

Right:

Left:

94-96 BUICK Roadmaster Sedan; Resonator Eliminator
94-96 CHEV Caprice Sedan; Resonator Eliminator

MANDREL

RH: **X5034** (2 1/2")

LH: **X5033** (2 1/2")



Right:

Left:

64-77 GM Chevelle, Skylark, Cutlass, Lemans,
Dual Conversion

PIPES

GENERAL MOTORS — BUICK/CHEV/GMC/OLDSMOBILE/PONTIAC

MAX FIT

RH: **126664** (2 1/4") w/out last 2 bends
RH: **126666** (2 1/2") w/out last 2 bends

LH: **126663** (2 1/4") w/out last 2 bends
LH: **126665** (2 1/2") w/out last bend

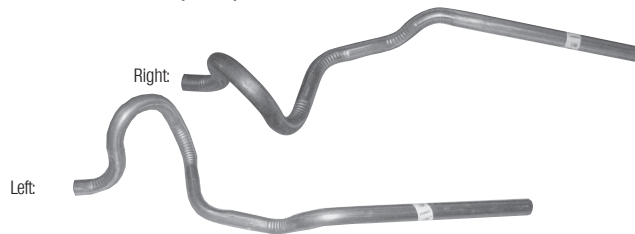

94-96 BUICK/CHEV Roadmaster, Caprice, Impala SS

MAX FIT

126554 (2")



77-85 BUICK Full Size
77-90 CAD Full Size
77-88 CHEV Full Size
77-85 OLDS Full Size
77-86 PONT Full Size

MAX FIT

RH: **126563** (2")

LH: **126508** (2")



77-90 GM Full Size
64-72 GM Mid Size

MAX FIT

126642 (2 1/4")



82-92 CHEV/PONT Camaro, Firebird; 8 Cyl.



**MANDREL
X5500** (3")

96-02 CHEV Camaro/Firebird 8 Cyl, 350, 5.7L
1995 CHEV Camaro/Firebird 8 Cyl, 350, 5.7L California Only

PROFESSIONAL INSTALLER PIPES

Sorted by Manufacturer, then Model,
then from Newest to Oldest Application

MAX FIT[®]

with Mandrel Options

GENERAL MOTORS — BUICK/CHEV/GMC/OLDSMOBILE/PONTIAC

MANDREL
X6500 (3")



89-92 CHEV Camaro/Firebird 8 Cyl, 350 F, 5.0L with two (2) catalytic converters

MAX FIT

RH: **126669 (2 1/2")**

LH: **126668 (2 1/2")**

MANDREL

RH: **X6023 (2 1/2")**

LH: **X6022 (2 1/2")**

Right:

Left:



14 -16 CHEV/GMC Silverado/Sierra 1500; 6 & 8 Cyl, 4.3L, 5.3L, 6.2L; Dual Conversion

MAX FIT

RH: **126688 (2 1/4")**

LH: **126687 (2 1/4")**

Right:

Left:

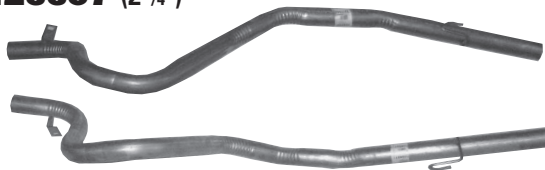

83-88 CHEV Monte Carlo SS 5.0L, VIN 7 & G

MAX FIT

RH: **128010 (2 1/4")**

RH: **128012 (2 1/2")**

LH: **128009 (2 1/4")**

LH: **128011 (2 1/2")**

MANDREL

RH: **X8010 (2 1/4")**

RH: **X8012 (2 1/2")**

RH: **XSX8012 (2 1/2")**
STAINLESS STEEL

LH: **X8009 (2 1/4")**

LH: **X8011 (2 1/2")**

LH: **XSX8011 (2 1/2")**
STAINLESS STEEL

Right:

Left:

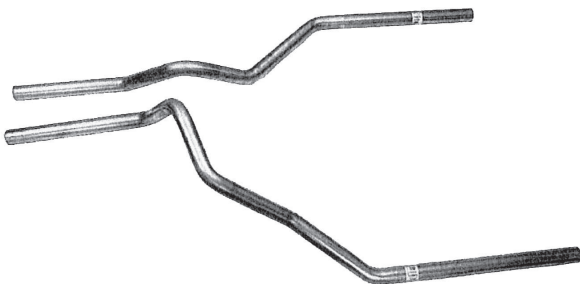

07-11 GM Truck Full Size Pickup

Pipe Also Fits Dodge & Ford Trucks

MAX FIT

RH: **126670 (2 1/2")**

LH: **126671 (2 1/2")**

MANDREL

RH: **X6024 (2 1/2")**

LH: **X6025 (2 1/2")**

Right:

Left:



14 -16 CHEV/GMC Silverado/Sierra 1500; 6 & 8 Cyl; 4.3L, 5.3L, 6.2L; Dual Conversion, 45 Degree Side Exit

GENERAL MOTORS — BUICK/CHEV/GMC/OLDSMOBILE/PONTIAC

MAX FIT

RH: **126667** (2 1/2")

LH: **127695** (2 1/2")

Right:
Left:

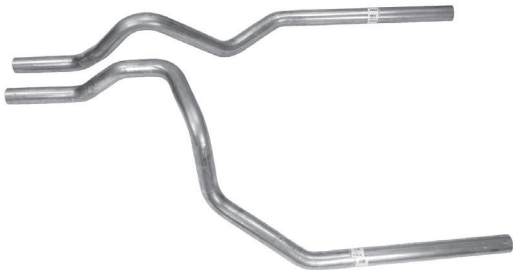

09-13 CHEV/GMC Silverado/Sierra 1500 4.3L, 4.8L, 5.3L, Dual Conversion

MANDREL

RH: **X6020** (2 1/2")

LH: **X7044** (2 1/2")

MAX FIT

RH: **127671** (2 1/2")

LH: **127670** (2 1/2")

Right:

Left:

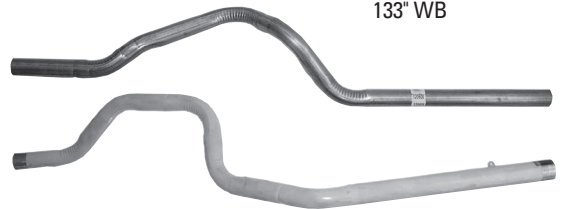

01-06 CHEV/GMC 1500, 2500, 3500HD 6.0L, 8.1L

99-08 CHEV/GMC Truck C, K10, 20, 1500, 2500 (99 New Body Style); 6 & 8 Cyl; 4.3L, 4.8L, 5.3L; 1/2 & 3/4 Ton; 119" WB; 133", 143" WB, 143.5" WB; Dual Conversion

MANDREL

RH: **X6014** (2 1/2")
119" & 143.5" WB

RH: **X7028** (2 1/2")
133" WB

LH: **X6013** (2 1/2")
119" & 143.5" WB

LH: **X7027** (2 1/2")
133" WB

MAX FIT

RH: **127669** (2 1/4")

LH: **127668** (2 1/4")

Right:

Left:



99-08 CHEV/GMC Truck C, K1500, 2500 (99 New Body Style); 6 & 8 Cyl; 4.3L, 4.8L, 5.3L; 1/2 & 3/4 Ton; 119", 133", 143.5" WB; Dual Conversion

MAX FIT

126584 (3")



88-99 CHEV/GMC Truck, Full Size, Light Duty Trucks (99 Pickups w/ Old Body Style); 8 Cyl; 5.7L Eng; (Exclude 88-90 Suburban)

MANDREL

X6007 (3")

XSX6007 (3")
Stainless Steel



01-06 CHEV/GMC C, K1500, 2500, 3500HD; 6.0L, 8.1L

88-99 CHEV/GMC Truck, Full Size, Light Duty Trucks (99 Pickups w/ Old Body Style); 8 Cyl; 5.7L Eng; (Exclude 88-90 Suburban)

PROFESSIONAL INSTALLER PIPES

Sorted by Manufacturer, then Model,
then from Newest to Oldest Application

MAX FIT[®]

with Mandrel Options

GENERAL MOTORS — BUICK/CHEV/GMC/OLDSMOBILE/PONTIAC

MAX FIT

RH: **126102** (2 1/4")
RH: **126104** (2 1/2")

LH: **126103** (2 1/4")
LH: **126105** (2 1/2")



87-02 CHEV./GMC C, K Series; Dual Conversion
Pipe Also Fits Dodge & Ford Trucks

MANDREL

RH: **X6102** (2 1/4")
RH: **X6104** (2 1/2")

LH: **X6103** (2 1/4")
LH: **X6105** (2 1/2")

MAX FIT

RH: **127665** (2 1/2")
LH: **127664** (2 1/2")

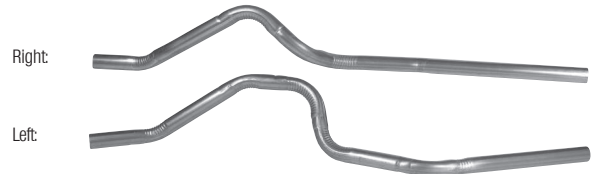

96-99 CHEV/GMC Truck C, K1500, 2500 (Under 8600 lbs. GVW), (99 w/ Old Body Style); 8 Cyl; 350, 5.7L Eng; 117.5", 131.5", 141.5" WB; Dual Conversion

MAX FIT

RH: **127675** (2 1/2")
LH: **127674** (2 1/2")

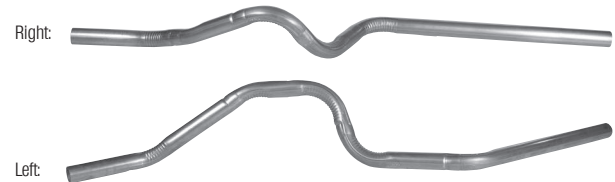

94-95 CHEV/GMC Truck C, K10, 20, 1500, 2500; 6 & 8 Cyl; 262, 4.3L, 305, 5.0L, 350, 5.7L; 117", 131", 141" WB; Dual Conversion

MAX FIT

RH: **127576** (2 1/4")
LH: **127577** (2 1/4")



88-95 CHEV/GMC C, K-Series Truck; Dual Conversion

MAX FIT

OUTER: **125566** (2 1/4")
INNER: **125565** (2 1/4")

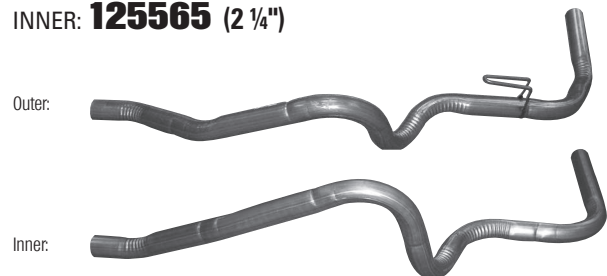

88-95 CHEV/GMC Truck C, K Series; 6 & 8 Cyl.

GENERAL MOTORS — BUICK/CHEV/GMC/OLDSMOBILE/PONTIAC

MAX FIT

RH: **127602** (2 ¼")
RH: **127604** (2 ½")

LH: **127601** (2 ¼")
LH: **127603** (2 ½")



88-93 CHEV/GMC Truck C, K10, 20, 1500, 2500; 8 Cyl;
350, 5.7L; 117", 131", 141" WB (93 w/ OE Converter
Clamped to Front Pipe); Dual Conversion

MAX FIT

RH: **126301** (2 ¼")
RH: **126303** (2 ½")

LH: **126302** (2 ¼")
LH: **126304** (2 ½")



73-87 CHEV/GMC Full Size Light Duty, Pickup;
Dual Conversion

Pipes Also Fit Ford Trucks

MANDREL

RH: **X6301** (3")

LH: **X6302** (3")

MAX FIT

RH: **126625** (2 ¼")

LH: **126624** (2 ¼")



83-01 CHEV/GMC S10/S15; 4 Cyl; 134-4, 2.2L, 151A, 2.5L;
2 WD; 108.3", 117.9", 122.9" WB; Dual Conversion
88-01 CHEV/GMC S10/S15; 6 Cyl; 173R, 2.8L, 262W, X, Z,
4.3L; 2 WD; 108.3", 117.9", 122.9" WB; Dual Conversion
88-94 CHEV/GMC T10/T15; 6 Cyl; 173R, 2.8L, 262W, Z, 4.3L;
4 WD; 108.3", 117.9", 122.9" WB; Dual Conversion

MANDREL

X6008 (3")



88-90 CHEV/GMC Suburban, Light-Duty Trucks 8 Cyl, 5.7L

PROFESSIONAL INSTALLER PIPES

Sorted by Manufacturer, then Model,
then from Newest to Oldest Application

MAX FIT[®]

with Mandrel Options

MAZDA

MAX FIT

RH: **126615** (2")

LH: **127614** (2")



93-00 MAZDA B Series; 4 & 6 Cyl; 2.3L, 2.5L, 3.0L, 4.0L;
All WB; Dual Conversion

Pipes Also Fit Ford Trucks

MITSUBISHI

MAX FIT

RH: **126656** (2 1/2")

LH: **126657** (2 1/2")



06-08 MITSUBISHI Raider, 6 & 8 Cyl; 3.7L, 4.7L Eng., 131"
WB (Extended Cab and Crew Cab); Dual Conversion

NISSAN

MAX FIT

RH: **127684** (2 1/2")

LH: **127783** (2 1/2")



07-15 NISSAN Titan, 5.6L

MANDREL

RH: **X7037** (2 1/2")

LH: **X7046** (2 1/2")

MAX FIT

RH: **127684** (2 1/2")

LH: **127683** (2 1/2")

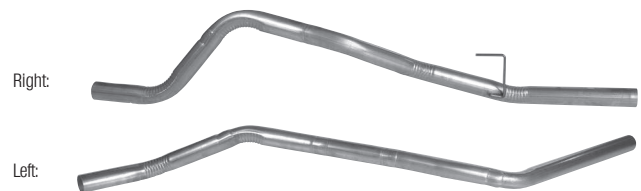

04-06 NISSAN Titan 8 Cyl; 5.6L (King Cab & Crew Cab),
(XE, SE, LE) (Exc. CA); Dual Conversion

TOYOTA

MAX FIT

RH: **128501** (2 1/4")

LH: **128502** (2 1/4")

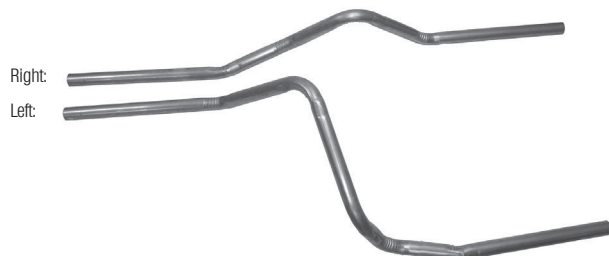

07-14 TOYOTA Tundra; 5.7L

MANDREL

RH: **X8021** (2 1/4")

LH: **X8022** (2 1/4")

MAX FIT

RH: **126650** (2 1/2")

LH: **126651** (2 1/2")



00-06 TOYOTA Tundra; 6 & 8 Cyl; 3.4L, 4.7L Eng (Exc. CA);
Dual Conversion

BENT PIPES

NUMERICAL LISTING

P/N	YEAR	VEHICLE APPLICATION / PART DESCRIPTION	O.A.Length	PART TYPE
121681	95-00	CHRY Cirrus, Sebring 2.4L & 2.5L	8.50"	Exhaust
	95-00	DODGE Stratus 2.0L, 2.4L, & 2.5L		
	98-00	PLYM Breeze 2.0L & 2.4L		
121683	96-00	CHRY/DODGE/PLYM Town & Country, Caravan, Voyager 3.3L & 3.8L	6"	Exhaust
	00-05	DODGE Neon 2.0L		
121685	87-95	FORD Truck E-Series	9.50"	Exhaust
	87-99	FORD Truck F-Series		
121686	96-98	BUICK Skylark 2.4L	4.25"	Exhaust
	96-98	CHEV Cavalier; 97-98 Malibu 2.4L		
	96-98	OLDS Achieva 2.4L		
	96-98	PONT Grand Am, Sunfire 2.4L		
121688	98-03	CHEV/GMC Truck S10, S15 Pickup 2.2L	4.50"	Exhaust
121689	87-92	VW Jetta & Golf 1.8L (w/ 6 Bolt Flange)	3.75"	Exhaust
121690	00-07	FORD Taurus 3.0L	5.44"	Exhaust
	96-98	MERC Sable 3.0L		
121691	05-07	CHEV Cobalt 2.2L	4"	Exhaust
	06-07	CHEV Cobalt 2.4L		
	06-07	CHEV HHR 2.2L & 2.4L		
	05-07	SATURN Ion 2.2L		
	06-07	SATURN Ion 2.4L		
	07	PONTIAC G5 2.2L & 2.4L		
122618	99-02	CHEV Cavalier 2.4L	23.50"	Exhaust
	99-00	CHEV Malibu 2.4L		
	99-01	OLDS Alero 2.4L		
	99-01	PONT Grand Am 2.4L		
	99-02	PONT Sunfire 2.4L		
122621	97-04	BUICK Regal 3.8L	19.50"	Exhaust
	00-05	CHEV Impala, Monte Carlo 3.8L		
	98-99	OLDS Intrigue 3.8L		
	97-03	PONT Grand Prix 3.8L		
122622	2001	CHEV/OLDS/PONT Truck Venture, Silhouette, Montana 3.4L	23.50"	Exhaust
122624	97-04	BUICK Century 3.1L	20.50"	Exhaust
	00-04	CHEV Impala, Monte Carlo 3.4L		
	97-04	PONT Grand Prix 3.1L		
123530	97-00	CHEV Truck Venture 3.4L	26.50"	Exhaust
	97-00	OLDS Truck Silhouette 3.4L		
	99-00	PONT Truck Montana 3.4L		
	97-98	PONT Truck Trans Sport 3.4L		
123532	98-03	CHEV Malibu 3.1L	25"	Exhaust
	99-04	OLDS Alero 3.4L		
	98-99	OLDS Cutlass 3.1L		
	99-04	PONT Grand Am 3.4L		
125564	83-92	FORD Truck Ranger; 4 & 6 Cyl.	59.25"	Tail
125565	88-95	CHEV/GMC Truck C, K Series; 6 & 8 Cyl; Dual Exhaust (Inner Pipe)	58.50"	Tail
125566	88-95	CHEV/GMC Truck C, K Series; 6 & 8 Cyl; Dual Exhaust (Outer Pipe)	60.25"	Tail
125568	83-86	FORD Truck F Series; 6 & 8 Cyl.	55.88"	Tail
	87-97	FORD Truck F350; 6 Cyl.		
125636	84-04	FORD Mustang, GT, LX; Dual Exhaust (Right)	50"	Tail
125637	84-04	FORD Mustang, GT, LX; Dual Exhaust (Left)	50.25"	Tail
126102	87-04	DODGE Truck 1500/2500; Dual Conversion (Right); 2¼" Tailpipe	91.50"	Tail
	87-02	FORD Truck F-Series; Dual Conversion (Right); 2¼" Tailpipe		
	87-02	CHEV/GMC Truck C/K Series; Dual Conversion (Right); 2¼" Tailpipe		

BENT PIPES

NUMERICAL LISTING

MAX FIT[®]
with Mandrel Options

P/N	YEAR	VEHICLE APPLICATION / PART DESCRIPTION	O.A.Length	PART TYPE
126103	87-04	DODGE Truck 1500/2500; Dual Conversion (Left); 2¼" Tailpipe	101"	Tail
	87-02	FORD Truck F-Series; Dual Conversion (Left); 2¼" Tailpipe		
	87-02	CHEV/GMC Truck C/K Series; Dual Conversion (Left); 2¼" Tailpipe		
126104	87-04	DODGE Truck 1500/2500; Dual Conversion (Right); 2½" Tailpipe	91.50"	Tail
	87-02	FORD Truck F-Series; Dual Conversion (Right); 2½" Tailpipe		
	87-02	CHEV/GMC Truck C/K Series; Dual Conversion (Right); 2½" Tailpipe		
126105	87-04	DODGE Truck 1500/2500; Dual Conversion (Left); 2½" Tailpipe	101"	Tail
	87-02	FORD Truck F-Series; Dual Conversion (Left); 2½" Tailpipe		
	87-02	CHEV/GMC Truck C/K Series; Dual Conversion (Left); 2½" Tailpipe		
126301	73-87	CHEV/GMC Truck	67.12"	Tail
	61-86	FORD Truck, Right Side 2 1/4" Tailpipe, Dual Conversion & Single Pipe Side Exit		
126302	73-87	CHEV/GMC Truck	66.75"	Tail
	61-86	FORD Truck, Left Side 2 1/4" Tailpipe, Dual Conversion		
126303	73-87	CHEV/GMC Truck	67.50"	Tail
	61-86	FORD Truck, Right Side 2 1/2" Tailpipe, Dual Conversion & Single Pipe Side Exit		
126304	73-87	CHEV/GMC Truck	67"	Tail
	61-86	FORD Truck, Left Side 2 1/2" Tailpipe, Dual Conversion		
126508	77-90	GM Full Size; Single & Dual Exhaust (Left)	63"	Tail
	64-72	GM Mid Size; Single & Dual Exhaust (Left)		
126543	86-87	GM Century, 6000 Sedan, Cutlass Ciera; 4 Cyl.	66.50"	Exhaust
	84-86	BUICK Century; 6 Cyl.		
	86-87	CHEV Celebrity; 4 Cyl.		
	84-86	CHEV Celebrity Eurosport; 6 Cyl.		
	84-86	OLDS Cutlass Ciera; 6 Cyl.		
	83-86	PONT 6000, 6000 STE Sedan; 6 Cyl., 2" OD Inlet & Outlet		
126546	88-90	GM Century, 6000 Sedan; 4 Cyl.	66.75"	Exhaust
	85-90	GM Century, Cutlass Ciera; 6 Cyl.		
	88-89	CHEV Celebrity Sedan; 4 Cyl.		
	86-89	CHEV Celebrity Eurosport; 6 Cyl.		
	88-90	OLDS Cutlass Ciera Sedan; 4 Cyl.		
	86-90	PONT 6000 S/E, STE; 6 Cyl., 2¼" OD Inlet & Outlet		
126554	77-85	BUICK Full Size	64.75"	Tail
	77-90	CAD Full Size		
	77-88	CHEV Full Size		
	77-85	OLDS Full Size		
	77-86	PONT Full Size		
126555	83-88	FORD Crown Victoria Sedan; Single & Dual Exhaust (Right)	61.50"	Tail
	80-82	FORD LTD Sedan; Single & Dual Exhaust (Right)		
	82-88	LINC Town Car; Single & Dual Exhaust (Right)		
	80-83	LINC Continental, Mark VI; Single & Dual Exhaust (Right)		
	83-88	MERC Grand Marquis Sedan; Single & Dual Exhaust (Right)		
	80-82	MERC Marquis Sedan; Single & Dual Exhaust (Right)		
126558	86-87	BUICK Century; 4 Cyl.	67"	Exhaust
	86-87	CHEV Celebrity; 4 Cyl.		
	86-87	OLDS Ciera; 4 Cyl.		
	86-87	PONT 6000; 4 Cyl., 2" OD Inlet & Outlet		
126563	77-90	GM Full Size; Single & Dual Exhaust (Right)	64.50"	Tail
	64-72	GM Mid Size; Single & Dual Exhaust (Right)		
126582	83-88	FORD Crown Victoria Sedan; Dual Exhaust (Left)	60.25"	Tail
	80-82	FORD LTD Sedan; Dual Exhaust (Left)		
	82-88	LINC Town Car; Dual Exhaust (Left)		
	80-83	LINC Continental, Mark VI; Dual Exhaust (Left)		
	83-88	MERC Grand Marquis Sedan; Dual Exhaust (Left)		
	80-82	MERC Marquis Sedan; Dual Exhaust (Left)		

BENT PIPES

NUMERICAL LISTING

P/N	YEAR	VEHICLE APPLICATION / PART DESCRIPTION	O.A.Length	PART TYPE
126584	88-99	CHEV/GMC Truck Full Size, Light Duty Trucks (99 Pickups w/ Old Body Style), 8 Cyl; 5.7L Eng; (Exc. 88-90 Suburban); Side Exit; 3" Tailpipe	61"	Tail
126615	93-00	FORD/MAZDA Truck Ranger/B Series; 4 & 6 Cyl; 2.3L, 2.5L, 3.0L, 4.0L; All WB; Dual Conversion (Right); 2" Tailpipe	70.63"	Tail
126624	83-01	CHEV/GMC Truck S10/15; 4 Cyl; 134-4, 2.2L, 151A, 2.5L; 2 WD; 108.3", 117.9", 122.9" WB; Dual Conversion (Left); 2 1/4" Tailpipe	65"	Tail
	88-01	CHEV/GMC Truck S10/15; 6 Cyl; 173R, 2.8L, 262W, X, Z, 4.3L; 2 WD; 108.3", 117.9", 122.9" WB; Dual Conversion (Left); 2 1/4" Tailpipe		
	88-94	CHEV/GMC Truck T10/15; 6 Cyl; 173R, 2.8L, 262W, Z, 4.3L; 4 WD; 108.3", 117.9", 122.9" WB; Dual Conversion (Left); 2 1/4" Tailpipe		
126625	83-01	CHEV/GMC Truck S10/15; 4 Cyl; 134-4, 2.2L, 151A, 2.5L; 2 WD; 108.3", 117.9", 122.9" WB; Dual Conversion (Right); 2 1/4" Tailpipe	64.75"	Tail
	88-01	CHEV/GMC Truck S10/15; 6 Cyl; 173R, 2.8L, 262W, X, Z, 4.3L; 2 WD; 108.3", 117.9", 122.9" WB; Dual Conversion (Right); 2 1/4" Tailpipe		
	88-94	CHEV/GMC Truck T10/15; 6 Cyl; 173R, 2.8L, 262W, Z, 4.3L; 4 WD; 108.3", 117.9", 122.9" WB; Dual Conversion (Right); 2 1/4" Tailpipe		
126640	94-96	BUICK Roadmaster Sedan; Resonator Eliminator; Single & Dual Exhaust (Right)	60.25"	Tail
	94-96	CHEV Caprice Sedan, Impala SS Sedan; Resonator Eliminator; Single & Dual Exhaust (Right)		
126641	94-96	BUICK Roadmaster Sedan; Resonator Eliminator; Dual Exhaust (Left)	61.25"	Tail
	94-96	CHEV Caprice Sedan, Impala SS Sedan; Resonator Eliminator; Dual Exhaust (Left)		
126642	82-92	CHEV/PONT Camaro, Firebird; 8 Cyl., 2 1/4" OD Outlet	71.75"	Exhaust
126650	00-06	TOYOTA Truck Tundra; 6 & 8 Cyl; 3.4L, 4.7L Eng (Exc. CA); Dual Conversion (Right); 2 1/2" Tailpipe	78"	Tail
126651	00-06	TOYOTA Truck Tundra; 6 & 8 Cyl; 3.4L, 4.7L Eng (Exc. CA); Dual Conversion (Left); 2 1/2" Tailpipe	78"	Tail
126653	97-01	FORD Truck F150/F250 6 & 8 Cyl., 4.2L, 4.6L, & 5.4L Eng., 120", 139" WBs, 90 Degree Side Exit - Right; Dual Conversion	62.50"	Tail
126656	04-08	DODGE Truck Dakota, All Engs., Club & Quad Cab 131" WB - 2.50" Right; Dual Conversion	66.25"	Tail
	06-07	MINIUBISHI Raider; 6 & 8 Cyl., 3.7L, 4.7L Eng., 131" WB (Extended Cab and Crew Cab); Dual Conversion - 2.50" Right		
126657	04-08	DODGE Truck Dakota, All Engs., Club & Quad Cab 131" WB - 2.50" Left; Dual Conversion	66.50"	Tail
	06-07	MINIUBISHI Raider; 6 & 8 Cyl., 3.7L, 4.7L Eng., 131" WB (Extended Cab and Crew Cab); Dual Conversion - 2.50" Left		
126660	00-03	DODGE Truck Dakota, Quad Cab 112", 131" WB, All Engs., - Right; Dual Conversion	60.75"	Tail
126661	00-03	DODGE Truck Dakota, Quad Cab 112", 131" WB, All Engs., - Left; Dual Conversion	62"	Tail
126663	94-96	BUICK/CHEV Roadmaster, Caprice, Impala SS, 2.25" Dual Exhaust - Left without the last bend	61"	Tail
126664	94-96	BUICK/CHEV Roadmaster, Caprice, Impala SS, 2.25" Dual Exhaust - Right without the last 2 bends	61"	Tail
126665	94-96	BUICK/CHEV Roadmaster, Caprice, Impala SS, 2.50" Dual Exhaust - Left without the last bend	61"	Tail
126666	94-96	BUICK/CHEV Roadmaster, Caprice, Impala SS, 2.50" Dual Exhaust - Right without the last 2 bends	61"	Tail
126667	09-13	CHEV/GMC Silverado/Sierra 1500; 4.3L, 4.8L & 5.3L Engines, Dual Conversion, Right Side 2 1/2" Tailpipe	70"	Tail
126668	14-16	CHEV/GMC Silverado/Sierra 1500 4.3L, 5.3L & 6.2L Engines, Dual Conversions; 2-1/2" Rear Exit Tailpipes - Left	77"	Tail
126669	14-16	CHEV/GMC Silverado/Sierra 1500 4.3L, 5.3L & 6.2L Engines, Dual Conversions; 2-1/2" Rear Exit Tailpipes - Right	73.38"	Tail
126670	14-16	CHEV/GMC Silverado/Sierra 1500 4.3L, 5.3L & 6.2L Engines, Dual Conversions; 2-1/2" 45 Degree Side Exit Tailpipes - Right	48.75"	Tail
126671	14-16	CHEV/GMC Silverado/Sierra 1500 4.3L, 5.3L & 6.2L Engines, Dual Conversions; 2-1/2" 45 Degree Side Exit Tailpipes - Left	57.25"	Tail
126672	04-14	Ford F-150 1500 3.5L Turbo, 4.6L, 5.0L & 5.4L Engines, Dual Conversions; 2-1/4" 45 Degree Side Exit Tailpipes - Right	64.25"	Tail
126687	83-88	CHEV Monte Carlo SS 5.0L, VIN 7 & G; 2.25" OD - Dual Exhaust - Left	61"	Tail

BENT PIPES

NUMERICAL LISTING

MAX FIT
with Mandrel Options

P/N	YEAR	VEHICLE APPLICATION / PART DESCRIPTION	O.A.Length	PART TYPE
126688	83-88	CHEV Monte Carlo SS 5.0L, VIN 7 & G; 2.25" OD - Dual Exhaust - Right	61"	Tail
127553	78-87 78-83 78-87 78-87	BUICK Century, Regal CHEV Chevelle, Malibu, Monte Carlo OLDS Cutlass, Vista Cruiser PONT Bonneville, Grand Am, Grand Prix, LeMans, Flare Inlet, 2" OD Outlet	80.88"	Exhaust
127576	88-95	CHEV/GMC Truck; Dual Conversion (Right); 2¼" Tailpipe	78.50"	Tail
127577	88-95	CHEV/GMC Truck; Dual Conversion (Left); 2¼" Tailpipe	80.50"	Tail
127580	87-96	FORD Truck F150/250 (Under 8500 lbs.GVW); 6 & 8 Cyl; 4.9L, 5.0L, 5.8L; 116", 133", 139" WB; Dual Conversion (Right); 2¼" Tailpipe	81.50"	Tail
127581	87-96	FORD Truck F150/250 (Under 8500 lbs.GVW); 6 & 8 Cyl; 4.9L, 5.0L, 5.8L; 116", 133", 139" WB; Dual Conversion (Left); 2¼" Tailpipe	83"	Tail
127595	87-99	DODGE Truck Dakota; 6 & 8 Cyl; 3.9L, 4.7L, 5.9L; All WB (00-01 112", 131" Club Cab & Quad Cab WB); Dual Conversion (Left); 2½" Tailpipe	79.50"	Tail
127596	87-99	DODGE Truck Dakota; 6 & 8 Cyl; 3.9L, 4.7L, 5.9L; All WB (00-01 112", 131" Club Cab & Quad Cab WB); Dual Conversion (Right); 2½" Tailpipe	74.50"	Tail
127601	88-93	CHEV/GMC Truck C, K10, 20, 1500, 2500; 8 Cyl; 350, 5.7L; 117", 131", 141" WB (93 w/ OE Conv. clamped to front pipe); Dual Conversion (Left); 2¼" Tailpipe	75.75"	Tail
127602	88-93	CHEV/GMC Truck C, K10, 20, 1500, 2500; 8 Cyl; 350, 5.7L; 117", 131", 141" WB (93 w/ OE Conv. clamped to front pipe) Dual Conversion (Right); 2¼" Tailpipe	73.75"	Tail
127603	88-93	CHEV/GMC Truck C, K10, 20, 1500, 2500; 8 Cyl; 350, 5.7L; 117", 131", 141" WB (93 w/ OE Conv. clamped to front pipe) Dual Conversion (Left); 2¼" Tailpipe	75.75"	Tail
127604	88-93	CHEV/GMC Truck C, K10, 20, 1500, 2500; 8 Cyl; 350, 5.7L; 117", 131", 141" WB (93 w/ OE Conv. clamped to front pipe) Dual Conversion (Right); 2¼" Tailpipe	73.75"	Tail
127614	93-00	FORD/MAZDA Truck Ranger/B Series; 4 & 6 Cyl; 2.3L, 2.5L, 3.0L, 4.0L; All WB; Dual Conversion (Left); 2" Tailpipe	74.88"	Tail
127632	97-01	FORD Truck F150/F250 (Under 8800 lbs. GVW), 6 & 8 Cyl; 4.2L, 4.6L, 5.4L; 120", 139" WB; Dual Conversion (Left); 2½" Tailpipe	79.50"	Tail
127633	97-01	FORD Truck F150/F250 (Under 8800 lbs. GVW), 6 & 8 Cyl; 4.2L, 4.6L, 5.4L; 120", 139" WB; Dual Conversion (Right); 2½" Tailpipe	74.25"	Tail
127656	97-01	FORD Truck F150/F250 (Under 8800 lbs. GVW); 6 & 8 Cyl; 4.2L, 4.6L, 5.4L; 120", 139" WB; Dual Conversion (Left); 2¼" Tailpipe	79.50"	Tail
127657	97-01	FORD Truck F150/F250 (Under 8800 lbs. GVW); 6 & 8 Cyl; 4.2L, 4.6L, 5.4L; 120", 139" WB; Dual Conversion (Right); 2¼" Tailpipe	74.25"	Tail
127664	96-99	CHEV/GMC Truck C/K 1500/2500 (Under 8600 lbs. GVW), (99 w/ Old Body Style); 8 Cyl; 350 5.7L Eng; 117.5", 131.5", 141.5" WB; Dual Conversion (Left); 2½" Tailpipe	81"	Tail
127665	96-99	CHEV/GMC Truck C/K 1500/2500 (Under 8600 lbs. GVW), (99 w/ Old Body Style); 8 Cyl; 350 5.7L Eng; 117.5", 131.5", 141.5" WB; Dual Conversion (Right); 2½" Tailpipe	81"	Tail
127666	02-03	FORD Truck F150/F250 (Under 8800 lbs. GVW); 6 & 8 Cyl; 4.2L, 4.6L, 5.4L; 120", 139" WB; Dual Conversion (Right); 2¼" Tailpipe	73"	Tail
127668	99-08	CHEV/GMC C/K 1500/2500 (99 New Body Style); 6 & 8 Cyl; 4.3L, 4.8L, 5.3L; ½ & ¾ Ton; 119", 133", 143.5" WB; Dual Conversion (Left); 2¼" Tailpipe	81"	Tail
127669	99-08	CHEV/GMC C/K 1500/2500 (99 New Body Style); 6 & 8 Cyl; 4.3L, 4.8L, 5.3L; ½ & ¾ Ton; 119", 133", 143.5" WB; Dual Conversion (Right); 2¼" Tailpipe	77"	Tail
127670	99-05	CHEV/GMC Truck C, K10, 20, 1500, 2500 (99 New Body Style); 6 & 8 Cyl; 4.3L, 4.8L, 5.3L; 119" WB (Std. Cab/Short Bed); 133"; 143" WB (Ext. Cab/Short Bed); Dual Conversion (Left); 2½" Tailpipe	69.50"	Tail
127671	99-05	CHEV/GMC Truck C, K10, 20, 1500, 2500 (99 New Body Style); 6 & 8 Cyl; 4.3L, 4.8L, 5.3L; 119" WB (Std. Cab/Short Bed); 133"; 143" WB (Ext. Cab/Short Bed); Dual Conversion (Right); 2½" Tailpipe	75.50"	Tail
127674	94-95	CHEV/GMC C, K10, 20, 1500, 2500; 6 & 8 Cyl; 262, 4.3L, 305, 5.0L, 350, 5.7L; 117", 131", 141" WB; Dual Conversion (Left); 2½" Tailpipe	84"	Tail
127675	94-95	CHEV/GMC C, K10, 20, 1500, 2500; 6 & 8 Cyl; 262, 4.3L, 305, 5.0L, 350, 5.7L; 117", 131", 141" WB; Dual Conversion (Right); 2½" Tailpipe	81"	Tail
127676	02-05	DODGE Truck Ram 1500/2500 (Under 8800 lbs. GVW); 6 & 8 Cyl; 3.7L, 4.7L, 03-05 5.7L Hemi Engine, 02-03 5.9L; 140" WB; (Regular Cab/Short Bed & Quad Cab/Short Bed) Dual Conversion (Right); 2¼" Tailpipe	82"	Tail
127681	02-05	DODGE Truck Ram 1500/2500 (Under 8800 lbs. GVW); 6 & 8 Cyl; 3.7L, 4.7L; 120" WB; Dual Conversion (Left); 2¼" Tailpipe	79"	Tail

PIPES

BENT PIPES

NUMERICAL LISTING

P/N	YEAR	VEHICLE APPLICATION / PART DESCRIPTION	O.A.Length	PART TYPE
127682	02-05	DODGE Truck Ram 1500/2500 (Under 8800 lbs. GVW); 6 & 8 Cyl; 3.7L, 4.7L;120" WB; Dual Conversion (Right); 2 1/4" Tailpipe	81"	Tail
127683	04-06	NISSAN Titan; 8 Cyl; 5.6L (King Cab & Crew Cab), (XE, SE, LE) Exc. CA; Dual Conversion (Left); 2 1/2" Tailpipe	79"	Tail
127684	07-15	NISSAN Titan; 8 Cyl; 5.6L (King Cab & Crew Cab), (XE, SE, LE) Exc. CA; Dual Conversion (Right); 2 1/2" Tailpipe	79"	Tail
127685	04-08 06-08	FORD F150 (New Body Style); 8 Cyl; 4.6L, 5.4L; All WBs; Dual Conversion (Left); 2 1/4" Tailpipe LINC Mark LT; 8 Cyl; 5.4L; 139" WB; Dual Conversion (Left); 2 1/4" Tailpipe	83.50"	Tail
127686	04-14 06-08	FORD F150 (New Body Style); 8 Cyl; 3.5L Turbo; 4.6L, 5.0L; 5.4L; All WBs; Dual Conversion (Right); 2 1/4" Tailpipe LINC Mark LT; 8 Cyl; 5.4L; 139" WB; Dual Conversion (Right); 2 1/4" Tailpipe	75.50"	Tail
127687	06-08	DODGE Truck Ram 1500, 3.7L, 4.7L, & 5.7L Eng., 120", 140" WB - Left; Dual Conversion	83"	Tail
127688	06-08	DODGE Truck Ram 1500, 3.7L, 4.7L, & 5.7L Eng., 120", 140" WB - Right; Dual Conversion	81"	Tail
127689	97-01	FORD Truck F150/F250 6 & 8 Cyl., 4.2L, 4.6L, & 5.4L Eng., 120", 139" WB, 90 Degree Side Exit; Dual Conversion- Left	63.75"	Tail
127693	07-08	NISSAN Truck Titan, 8 Cyl., 5.6L Eng., (King Cab & Crew Cab), (XE, SE, LE) Exc. CA; 2.50" Dual Conversion - Left	79"	Tail
127694	2009	DODGE Truck Ram1500, 5.7L Eng., 140.5" WB - Dual Conversion - Right	81.50"	Tail
127695	09-13	CHEV/GMC Silverado/Sierra 1500; 4.3L, 4.8L & 5.3L Engines, Dual Conversion, Left Side 2 1/2" Tailpipe	76"	Tail
127697	04-14	FORD F150, 6 & 8 Cyl., 3.5L Turbo, 4.6L, 5.0L, 5.4L, Dual Conversion, Left Side, 45 Degree Side Exit	74.25"	Tail
127783	07-15	NISSAN Titan, 5.6L Engine, Dual Conversion Tailpipe, Left, 8 Cyl.	79"	Tail
128009	07-08 07-11 07-11	DODGE Ram Full Size (Left); 2 1/4"; Dual Conversion FORD F-Series Full Size (Left); 2 1/4"; Dual Conversion GM Truck Full Size (Left); 2 1/4"; Dual Conversion	89.75"	Tail
128010	07-08 07-11 07-11	DODGE Ram Full Size (Right); 2 1/4"; Dual Conversion FORD F-Series Full Size (Right); 2 1/4"; Dual Conversion GM Truck Full Size (Right); 2 1/4"; Dual Conversion	83.50"	Tail
128011	07-08 07-11 07-11	DODGE Ram Full Size (Left); 2 1/2"; Dual Conversion FORD F-Series Full Size (Left); 2 1/2"; Dual Conversion GM Truck Full Size (Left); 2 1/2"; Dual Conversion	89.75"	Tail
128012	07-08 07-11 07-11	DODGE Ram Full Size (Right); 2 1/2"; Dual Conversion FORD F-Series Full Size (Right); 2 1/2"; Dual Conversion GM Truck Full Size (Right); 2 1/2"; Dual Conversion	83.50"	Tail
128501	07-14	TOYOTA Tundra, 5.7L Engine, Dual Conversion, 2 1/4", Right, 8 Cyl.	88.88"	Tail
128502	07-14	TOYOTA Tundra, 5.7L Engine, Dual Conversion, 2 1/4", Left, 8 Cyl.	91.50"	Tail
128593	94-01	DODGE Truck Ram 1500/2500 (Under 8800 lbs. GVW); 6 & 8 Cyl; 3.9L, 5.2L, 5.9L; 119", 135", 139" WB; Dual Conversion (Left); 2 1/2" Tailpipe	89"	Tail
128594	94-01	DODGE Truck Ram 1500/2500 (Under 8800 lbs. GVW); 6 & 8 Cyl; 3.9L, 5.2L, 5.9L; 119", 135", 139" WB; Dual Conversion (Right); 2 1/2" Tailpipe	91"	Tail
128662	94-01	DODGE Truck Ram 1500/2500 (Under 8800 lbs. GVW); 6 & 8 Cyl; 3.9L, 5.2L, 5.9L; 119", 135", 139" WB; Dual Conversion (Left); 2 1/4" Tailpipe	93.50"	Tail
128663	94-01	DODGE Truck Ram 1500/2500 (Under 8800 lbs. GVW); 6 & 8 Cyl; 3.9L, 5.2L, 5.9L; 119", 135", 139" WB; Dual Conversion (Right); 2 1/4" Tailpipe	91"	Tail
128667	02-03	FORD Truck F150/250 (Under 8800 lbs. GVW); 6 & 8 Cyl; 4.2L, 4.6L, 5.4L; 120", 139" WB; Dual Conversion (Left); 2 1/4" Tailpipe	80"	Tail
128677	02-05	DODGE Truck Ram 1500/2500 (Under 8800 lbs. GVW); 6 & 8 Cyl; 3.7L, 4.7L Eng, 03-05 5.7L Hemi Engine, 02-03 5.9L; 140" WB; (Regular Cab/Short Bed & Quad Cab/Short Bed) Dual Conversion (Left); 2 1/4" Tailpipe	87"	Tail
128678	2009	DODGE Truck Ram1500, 5.7L Eng., 140.5" WB - Dual Conversion - Left	81.50"	Tail

ACCESSORIES

ACCESSORIES

CLAMPS

STANDARD DUTY 5/16" U-BOLT



P/N	SIZE	BOX QTY
U118	1 1/8"	1
U114	1 1/4"	1
U112	1 1/2"	1
U158	1 5/8"	1
U134	1 3/4"	1
U178	1 7/8"	1
U200	2"	1
U218	2 1/8"	1
U214	2 1/4"	1
U212	2 1/2"	1

STANDARD DUTY 5/16" U-BOLT W/ FLANGE NUT



P/N	SIZE	BOX QTY
339976	1 1/2"	50
339977	1 5/8"	50
339978	1 3/4"	50
339979	1 7/8"	50
339980	2"	50
339982	2 1/4"	50
339983	2 1/2"	50

SLOTTED HD 3/8" U-BOLT W/ FLANGE NUT



P/N	SIZE	BOX QTY
339893	1 1/2"	100
339892	1 3/4"	100
339891	1 7/8"	100
339890	2"	100
339889	2 1/4"	100
339888	2 1/2"	100

DGM STYLE 3/8" U-BOLT W/ FLANGE NUT



P/N	SIZE	BOX QTY	P/N	SIZE	BOX QTY
M112	1 1/2"	1	339862	1 1/2"	100
M158	1 5/8"	1			
M134	1 3/4"	1	339880	1 3/4"	100
M178	1 7/8"	1	339879	1 7/8"	100
M200	2"	1	339878	2"	100
M218	2 1/8"	1	339877	2 1/8"	100
M214	2 1/4"	1	339876	2 1/4"	100
M212	2 1/2"	1	339875	2 1/2"	100
M300	3"	1	9972	3"	50

HEAVY DUTY 3/8" U-BOLT TRUCK CLAMPS



P/N	P/N ZINC	SIZE	BOX QTY
H234P	—	2 3/4"	1
—	H300PZ	3"	1
H312P	H312PZ	3 1/2"	1
H400P	H400PZ	4"	1
H412P	H412PZ	4 1/2"	1
H500P	H500PZ	5"	1

EXTRA HEAVY DUTY CLAMPS 3/8" U-BOLT 11 GAUGE SADDLE

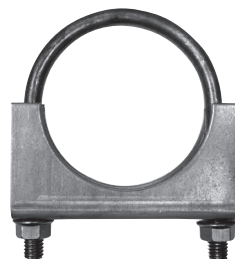

P/N	P/N ZINC	SIZE	BOX QTY	P/N	P/N ZINC	SIZE	BOX QTY
H200	—	2"	1	H300*	H300Z	3"	1
H218	—	2 1/8"	1	H314*	—	3 1/4"	1
H214	—	2 1/4"	1	H312*	—	3 1/2"	1
H238	—	2 3/8"	1	H400*	H400Z	4"	1
H212	MC212ZP	2 1/2"	1	H412*	—	4 1/2"	1
H258*	—	2 5/8"	1	H500*	H500Z	5"	1
H234*	—	2 3/4"	1	H600*	H600Z	6"	1

*Welded Saddle

STAINLESS STEEL 3/8" U-BOLT



P/N	SIZE	BOX QTY
SS112	1 1/2"	1
SS134	1 3/4"	1
SS178	1 7/8"	1
SS200	2"	1
SS214	2 1/4"	1
SS212	2 1/2"	1
SS300	3"	1

CLAMPS

FLAT BAND CLAMPS

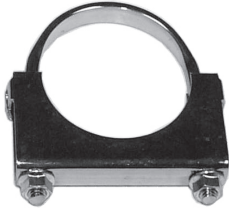

P/N ZINC	P/N CHROME	SIZE	BOX QTY
9501	9490	3"	1
9502	—	3 ½"	1
9503	9492	4"	1
9504	9493	5"	1
9736	—	5 ½"	1
9506	9495	6"	1

HEAVY DUTY GUILLOTINE CLAMPS



P/N	P/N ZINC	P/N CHROME	SIZE	BOX QTY
T234	—	—	2 ¾"	1
T300	T300Z	—	3"	1
T314	—	—	3 ¼"	1
T312	T312Z	—	3 ½"	1
T400	T400Z	—	4"	1
—	T412Z	—	4 ½"	1
T500	T500Z	9487	5"	1
—	T512Z	—	5 ½"	1
T600	T600Z	—	6"	1

AIR TUBE SADDLE CLAMPS



P/N	SIZE	BOX QTY
4904	½"	25
4914	5/8"	25
4907	¾"	25
4925	1"	25

AUDI - VW- BMW MUSTANG SLEEVE CLAMPS



P/N	SIZE	LENGTH	PKG QTY
8640	2 ¼"	5"	1
8641	2"	5"	1
8642	2 ½"	5"	1
8645	2 ½"	3 5/8"	1

PREFORMED CLAMPS W/ GASKET - LAP JOINT



P/N	SIZE	MATERIAL
9700	3"	ALUMINIZED STEEL
9701	3 ½"	ALUMINIZED STEEL
9702	4"	ALUMINIZED STEEL
9703	5"	ALUMINIZED STEEL
9730	3"	BRIGHT 304 SS
9731	3 ½"	BRIGHT 304 SS
9732	4"	BRIGHT 304 SS
9733	5"	BRIGHT 304 SS

PREFORMED CLAMPS - LAP JOINT



HVY DUTY P/N	ALT P/N	SIZE	MATERIAL
9660	—	2"	ALUMINIZED STEEL
9661	—	2 ¼"	ALUMINIZED STEEL
9662	—	2 ½"	ALUMINIZED STEEL
9663	—	2 ¾"	ALUMINIZED STEEL
9604	—	3"	ALUMINIZED STEEL
9605	—	3 ½"	ALUMINIZED STEEL
9606	LA400	4"	ALUMINIZED STEEL
—	LA412	4 ½"	ALUMINIZED STEEL
9607	—	5"	ALUMINIZED STEEL

Hvy Duty P/N	ALT P/N	SIZE	MATERIAL
9664	—	2"	BRIGHT 304 SS
9665	—	2 ¼"	BRIGHT 304 SS
9666	LS212	2 ½"	BRIGHT 304 SS
9667	—	2 ¾"	BRIGHT 304 SS
9668	—	3"	BRIGHT 304 SS
9669	LS312	3 ½"	BRIGHT 304 SS
—	LS334	3 ¾"	BRIGHT 304 SS
9623	LS400	4"	BRIGHT 304 SS
9670	—	4 ½"	BRIGHT 304 SS
9624	LS500	5"	BRIGHT 304 SS
9671	LS600	6"	BRIGHT 304 SS

* SS = Stainless Steel

ACCESSORIES

ACCESSORIES

CLAMPS

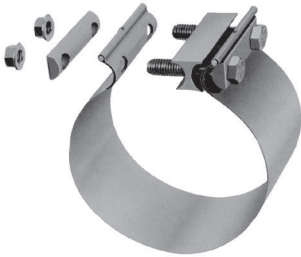

PREFORMED CLAMPS - BUTT JOINT

HVY DUTY P/N	ALT P/N	SIZE	MATERIAL
9676	BA300	3"	ALUMINIZED STEEL
9678		3 1/2"	ALUMINIZED STEEL
9680		4"	ALUMINIZED STEEL
9682	BA500	5"	ALUMINIZED STEEL
9683		6"	ALUMINIZED STEEL

HVY DUTY P/N	ALT P/N	SIZE	MATERIAL
9684		2"	BRIGHT 304 SS
9685		2 1/4"	BRIGHT 304 SS
9686		2 1/2"	BRIGHT 304 SS
9687		2 3/4"	BRIGHT 304 SS
9688	BS300	3"	BRIGHT 304 SS
9690		3 1/2"	BRIGHT 304 SS
9692		4"	BRIGHT 304 SS
9693		4 1/2"	BRIGHT 304 SS
9694	BS500	5"	BRIGHT 304 SS
9695		6"	BRIGHT 304 SS

* SS = Stainless Steel

FLATBAND EXHAUST CLAMPS



HVY DUTY P/N	ALT P/N	SIZE	MATERIAL
AS200		2"	ALUMINIZED STEEL
AS214	FA214	2 1/4"	ALUMINIZED STEEL
AS212	FA212	2 1/2"	ALUMINIZED STEEL
AS234	FA234	2 3/4"	ALUMINIZED STEEL
AS300	FA300	3"	ALUMINIZED STEEL
AS312	FA400	3 1/2"	ALUMINIZED STEEL
AS400		4"	ALUMINIZED STEEL
AS500		5"	ALUMINIZED STEEL

HVY DUTY P/N	ALT P/N	SIZE	MATERIAL
SAS200		2"	BRIGHT 430 SS
SAS214	FS214	2 1/4"	BRIGHT 430 SS
SAS212	FS212	2 1/2"	BRIGHT 430 SS
SAS234	FS234	2 3/4"	BRIGHT 430 SS
SAS300	FS300	3"	BRIGHT 430 SS
SAS312	FS312	3 1/2"	BRIGHT 430 SS
SAS400		4"	BRIGHT 430 SS
SAS500		5"	BRIGHT 430 SS
SAS600		6"	BRIGHT 430 SS

* SS = Stainless Steel



FLATBAND EXHAUST CLAMPS

HVY DUTY P/N	ALT P/N	SIZE	MATERIAL
B200	FB200	2"	BRIGHT 304 SS
B214		2 1/4"	BRIGHT 304 SS
B212	FB212	2 1/2"	BRIGHT 304 SS
B234	FB234	2 3/4"	BRIGHT 304 SS
B300	FB300	3"	BRIGHT 304 SS
B314		3 1/4"	BRIGHT 304 SS
B312	FB312	3 1/2"	BRIGHT 304 SS
B400	FB400	4"	BRIGHT 304 SS
B412		4 1/2"	BRIGHT 304 SS
B500	FB500	5"	BRIGHT 304 SS
B600	FB600	6"	BRIGHT 304 SS
B800		8"	BRIGHT 304 SS
B1000		10"	BRIGHT 304 SS



CHRYSLER V-BAND CLAMP

Fits 2 1/2" Pre-Cat Inlet

P/N	SIZE	MATERIAL
8610	2 1/2"	STAINLESS STEEL

* SS = Stainless Steel

CLAMPS

V-BAND CLAMPS

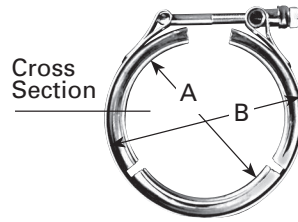

View of Cross Section

Manufacturer	P/N	Tube Dia.	A	B	C	Application
UNIVERSAL						
	9398	3.00	3.26	4.06	0.02	Fits - OEM MUFFLERS.
	9399	4.00	4.25	4.81	0.21	Fits - FLARED CONNECTORS.
	9616	5.00	4.97	5.25	0.26	Fits - FLARED CONNECTORS.
AIRESEARCH						
	9614	4.00	4.17	4.61	0.16	TEO-699
	9616	5.00	4.97	5.25	0.26	T-1899, TH08A64
BLUE BIRD						
	9618	2.75	2.80	3.20	0.26	REPLACES BLUEBIRD #1334226
	9618	2.75	2.80	3.20	0.26	94-98 BLUEBIRD TC2000 SCHOOL BUS W/5.9L
	9651	4.00	4.13	4.69	0.40	REPLACES BLUEBIRD #125046
	9651	4.00	4.13	4.69	0.40	BLUEBIRD ALL AMERICAN W/CAT3116 /TURBO
	9399	4.00	4.25	4.81	0.21	REPLACES BLUEBIRD #0997791
	9399	4.00	4.25	4.81	0.21	1980-90 BLUEBIRD SCHOOL BUS W/8.2LT
CATERPILLAR						
	9622	3.50	3.63	4.19	0.40	3208T
	9396	3.50	3.94	4.50	0.21	3208T
	9651	4.00	4.13	4.69	0.40	3208T
	9652	4.00	4.12	4.81	0.40	3176T
	9653	4.00	4.19	4.75	0.40	3176T
	9615	5.00	5.32	5.88	0.40	3406, 3406B, 3176
CUMMINS						
	9618	2.75	2.80	3.20	0.26	6BT5.9L, 6BTA5.9L
	9612	3.00	3.32	3.88	0.40	V555, V902, V903
	9627	3.50	3.69	4.25	0.40	VT555, VT-555 MANIFOLD
	9396	3.50	3.94	4.50	0.21	VT555, VT-555 MANIFOLD
	9652	4.00	4.12	4.81	0.40	L10
	9653	4.00	4.19	4.75	0.40	L10
	9615	5.00	5.32	5.88	0.40	750, N, 88NT, NTC, VT
DETROIT DIESEL						
	9395	3.00	3.26	3.82	0.21	6V53, 6V71
	9656	3.50	3.76	4.04	0.26	
	9613	3.50	3.77	4.33	0.21	
	9396	3.50	3.94	4.50	0.21	4-53, 8V71, 8V92
	9617	4.00	4.13	4.75	0.16	8.2LT
	9399	4.00	4.25	4.81	0.21	6-71T, 8.2N, 8.2T, 12V71
	9735	4.00	4.97	5.25	0.26	8V-71T, 16V-71, 6V-92T, 8V-92, 8V-92T, 16V-92T
	9616	5.00	4.97	5.25	0.26	8V-71T
	9397	5.00	5.32	5.92	0.28	6V-92, 8V-71T (END AWAY FROM TURBO)
	9615	5.00	5.32	5.88	0.40	SERIES 60, 6-71T

ACCESSORIES



CLAMPS

V-BAND CLAMPS (Cont.)

Manufacturer	P/N	Tube Dia.	A	B	C	Application
FORD						
	9610	3.00	3.25	3.87	0.43	FORD #E5HZ5A231B
	9618	2.75	2.80	3.20	0.26	93-95 B600/700 W/5.9LT
	9618	2.75	2.80	3.20	0.26	REPLACES FORD #F3HZ5A281A
	9656	3.50	3.76	4.04	0.26	FORD #E0HZ5A231B
	9625	3.00	3.05	3.62	0.28	REPLACES FORD #F1HZ5C210A, E9HZ5A231B
	9625	3.00	3.05	3.62	0.28	89-95 MED/TRUCK,BUS W/370, 429 GAS
	9395	3.00	3.26	3.82	0.21	ALL MODELS W/DD 6V53, 6V71
	9395	3.00	3.26	3.82	0.21	ALL MODELS W/CUMMINS V555, V902
	9611	3.00	3.50	4.06	0.24	8.2L NA
	9622	3.50	3.63	4.19	0.40	REPLACES FORD #E2HZ5A231A
	9622	3.50	3.63	4.19	0.40	87-90 B600/700 SCHOOL BUS CF600/800 W/6.6LT
	9622	3.50	3.63	4.19	0.40	REPLACES FORD #E8HZ5A231E
	9627	3.50	3.69	4.25	0.40	87-94 CF600/800, F600/800 W/7.8LT
	9627	3.50	3.69	4.25	0.40	REPLACES FORD #E7HZ5A231C
	9617	4.00	4.13	4.75	0.16	REPLACES FORD #E0HZ5A231C
	9399	4.00	4.25	4.81	0.21	ALL MODELS W/DD 6-71T, 8.2N, 8.2T, 12V71
FREIGHTLINER						
	9601	3.50"	3.38"	3.75"	0.75"	02-06 FREIGHTLINER BUS W/MERCEDES ENG. OE#A04-19184-000
	9609	4.00	4.19	4.75	0.40	FREIGHTLINER BUS W/MERCEDES 6 CYL. ENG.
	9615	5.00	5.32	5.88	0.40	FLD MODELS W/DD SERIES 60, CAT 3406
	9615	5.00	5.32	5.88	0.40	FLD MODELS W/CUMMINS NTC, VT DIESEL
	9615	5.00	5.32	5.88	0.40	REPLACES FREIGHTLINER #0114596000
GM						
	9656	3.50	3.76	4.04	0.26	
	9611	3.00	3.50	4.06	0.24	80-90-GM MED TRUCK/BUS W/8.2L NA
	9611	3.00	3.50	4.06	0.24	REPLACES GM #2069773
	9652	4.00	4.12	4.81	0.40	TOPKICK/KODIAK W/6.6L
	9652	4.00	4.12	4.81	0.40	REPLACES GM #15647159
	9399	4.00	4.25	4.81	0.21	ALL MODELS W/DD6-71T, 8.2N, 8.2T, 12V71
INTERNATIONAL						
	9627	3.50	3.69	4.25	0.40	86-89 SERIES S TRUCK/BUS W/DT360
	9627	3.50	3.69	4.25	0.40	REPLACES INTERNATIONAL #893944R92
	9613	3.50	3.77	4.33	0.21	REPLACES INTERNATIONAL #338614C1
	9613	3.50	3.77	4.33	0.21	88-94 SERIES S TRUCK BUS W/DT466
	9396	3.50	3.94	4.50	0.21	REPLACES INTERNATIONAL #434252R91
	9396	3.50	3.94	4.50	0.21	ALL MODELS W/DD 4-53, 8V71, 8V92, CAT 3208T
	9396	3.50	3.94	4.50	0.21	ALL MODELS W/CUMMINS VT-555
	9737	3.00	3.28	3.84	0.40	T444E 1994-2000 INTERNATIONAL BUS
	9653	4.00	4.19	4.75	0.40	REPLACES INTERNATIONAL #893945R92
	9653	4.00	4.19	4.75	0.40	7.3L, DT-DTA 360, DT-DTA 466
	9735	4.00	4.97	5.25	0.26	9300 SERIES W/DD 8V71, 8V92
	9735	4.00	4.97	5.25	0.26	REPLACES INTERNATIONAL #5132650
	9735	4.00	4.97	5.25	0.26	REPLACES INTERNATIONAL # 780067C91
	9615	5.00	5.32	5.88	0.40	REPLACES INTERNATIONAL #390226C91
	9615	5.00	5.32	5.88	0.40	INTERNATIONAL #1672105C91

ACCESSORIES

CLAMPS

V-BAND CLAMPS (Cont.)

Manufacturer	P/N	Tube Dia.	A	B	C	Application
MACK						
	9396	3.50	3.94	4.50	0.21	ALL MODELS W/DD 4-53, 8V71, 8V92, CAT 3208T
	9396	3.50	3.94	4.50	0.21	ALL MODELS W/CUMMINS VT-555
	9614	4.00	4.17	4.61	0.16	REPLACES MACK #48RU2341
	9614	4.00	4.17	4.61	0.16	DM/MR MODELS
	9399	4.00	4.25	4.81	0.21	ALL MODELS W/DD 6-71T, 8.2N, 8.2T, 12V71
	9619	4.00	4.38	4.94	0.18	REPLACES MACK #11ME29
	9615	5.00	5.32	5.88	0.40	REPLACES MACK #11ME241
PETERBILT						
	9616	5.00	4.97	5.25	0.26	PETERBILT #14-11039
THOMAS						
	9622	3.50	3.63	4.19	0.40	84-90 SAF-T-LINER MODELS W/3208T
	9622	3.50	3.63	4.19	0.40	REPLACES THOMAS #61240207
	9651	4.00	4.13	4.69	0.40	84-89 THOMAS SCHOOL BUS W/ 3208T
	9651	4.00	4.13	4.69	0.40	REPLACES THOMAS #61240208
	9397	5.00	5.32	5.92	5.92	90-93 THOMAS SCHOOL BUS W/6V92
	9397	5.00	5.32	5.92	5.92	REPLACES THOMAS #61240715

CLAMPS

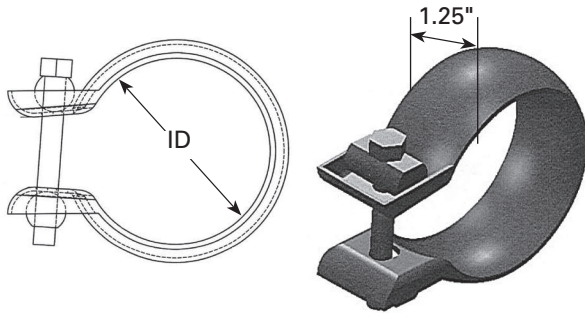

SWIVEL JOINT CLAMPS

P/N	REPLACES
8620	GM 20779889
8625	CHRYSLER 4578916AB
8330	FORD 8R3Z-5A231-B



8901



8678

1995-2006 TOYOTA/SCION 1.5L

P/N	O.E. NUMBER
8901	9046115013
8678	9091706082

ACCESSORIES

HANGERS

MUFFLER SHOP HANGER

SADDLE SWIVELS ON RUBBER STRAP

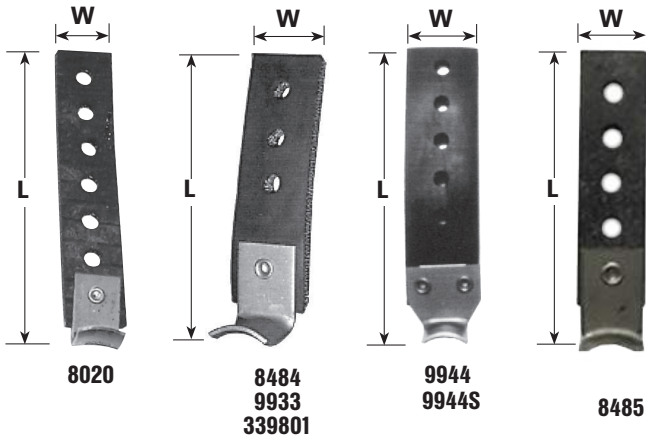

P/N	SIZE	BOX QTY
8484	5 1/2"L x 1 3/8"W x 3/8"D	1
9933	5 1/2"L x 1 3/8"W x 3/8"D	100
339801	5 1/2"L x 1 3/8"W x 9/16"D	100
8485	5 3/4"L x 1 3/8"W x 5/8"D	1
8020	7"L x 1 1/8"W x 5/16"D	1
9944	8"L x 2"W x 1 1/32"D	50
9944S	8"L x 2"W x 1 1/32"D	1

UNIVERSAL HANGER

BULK P/N	BOX QTY	SINGLE PACK P/N	LENGTH	ROD DIA
339816	50	339816S	10"	3/8"
339819	50	339819S	10"	3/8"
339820	25	339820S	10"	1/2"
339821	50		NA	3/8"

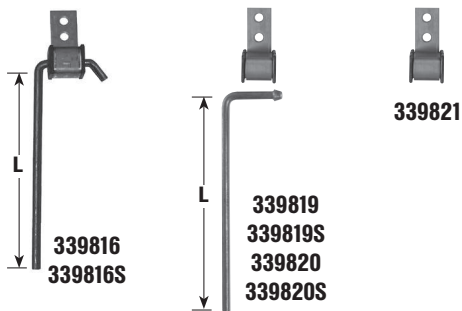

UNIVERSAL HANGER

P/N	BOX QTY
8301	1
8053	1

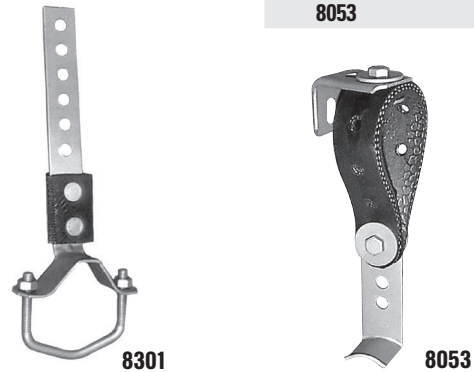

HEAVY DUTY UNIVERSAL TRUCK HANGER



P/N	BOX QTY
8462	1

Fabric has 3 holes for adjusting bracket position.

UNIVERSAL TAILPIPE HANGER KIT

P/N	BOX QTY
8362	2



GM HANGER

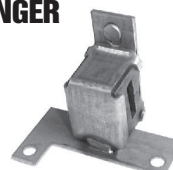

P/N	BOX QTY
8011	1

HANGERS

UNIVERSAL WIRE HANGERS

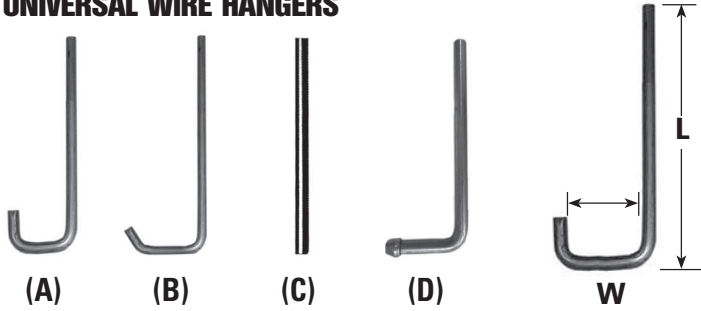

P/N	LENGTH	WIDTH	WIRE ROD	TYPE	BOX QTY
FW2014	14"	—	5/16"	C	25
FW2906	6"	1 1/4"	5/16"	A	25
FW2908	8"	1 1/4"	5/16"	A	25
FW3408	8 1/2"	2"	3/8"	B	25
FW3908	8"	1 1/4"	3/8"	A	25
FW3921	10"	2"	3/8"	A	25
FW3928	8"	2"	3/8"	A	25
FW3951	10"	2"	3/8"	D	25
FW5014	14"	—	1/2"	C	15
FW5908	8"	1 1/2"	1/2"	A	15
FW5951	10"	2"	1/2"	D	15
FW5958	8"	2"	1/2"	D	15

UNIVERSAL WIRE HANGERS

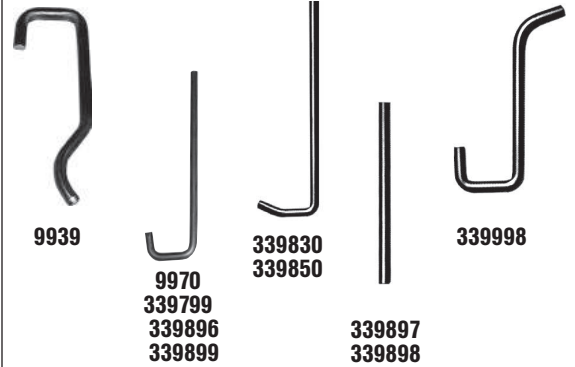

P/N	LENGTH	WIRE ROD	BOX QTY
9939	5 1/2"	3/8"	50
9970	5 1/8"	3/8"	50
339799	7 1/2"	3/8"	25
339830	10"	3/8"	25
339850	10"	1/2"	15
339896	7 1/2"	5/16"	25
339897	14"	3/8"	25
339898	10"	5/16"	25
339899	9"	5/16"	25
339998	6"	5/16"	100

SPECIALTY HANGER



P/N	BOX QTY
339995 (Bulk)	10
8516	1

O-RING/BACKET



P/N	BOX QTY
9959 (Bulk)	50
8166	1

UNIVERSAL BRACKET

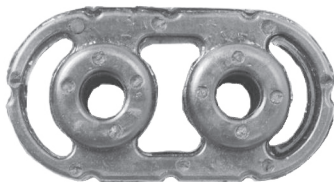

P/N	LENGTH	WIDTH	DEPTH	HOLE DIA.	QTY
8172	2 7/8"	1 1/2"	7/8"	1 1/32"	1

GM UNIVERSAL MIDGET 360° HANGERS

These hangers pivot 90° at two separate points and rotate 360° for maximum flexibility.

OPEN END



9943 - Bulk Part No.
8236 - Single Pack No.

CLOSED END



339860 - Bulk Part No.
339860S - Single Pack No.

ACCESSORIES

360° HANGERS

360° HANGERS

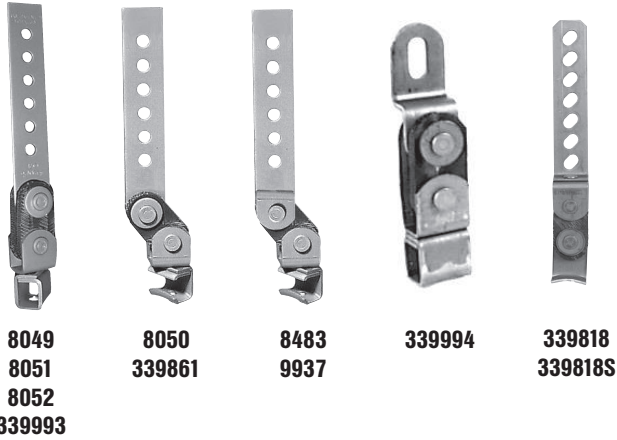

BULK P/N	BOX QTY	SINGLE PACK P/N	TYPE	LENGTH
—	1	8049	Reg. Closed	9 ½"
—	1	8050	Reg. Open	9 ¾"
—	1	8052	Med. Closed	13 ¼"
—	1	8051	Long Closed	17 ¼"
—	1	8483	Reg. Open	9 ½"
9937	50	—	Reg. Open	9 ½"
339818	50	339818S	Reg. Curved	9 ½"
339861	50	—	Reg. Open	9 ¾"
339993	50	—	Reg. Closed	9 ½"
339994	50	339994S	Short Closed	5 ⅝"

BRACKETS

CHRYSLER TAIL PIPE BRACKET



P/N	BOX QTY
9950 (Bulk)	50
8503	1

UNIVERSAL TAIL PIPE BRACKET

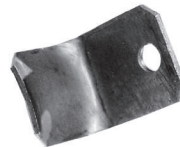

P/N	BOX QTY
9952 (Bulk)	10
8251	1

GM OFFSET BRACKET



P/N	BOX QTY
8509	1

OPEN GM UNIVERSAL BRACKET



P/N	BOX QTY
8510	1

GM BRACKET



P/N	BOX QTY
8015	1
8245	1
8111	1

BRACKETS

TYPICAL ASSEMBLY OF A UNIVERSAL ROD BRACKET



P/N	BOX QTY
9945	50

BELLY BANDS Individually Boxed



8637
BMW



8022
Chrysler/Dodge



8055
Chrysler/Dodge



8067
Chrysler/Dodge



8359
Chrysler/Dodge



8016
Ford



8017
Ford



8080
Ford



8085
Ford



8157
Ford



8158
Ford

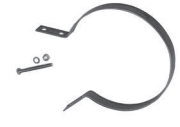

8213
Ford



8013
GM OE Style



8014
GM OE Style



8054
GM



8056
GM



8062
Late Model GM



8175
Mazda



8193
Mini Cooper



8087
Saturn



8010
Toyota



8074
Volvo



8078
Volvo



8148
Volvo

ACCESSORIES

ACCESSORIES

BRACKETS & STRAPS

UNIVERSAL BRACKET



339984
339985

P/N	TYPE	BOX QTY
339984	L-Bracket (2 1/2" x 1 1/2")	10
339985	L-Bracket (2 3/4" x 2 3/4")	50

90° STEEL STRAP With 3/8" Holes

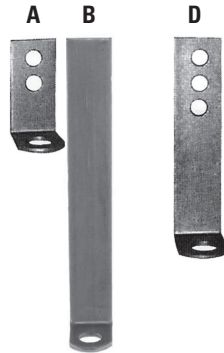

P/N	LENGTH	TYPE	BOX QTY
9928	3"	Std. D	50
339803	3"	H.D. A	25
339806	5 1/2"	H.D. A	25
339826	9"	H.D. B	25

NOTE:
Std. 1/8" Thick
H.D. 3/16" Thick

STRAIGHT STEEL STRAP With 3/8" Holes

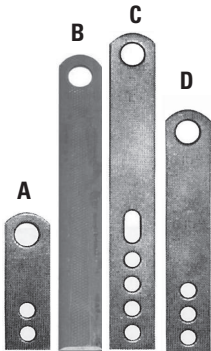

P/N	LENGTH	TYPE	BOX QTY
9923	3 1/4"	Std. A	10
9924	4 1/2"	Std. D	50
339812	4 1/2"	H.D. A	25
9925	5 3/4"	Std. D	50
339894	7"	Std. C	50
339800	8 7/8"	H.D. C	25
9926	9"	Std. D	50
339815	9"	H.D. A	25
339823	9"	H.D. B	25
339827	9"	H.D. C	25
339810	11"	H.D. A	25

NOTE:
Std. 1/8" Thick
H.D. 3/16" Thick

GM TRUCK BRACKET

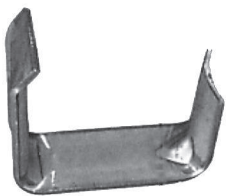

P/N	BOX QTY
9962	50
8560	1

UNIVERSAL STRAP HOOK



P/N	SIZE	TYPE	BOX QTY
8045B10	In-line	1/2" Rod	10
8046B10	90°	1/2" Rod	10
8047B10	In-line	3/8" Rod	10
8048B10	90°	3/8" Rod	10

RUBBER GROMMETS

RUBBER GROMMET SET



P/N	COLOR	TYPE	BOX QTY
F5118	Black	w/o Washer	100
F5120	Red	w/ Washer	100
F5121	Blue	Hi-Temp, w/ Washer	100

Used with 90° and straight steel strap to prevent frame rattle.

RUBBER GROMMETS (con't)

RUBBER GROMMETS



F5178

F5179

P/N	TYPE	BOX QTY
F5178	Female Grommets	100
F5179	Male Grommets	100

Used with 90° and straight steel strap to prevent frame rattle.

CLAMP-A-STUD



P/N	SIZE	BOX QTY
8028	1/4" - 1 3/4"	1
8027	1 1/4" - 2 1/4"	1
8026	2 1/4" - 3 1/4"	1

HEAT SHIELDS

UNIVERSAL MUFFLER HEAT SHIELD

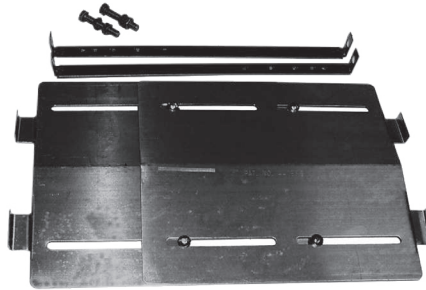

P/N	BOX QTY
9206	1

BENDABLE UNIVERSAL PIPE HEAT SHIELD

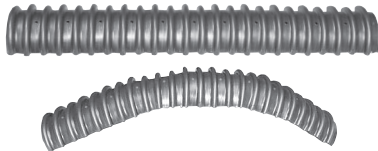

P/N	SIZE	FITS PIPE	BOX QTY
9209	18"	2 1/4" - 3" Diameter	5
9211	18"	2" Diameter and less	5

HEAT RISERS - Small Block Chevrolet V8

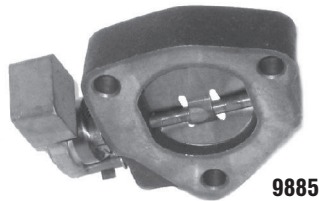

P/N 9885	(OEM #3887023)
65-75	Camaro
68-75	Chevelle
75-78	Chev/GMC Truck

NOTE: Use 8710 Gasket

The HUSH Studfix

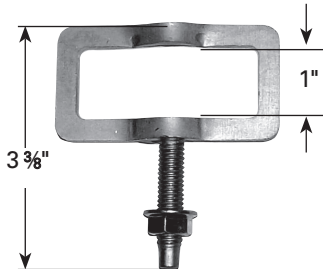

8001 - Pkg. Qty. 2
Ford Trucks

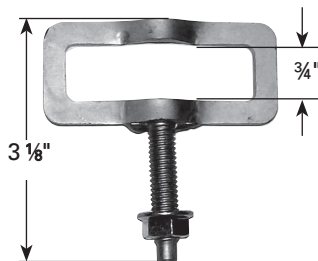

8002 - Pkg. Qty. 2
Ford Cars

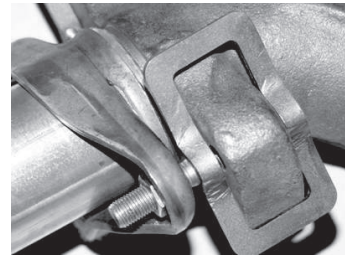

The HUSH Studfix installed

ACCESSORIES

SPLIT FLANGES & MISC.

SPLIT CONVERTER FLANGES

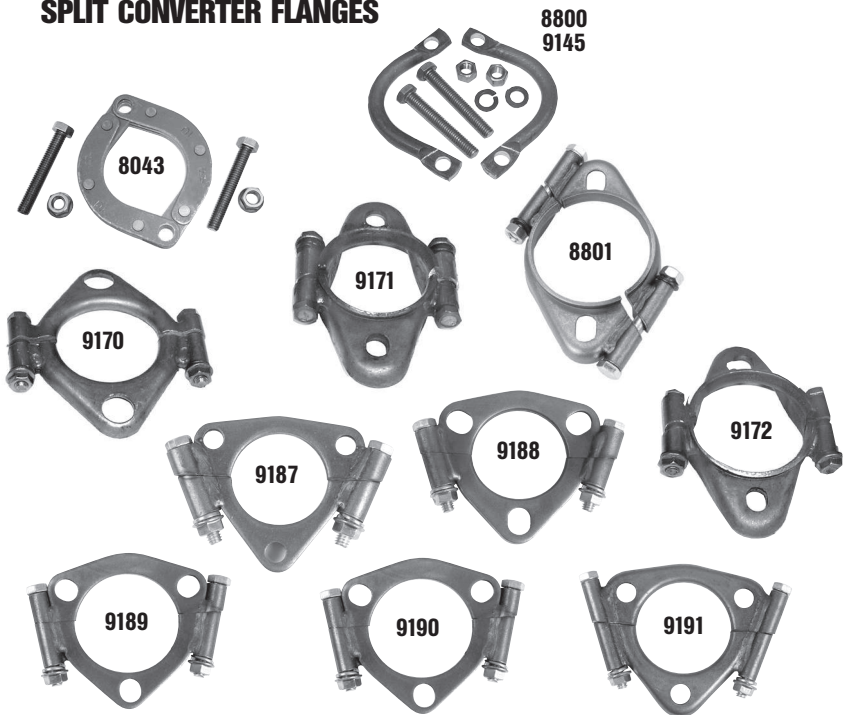

P/N	SIZE	BOX QTY	BOLT TO BOLT
9145	1 3/4" - 2"	1	3 3/16"
9187	1 7/8"	1	2 19/32"
8043	2" - 2 1/4"	1	3 5/16"
9171	2 3/32"	1	3 5/8"
9188	2 1/8"	1	2 11/16"
8800	2 1/4" - 2 1/2"	1	3 49/64"
8801	2 1/4"	1	3 5/8"
9170	2 5/16"	1	3 15/16"
9172	2 7/16"	1	3 5/8"
9191	2 7/16"	1	3 1/8"
9189	2 1/2"	1	2 15/16"
9190	2 5/8"	1	3 3/16"

SPLIT FLANGES Individually Boxed

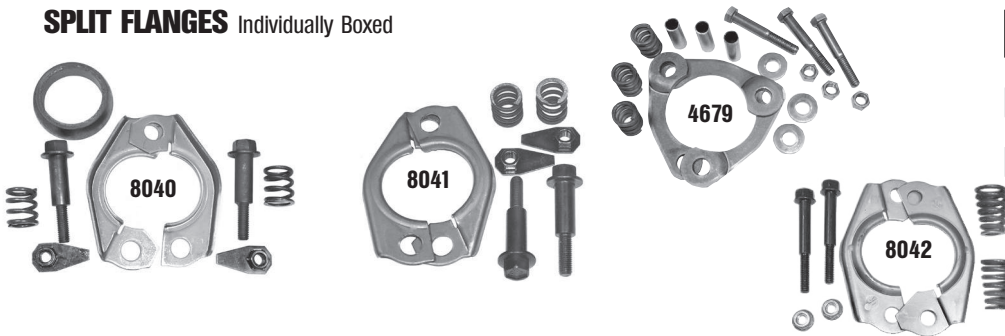

P/N	TYPE
4679	GM
8040	Ford
8041	Ford
8042	Chrysler

BOLTS, NUTS & SCREWS

HEX HEAD BOLTS – GRADE #2 & #5



P/N	SIZE	GRADE	BOX QTY
F5292	5/16" x 1 1/2"	2	100
F5229	5/16" x 2"	2	100
F5231	3/8" x 1 1/2"	2	100

Standard Thread Length



FULL Thread Length

P/N	SIZE	GRADE	BOX QTY
F5228	5/16" x 1"	2	100
F5284	5/16" x 1"	5	100
F5160	5/16" x 1 1/2"	2	100
F5306	5/16" x 2"	2	100
F5169	3/8" x 1"	2	100
F5288	3/8" x 1"	5	100
F5289	3/8" x 1 1/4"	5	100
F5307	3/8" x 1 1/2"	2	100
F5170	3/8" x 2"	2	100
F5226	3/8" x 2 1/2"	2	50
F5232	3/8" x 3"	2	50

BOLTS, NUTS & SCREWS

METRIC HEX HEAD BOLTS



P/N	SIZE	PITCH	LENGTH	THREAD	BOX QTY
F5222	8MM	1.25	40MM (Full)	Std.	100

HEX HEAD NUTS

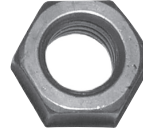

P/N	SIZE	THREAD	BOX QTY	P/N	SIZE	THREAD	BOX QTY
F5161	5/16"	Std.	100	F5240	3/8" (Flange)		100
F5163	3/8"	Std.	100	F5301	5/16" (Flange)		100
F5164	7/16"	Std.	50				

SELF TAPPING SCREWS



P/N	SIZE	BOX QTY
F5173*	5/16" x 1"	100
F5165*	5/16" x 1 1/2"	100
F5250	3/8" x 1"	100
F5251	3/8" x 1 1/2"	100

* No Point

HEX HEAD NUTS (METRIC)

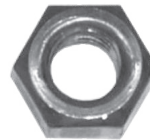

P/N	SIZE	PITCH	THREAD	BOX QTY
F5216	8MM	1.25	Std.	100
F5217	10MM	1.25	Fine	100
F5218	10MM	1.50	Std.	100
F5314	10MM	1.50	Flange	10

STUDS, WASHERS & SHIMS

MANIFOLD STUDS

With Finder Point



Without Finder Point



Standard Length

P/N	SIZE	BOX QTY
F5298	3/8" x 2"	100
F5300	3/8" x 2 1/4"	100
F5210	3/8" x 2 1/2" (w/ finder pt)	100
F5299	3/8" x 3" (w/ finder pt)	50
F5211	3/8" x 3 1/4"	50
F5254	3/8" x 3 1/2" (w/ finder pt)	50
F5209	7/16" x 2 1/2"	50
F5297	7/16" x 2 3/8" coarse, (w/ finder pt)	50

Metric Length

P/N	SIZE	BOX QTY
F5259	8MM x 1.25 x 40MM	100
F5213	10MM x 1.50 x 50MM	100
F5261	10MM x 1.25 x 42MM	100
F5262	10MM x 1.25 x 48MM	100

ACCESSORIES

STUDS, WASHERS & SHIMS

LOCK WASHERS GRADE #2



P/N	SIZE	BOX QTY
F5162	5/16"	100
F5176	3/8"	100
F5177	7/16"	100

FLAT WASHERS GRADE #2



P/N	BOLT SIZE X OD	BOX QTY
F5266	5/16" x 7/8"	100
F5267	5/16" x 9/16"	100
F5174	5/16" x 1 1/4"	100
F5268	3/8" x 1"	100
F5265	3/8" x 1 1/2"	100
F5269	3/8" x 1 3/8"	100
F5271	7/16" x 1 5/16"	100
F5270	7/16" x 1 1/4"	100

MANIFOLD SHOULDER BOLTS & SPRINGS



4678
Acura/Chrysler/
Honda/Subaru
8mm x 1.25 x 75mm



4682
Acura/Honda
(2 each per kit)
8mm x 1.25 x 64.5mm



4975
Chrysler

8mm x 1.25 x
1 3/8"



4973
Ford/Mazda
10mm x 1.50 x 70mm



4971S (Single)
GM/Ford/Mazda
4971 (10/box)



4976
GM/Chrysler

8mm x 1.25 x
1 5/8"



4680
GM/Geo/Suzuki/Toyota
10mm x 1.25 x 70mm



4970
GM/Subaru
10mm x 1.50 x 70mm



4972
GM
3/8" x 1 3/4"

MANIFOLD SHOULDER BOLTS & SPRINGS



4974
GM
10mm x 1.50 x 100mm



8037
GM



8038
GM



8039
Subaru
8mm x 6.25 x 50mm



4978
Toyota
10mm x 1.25 x 76mm



4979
Toyota



F5309
Universal Spring
(10 per box)



4936
Mounting Kit
(Complete)
Lexus, Mitsubishi, Nissan,
Pontiac, Scion, Toyota

JOINT CONNECTOR

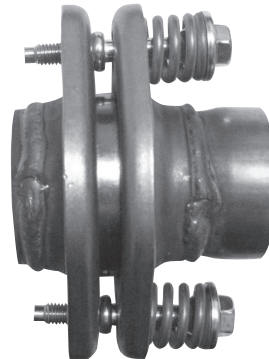

JOINT CONNECTOR

P/N	DESCRIPTION
8802	Fits 1 3/4" and 2" pipes 8435 Gasket included. Stainless Steel

ACCESSORIES

ACCESSORIES

OXYGEN SENSOR ACCESSORIES

4961

18 mm Male O2 Sensor Plug
10 per box



4962

18 mm Female O2 Sensor Boss
10 per box



4751

18 mm Female O2 Sensor Boss, 45 Deg. cut
10 per box



4752

12 mm Female O2 Sensor Boss
10 per box



4753

Toyota, Lexus, GEO, Mitsubishi, Subaru, Chrysler Imports:
2 Bolt O2 sensor Boss
10 per box



AIR TUBE REPLACEMENTS

4948

UNIVERSAL AIR TUBE KIT - SINGLE

Fits 1/2" & 3/4" Air Tubes
Allows for easy connection from OEM air tube to aftermarket converter.

INCLUDES: 12" of 3/4" High Temp. Hose,
(2) Hose Clamps, (2) High Temp.
Thermo Plastic Hose Size Adapters.



4949

UNIVERSAL AIR TUBE KIT - (6) PER/BOX

HIGH TEMP - REPLACEMENT HOSE

HIGH TEMP HOSES-FOR USE IN AIR INJECTION SYSTEM REPAIRS.



1/2" I.D. DIAMETER

4754 - 12" Length

4937 - Bulk 10' Length

5/8" I.D. DIAMETER

4756 - 12" Length

4757 - Bulk 10' Length

3/4" I.D. DIAMETER

4758 - 12" Length

4938 - Bulk 10' Length

UNIVERSAL & SPECIAL APPLICATION FLANGES

3-HOLE UNIVERSAL FLANGE



P/N	SIZE	BOX QTY
9152	2"	10
9152S	2"	1
9124	2 ²³ / ₆₄ "	1
8032	2 ⁵ / ₈ "	1
8033	3 ¹ / ₁₆ "	1

2-HOLE UNIVERSAL FLANGE



P/N	SIZE	BOX QTY
9153	1 ³ / ₄ "	10
9153S	1 ³ / ₄ "	1
8036	1 ³ / ₄ "	1

Note: 9153, 9153S - ⁵/₁₆" thick
8036 - ³/₈" thick

2-HOLE UNIVERSAL FLANGE



P/N	SIZE	BOX QTY
9154	2 ¹ / ₈ "	10
9154S	2 ¹ / ₈ "	1

2-HOLE UNIVERSAL FLANGE



P/N	SIZE	BOX QTY
9155	2 ⁵ / ₁₆ "	10
9155S	2 ⁵ / ₁₆ "	1
8035	2 ³ / ₈ "	1

2-HOLE UNIVERSAL FLANGE



P/N	SIZE	BOX QTY
9156	2 ⁹ / ₁₆ "	10
9156S	2 ⁹ / ₁₆ "	1

3-HOLE UNIVERSAL FLANGE



P/N	SIZE	BOX QTY
9158	2 ⁵ / ₁₆ "	10
9158S	2 ⁵ / ₁₆ "	1

OEM STYLE FLANGE - FORD



P/N	SIZE	BOX QTY
8029	2 ⁹ / ₁₆ "	1

OEM STYLE FLANGE - FORD



P/N	SIZE	BOX QTY
8030	2 ¹ / ₁₆ "	1

OEM STYLE FLANGE - FORD



P/N	SIZE	BOX QTY
8031	2 ⁵ / ₁₆ "	1

ACCESSORIES

EXHAUST PIPE FLANGE CHARTS

ACCESSORIES

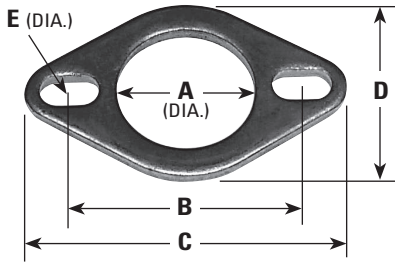

P/N	A	B	C	D	E
8035	2 3/8"	3 7/8"	5 1/4"	3 1/2"	1/2" x 7/8" slot
8036	1 3/4"	3 1/2"	4 3/4"	3"	1/2" x 3/4" slot
8788	2"	3"	4"	2 3/4"	1/2"
8793	2 3/32"	3 1/2"	5"	3 1/32"	7/16"
9122	1 5/8"	2 7/8"	3 7/8"	2 5/8"	7/16" x 3/4" slot
9128	2 3/32" *	3 1/8"	5"	3 1/32"	1/2" x 29/32" slot
9153#	1 3/4"	3 1/2"	4 3/4"	3"	1/2" x 3/4" slot
9153S	1 3/4"	3 1/2"	4 3/4"	3"	1/2" x 3/4" slot
9154#	2 1/8"	3 1/2"	4 3/4"	3"	1/2" x 3/4" slot
9154S	2 1/8"	3 1/2"	4 3/4"	3"	1/2" x 3/4" slot
9155#	2 5/16"	3 7/8"	5 1/4"	3 1/2"	1/2" x 7/8" slot
9155S	2 5/16"	3 7/8"	5 1/4"	3 1/2"	1/2" x 7/8" slot
9156#	2 9/16"	3 7/8"	5 1/4"	3 1/2"	1/2" x 7/8" slot
9156S	2 9/16"	3 7/8"	5 1/4"	3 1/2"	1/2" x 7/8" slot
9175	1 7/8"	3 1/16"	4 1/4"	2 3/4"	9/16" x 1 1/16" slot
9176	2 1/16"	3 1/16"	4 1/4"	2 3/4"	9/16" x 1 1/16" slot
9179	2 1/16"	3 1/2"	4 7/8"	3 1/16"	7/16" x 7/8" slot
9181	2"	3 1/2"	4 3/4"	3"	1/2" x 3/4" slot
9184	2 1/8"	3"	4"	2 3/4"	1/2"
9185	2 1/4"	3 7/16"	4 1/2"	3"	1/2"

* w/chamfer

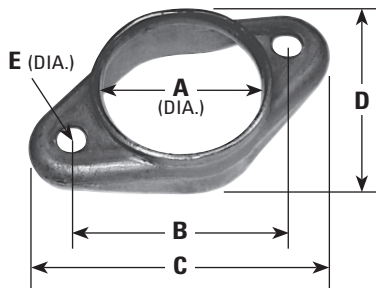

P/N	A	B	C	D	E
8777	2 7/16"	3 5/8"	5"	2 7/8"	7/16" x 9/16" slot
8786	2 7/16"	3 3/4"	5 1/8"	2 15/16"	7/16"
8792	2 1 1/16"	3 3/4"	5 1/4"	2 7/8"	7/16"
8796	2 1/4"	3 9/16"	5"	2 3/4"	3/8" x 7/16" slot
8798	2 1/8"	3 3/4"	5 1/8"	2 3/8"	7/16"
9147	2 5/16"	4"	5 3/8"	3 3/8"	13/16"
9150	2 1/8"	3 5/8"	4 3/4"	2 9/16"	7/16" x 9/16" slot
9162	2 5/8"	4 3/4"	6 1/8"	3"	7/16"
9166	3 1/2"	4 1/4"	6 5/64"	3 3/16"	7/16"
9167	2 1/2"	4"	5 3/8"	3 3/8"	3/4"

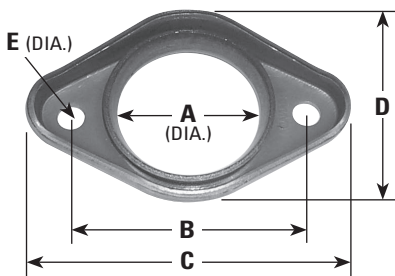

P/N	A	B	C	D	E
8789	2 1/16"	3 1/8"	4 1/8"	3 1/4"	1/2"
9140	2 1/4"	4"	5 7/16"	3 3/8"	7/16"
9164	2 9/16"	3 15/16"	5 1/8"	3 7/16"	23/32"

Bulk Packed 10/Box

EXHAUST PIPE FLANGE CHARTS

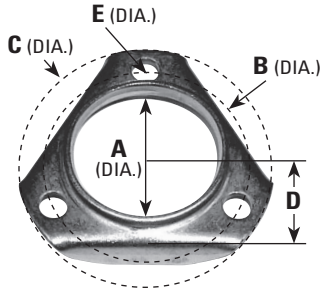

P/N	A	B	C	D	E
8780	2 1/8"	3 1/8"	3 7/8"	1 7/16"	7/16"

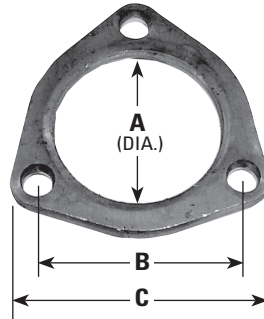

P/N	A	B	C
8032	2 5/8"	3 3/16"	3 7/8"
8033	3 1/16"	3 5/16"	4 1/8"
8034	2 5/8"	3 1/16"	3 7/8"
8799	2 7/16"	2 13/16"	3 5/8"
9124	2 23/64"	3 1/16"	3 7/8"
9152#	2"	2 11/16"	3 3/4"
9152S	2"	2 11/16"	3 3/4"
9158#	2 5/16"	2 11/16"	3 15/16"
9158S	2 5/16"	2 11/16"	3 15/16"
9173	2 1/2"	3 1/8"	3 15/16"
9177	2 1/8"	2 11/16"	3 5/8" (rad.)
9178	2 5/8"	3 1/16"	3 7/8"
9180	3 1/16"	3 5/16"	4 1/8"

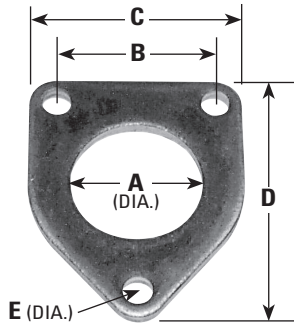

P/N	A	B	C	D	E
9174	2"	2 7/16"	3 3/8"	4 3/16"	7/16"

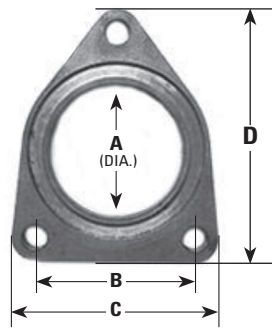

P/N	A	B	C	D
9120	2 17/32" *	3"	3 7/8"	4 3/4"

* w/chamfer

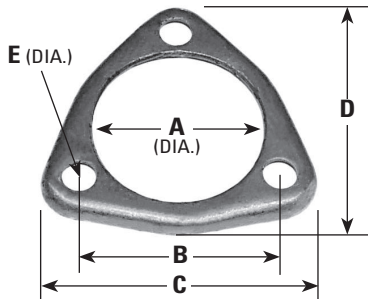

P/N	A	B	C	D	E
8775	2 5/16"	2 7/8"	4 5/16" (rad.)	4 1/2" (rad.)	7/16"
8787	2 11/16"	3 1/8"	4 5/16" (rad.)	4 1/8" (rad.)	1/2"
9146	2 5/8"	3 1/2"	4 33/64" (rad.)	4 19/64" (rad.)	27/64"

Bulk Packed 10/Box

EXHAUST PIPE FLANGE CHARTS

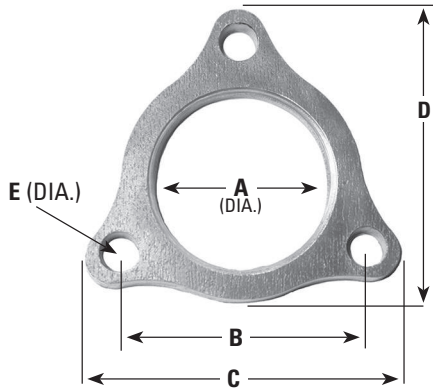

P/N	A	B	C	D	E
9113	2 3/4"	3 13/32"	5"	4 3/4"	1/2"

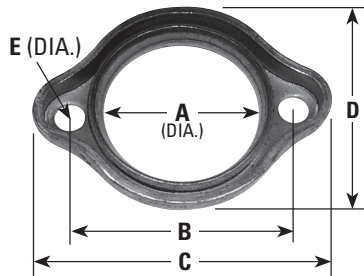

P/N	A	B	C	D	E
8029	2 9/16"	3 3/4"	4 15/16"	3 9/16"	1/2"
8030	2 1/16"	3 1/2"	4 5/8"	3 3/8"	1/2"
8031	2 5/16"	3 13/16"	4 15/16"	3 9/16"	1/2"
8778	2 7/16"	4 1/16"	4 1/2"	3 9/16"	9/16"
8781	2 1/8"	3 1/8"	4 1/4"	3 1/4"	7/16"

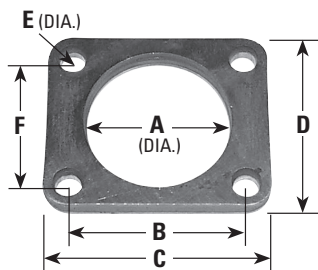

P/N	A	B	C	D	E	F
9143	2 9/16"	2 13/16"	3 9/16"	3 1/4"	3/8"	2 7/16"
9586	4 1/8"	4 3/16"	6"	6"	5/8"	4 3/16"

Bulk Packed 10/Box

EXHAUST GASKET CHARTS

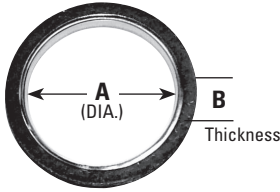

GASKET NO.	A	B
8421	3 3/32"	3/16"
8449	3 13/32"	7/32"
8470	2 13/16"	5/32"
8690	1 3/4"	3/16"
8731°	2"	1/16"
8733	1 15/16"	5/32"
8737	2 5/32"	3/16"
8749	1 13/16"	3/16"
8764°	5 9/64"	3/16"
8770	1 9/16"	3/16"
9016	2 3/8"	3/16"
9024	1 31/32"	3/16"
9026	2 19/32"	3/16"
9027	2 3/16"	1/8"
9066	1 7/8"	3/16"
9100	2 1/16"	1/16"
9207	2 31/32"	3/16"
9218°	2 3/4"	3/16"
9233	2 1/32"	15/32"
9282	2 3/8"	3/16"

° Metal with Fiber Core

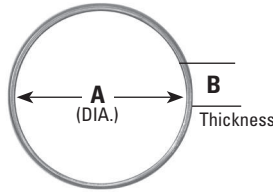

GASKET NO.	A	B
8352	3 3/32"	1/32"
8375	4 53/64"	5/32"
8376	3 7/16"	11/64"
8421	3 3/32"	1/4"
8424	2 7/16"	5/32"
8437	4 7/32"	1/8"
8457	2 29/32"	11/64"
8467	2 9/16"	5/32"
8469	3 3/16"	5/32"
8622	3 31/32"	3/16"
8676	2 35/64"	3/16"
8693	2"	3/16"
8702	2 9/32"	3/16"
8727	2 3/4"	11/64"
8762	2 13/16"	5/32"
9044	2 13/32"	7/32"
9059	2 5/8"	3/16"
9061	2"	1/8"
9080	2 3/32"	5/32"
9252	1 13/16"	3/16"
9267	1 7/8"	3/16"
9268	2 7/32"	5/32"

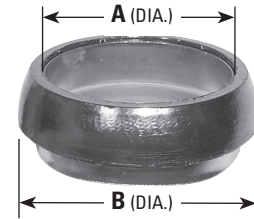

GASKET NO.	A	B
8408	2 5/16"	3 1/8"
8418	2 17/32"	3 7/16"
8444	2 5/16"	3"
8644	2 17/32"	3 7/16"
8699 ²	2 1/8"	2"
8763	2 1/8"	2 1/8"
8769	1 29/32"	1 7/8"
9051	2 3/8"	2 5/8"
9052	2 1/8"	2 3/8"
9091 ¹	1 11/16"	1 7/8"
9093 ³	1 15/16"	2 1/4"
9212	1 27/32"	2"
9220 ³	1 3/4"	2"
9234	2 1/16"	2 13/32"
9259	2"	2 1/2"
9260	2 3/8"	3 3/16"
9261	2 1/4"	2 1/2"
9272	2 1/8"	2 1/2"

¹ Graphoil Material

² Sintered Iron Material

³ Metal Mesh Material

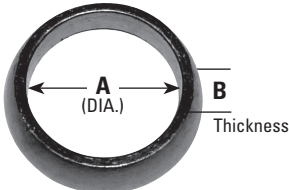

GASKET NO.	A	B
8332	2 3/16"	1/2"
8333	2"	33/64"
8406	2 9/16"	11/16"
8410	1 1/2"	1/2"
8411	2 3/8"	37/64"
8415	2 3/8"	11/16"
8423	2 3/16"	11/16"
8425	2 31/32"	45/64"
8427	2 9/32"	1/2"
8434	1 23/32"	3/8"
8443	1 31/32"	9/16"
8458	1 55/64"	15/32"
8460	2 27/32"	1/2"
8473	2 17/32"	9/16"
8482	1 25/32"	21/32"

GASKET NO.	A	B
8490	2 13/32"	27/64"
8623	2 3/8"	3/4"
8695 ³	2 9/32"	5/8"
8706 ¹	1 25/32"	1/2"
8755 ³	2 3/4"	33/64"
8756	1 15/16"	29/64"
9002	2 3/16"	5/8"
9019	2 1/8"	5/8"
9056 ²	2 1/8"	1/2"
9082 ¹	2 13/16"	19/32"
9084 ²	2 1/8"	3/4"
9087 ¹	2"	1/2"
9090 ¹	2"	5/8"
9094 ¹	1 3/4"	9/16"
9095 ¹	2 5/16"	5/8"
9215	1 29/32"	21/32"
9216	2 3/8"	5/8"
9221 ¹	2 1/4"	1/2"
9225 ³	2 5/16"	11/16"

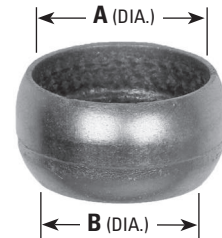

GASKET NO.	A	B
8435	2 1/8"	2"
8683	2 17/64"	1 23/64"

9231 ³	2"	9/16"
9240 ¹	1 11/16"	1/2"
9248 ³	2 1/2"	15/32"
9257	2 5/32"	21/32"
9264 ¹	2 1/16"	5/8"
9290 ¹	1 29/32"	5/8"

¹ Graphoil Material ² Sintered Iron Material

³ Metal Mesh Material

ACCESSORIES

EXHAUST GASKET CHARTS

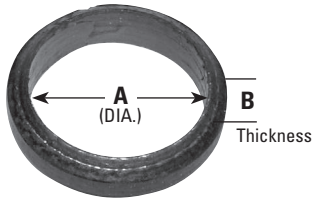

GASKET NO.	A	B
8420 ²	2 ¼"	9/16"
8440	1 13/32"	5/8"
8715	1 7/8"	5/8"
8717	2 1/32"	5/8"
8738	2 ½"	5/8"
8740 ²	1 13/16"	9/16"
8744	2 1/8"	¾"
8767 ³	2 3/8"	7/8"
8773	2 ¼"	5/8"
9001	1 7/8"	9/16"
9005	1 31/32"	9/16"
9007	2 1/32"	¾"
9008	1 15/16"	9/16"
9017 ^{2,3}	2 9/32"	15/32"
9038 ^{3,4}	1 ¾"	3/8"
9055	1 ¾"	5/8"
9057 ^{3,4}	1 5/8"	3/8"
9083 ^{3,4}	2"	½"
9086 ²	2 7/32"	5/8"
9118	2 9/16"	½"
9217 ^{2,3}	2 13/32"	13/16"

² Sintered Iron Material
³ For Spherical Flare Use
⁴ Formed Metal Material

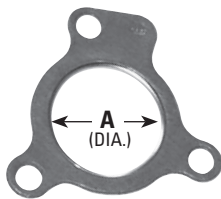

GASKET NO.	A
9047	1 13/16"
9247	2 1/32"

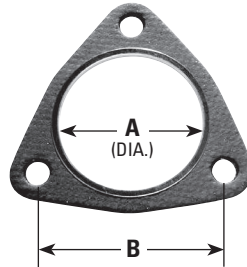

GASKET NO.	A	B
8403	3 9/32"	4 15/32"
8441	2 3/8"	2 ¾"
8442	3 5/32"	3 3/8"
8451	3 9/16"	3 7/8"
8677	2 5/32"	2 3/8"
8681	2 5/8"	3 3/16"
8691	2 7/16"	3 9/32"
8705+	2 1/16"	2 15/16"
8710	2 3/32"	2 ¾"
8711	2 9/16"	3"

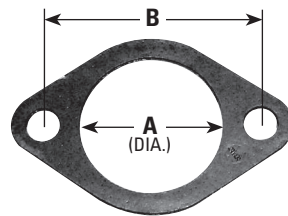

GASKET NO.	A	B
8290 ⁵	2 7/32"	3 39/64"
8405	2 ¼"	4"
8412 ⁵	2 19/32"	4 3/32"
8426	2 ¼"	4 1/32"
8428+	2 5/64"	3 ½"
8430+	1 13/16"	3"
8454+	2 19/64"	3 7/8"
8455+	2 13/32"	3 3/8"
8456+	2 19/32"	3 5/16"
8459+	2 5/32"	3 1/8"
8672	2 51/64"	4 13/32"
8674	2 31/32"	4 5/8"
8688	2 13/32"	3 15/16"
8689	2 3/8"	3 5/8"
8692	2 1/8"	4"
8697	2"	3 3/8"
8703+	1 49/64"	3"
8704+	2"	3 1/8"
8707+	1 7/8"	3 ¾"
8714	1 31/32"	2 15/16"
8719	1 15/16"	3 1/8"
8722	1 31/32"	3 ¼"
8724	2 5/16"	3 ½"
8726	2 3/16"	3"

GASKET NO.	A	B
8720	2 3/32"	2 ¾"
8730	2 11/32"	2 13/16"
8739	1 13/16"	2 5/8"
8743+	2 13/64"	1/16"
9000	2 3/16"	3 ½"
9018	2 19/32"	3 ½"
9030	1 7/8"	2 5/8"
9031	2 ¼"	2 7/8"
9039	2 13/16"	3 ¼"
9040	2 13/16"	3 5/16"
9042	2 31/32"	3 1/8"
9068	2 1/8"	3 7/8"
9214	1 13/16"	3 29/32"
9278	2 5/32"	2 15/16"
9280	3 1/16"	4 7/16"
9283	2 5/16"	3 1/8"
9287	2 13/16"	4 5/16"

+ Slotted Bolt Hole

GASKET NO.	A	B
8729	2 9/16"	3 11/16"
8735#	1 13/16"	3 1/8"
8735S	1 13/16"	3 1/8"
8741	1 31/32"	3 3/8"
8742	2 15/32"	3 7/8"
8751	1 13/16"	3"
8768	2"	3 ½"
8771+	2 ½"	4"
8772+	2 5/16"	3 ½"
8807 ⁵	2 13/16"	4 3/8"
9033	1 13/16"	2 19/16"
9064	1 27/32"	2 59/64"
9072	2 1/16"	3 5/32"
9075	2"	3"
9079+	2 5/8"	4 ¼"
9081	2"	3 3/16"
9088	1 27/32"	5 ¼"
9099	2 ½"	4 1/8"
9238	2 ¼"	3 ½"
9250	2 1/16"	4 5/16"
9256	2 3/8"	4 5/16"
9258+	1 13/16"	3 3/8"
9270	2 21/32"	4 1/16"
9274	2 5/16"	4 1/8"
9275	2 ¼"	3 7/8"
9277	1 15/16"	3 5/8"
9279	2 ¼"	3 5/8"
9284	3 1/16"	5 5/32"
9288	2 23/32"	4 7/16"

+ Slotted Bolt Hole
Bulk Packed 10/Box
⁵ Tin Plate With Insert

EXHAUST GASKET CHARTS

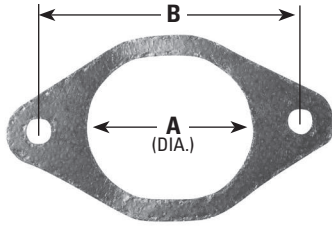

GASKET NO.	A	B
8422	2 7/8"	4 9/16"

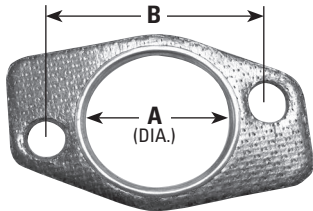

GASKET NO.	A	B
8407	1 27/32"	2 15/16"

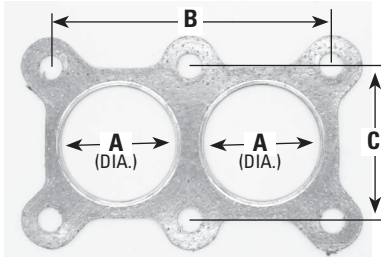

GASKET NO.	A	B	C
9213*	2 3/32"	5 1/16"	2 3/4"

* Hi-temp Graphite

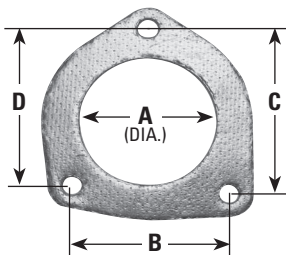

GASKET NO.	A	B	C	D
8414	2 9/16"	2 13/16"	3 9/16"	3 3/8"

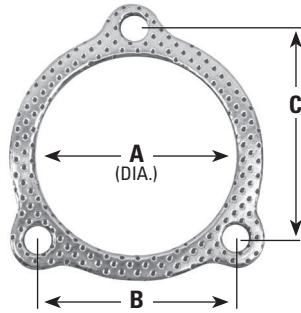

GASKET NO.	A	B	C
8611	2 7/8"	2 3/4"	3 3/8"

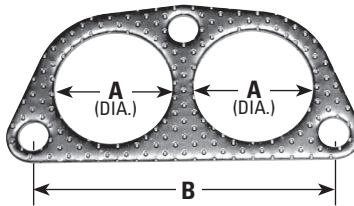

GASKET NO.	A	B
8463	2"	5"
8696	1 3/4"	4 3/16"
8734	1 11/16"	4"
9022	1 27/32"	4 13/32"
9237	1 1/2"	3 15/16"
9253	1 3/4"	4 5/16"
9286+	2 9/16"	7 11/16"

@ Holes Connect

+ Slotted Bolt Hole

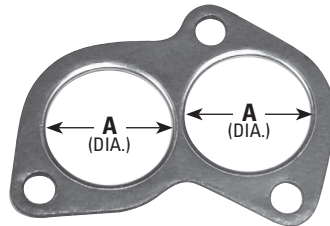

GASKET NO.	A
8750	1 3/16"

+ Slotted Bolt Hole

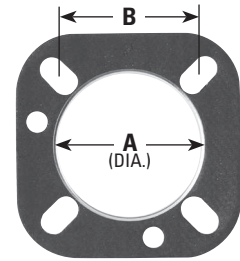

GASKET NO.	A	B
9069	2 29/32"	2 15/16"
9070	3 3/8"	3 7/16"

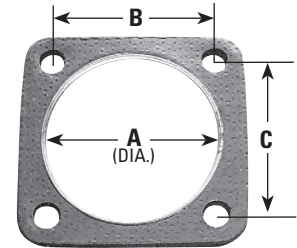

GASKET NO.	A	B	C
8481	3"	3 1/4"	3 1/4"
8759	3 3/32"	2 29/32"	4 31/64"
9025	2 15/16"	2 3/8"	2 3/8"
9058	2 3/4"	2 1/2"	2 3/4"
9226	2 1/2"	2 13/16"	2 1/2"

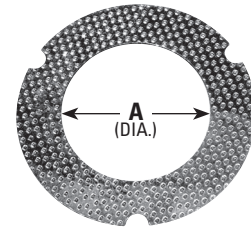

GASKET NO.	A
9223	2 5/8"

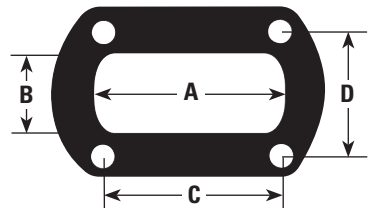

GASKET NO.	A	B	C	D
9245	5 9/16"	2 5/16"	4 9/16"	4 1/4"

EXHAUST GASKET CHARTS

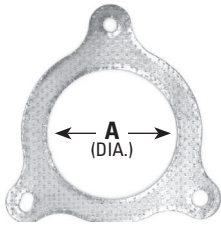

GASKET NO.	A
8694	2 13/16"

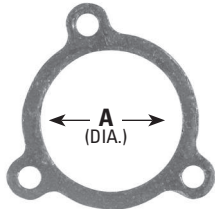

GASKET NO.	A
8680	3 3/16"

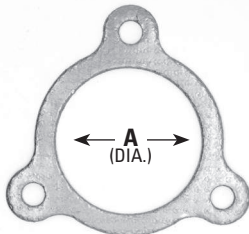

GASKET NO.	A
8747	2 5/8"

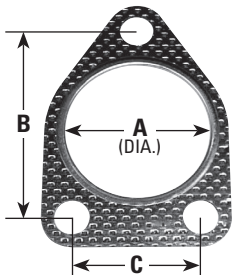

GASKET NO.	A	B	C
8439	2 1/2"	4"	2 43/64"
8453	2 1/4"	3 3/32"	2 23/32"
8701+*	2 1/16"	2 7/8"	2 1/2"
8760	1 13/16"	3 1/4"	2 1/2"
9043	2"	3 1/8"	2 5/16"
9097	2 3/32"	2 15/16"	1 13/16"
9239	2 1/4"	3 3/16"	1 15/16"
9269	2 5/8"	3 5/8"	2 5/16"

+ Slotted Bolt Hole

* Hi-temp Graphite

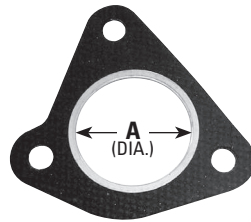

GASKET NO.	A
8712	2 3/32"

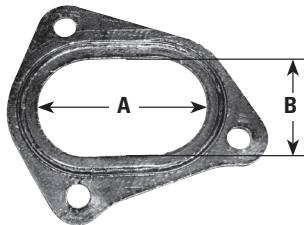

GASKET NO.	A	B
9263	3 7/16"	2 3/16"
8708+	3 25/32"	2 17/32"

+ Slotted Bolt Hole

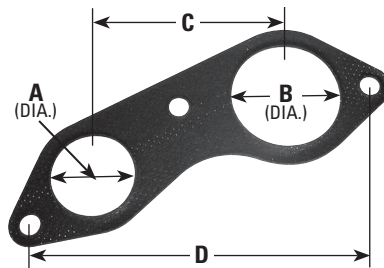

GASKET NO.	A	B	C	D
4731	3 5/32"	3 23/32"	5 5/8"	9 15/16"
9285	2 1/16"	2 3/4"	5 1/4"	9 5/32"

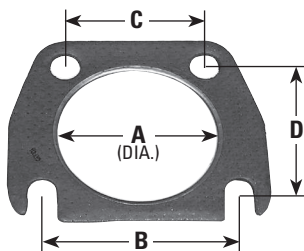

GASKET NO.	A	B	C	D
8682	2 1/16"	2 11/16"	1 15/16"	2 3/16"
9014	2"	3 3/16"	2 3/8"	2 5/8"
9015	2 5/8"	3 3/16"	2 3/8"	2 5/8"

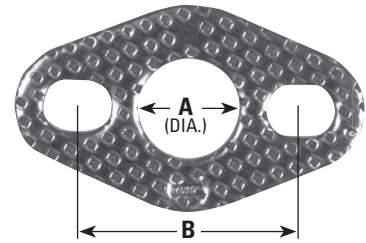

GASKET NO.	A	B
9291+	3/4"	1 11/16"
9299	3/4"	2 1/8"

Airtibe / O2 Sensor Gasket

+ Slotted Bolt Hole

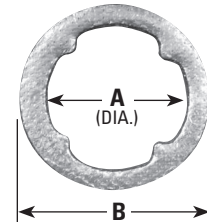

GASKET NO.	A	B
9266	2 9/16"	3 1/2"

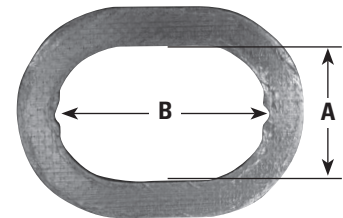

GASKET NO.	A	B
8725	2 7/32"	3 3/8"

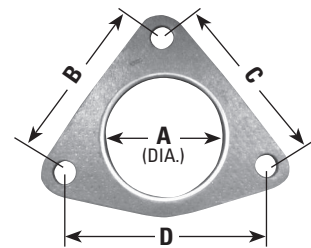

GASKET NO.	A	B	C	D
8468	2 9/16"	4 29/32"	4 29/32"	4 1/2"
9276	2 7/16"	3 1/2"	3 1/2"	4 1/4"

EXHAUST GASKET CHARTS

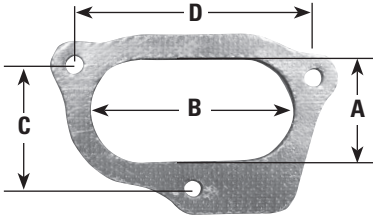

GASKET NO.	A	B	C	D
9271	2 1 ¹ / ₃₂ "	4 3 ¹ / ₄ "	2 1 ¹⁵ / ₁₆ "	5 9 ¹ / ₁₆ "

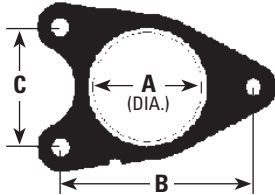

GASKET NO.	A	B	C
8728	2 3 ¹ / ₄ "	5 3 ¹⁵ / ₁₆ "	3 1 ¹ / ₈ "

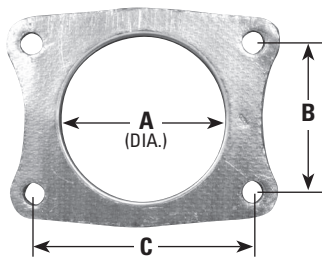

GASKET NO.	A	B	C
9119	3 1 ¹ / ₂ "	3 3 ¹ / ₄ "	4 5 ⁷ / ₆₄ "

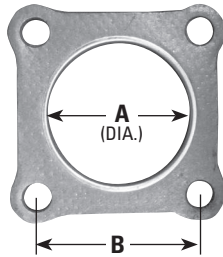

GASKET NO.	A	B
9011	2 1 ¹¹ / ₃₂ "	2 1 ¹³ / ₁₆ "
9289	2 5 ¹ / ₈ "	3 1 ¹ / ₄ "

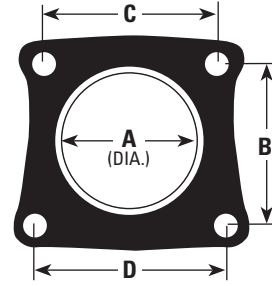

GASKET NO.	A	B	C	D
8721	2 5 ¹ / ₈ "	2 4 ⁵ / ₆₄ "	3 2 ¹ / ₃₂ "	4 9 ¹ / ₆₄ "

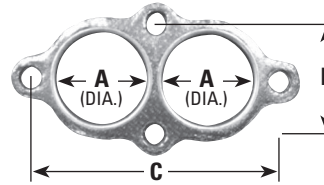

GASKET NO.	A	B	C
8401	1 2 ⁷ / ₃₂ "	2 1 ¹ / ₄ "	5 1 ¹ / ₈ "

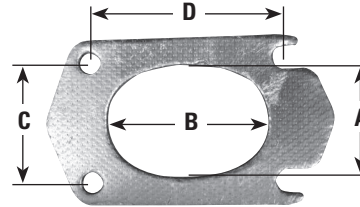

GASKET NO.	A	B	C	D
8761	2 1 ¹ / ₂ "	3 3 ¹⁵ / ₁₆ "	2 3 ¹ / ₄ "	4 3 ¹ / ₈ "

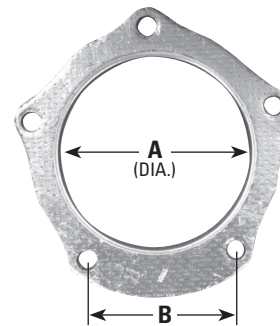

GASKET NO.	A	B
8409	4"	2 7 ¹ / ₈ "
8723	3 1 ¹⁷ / ₃₂ "	2 1 ¹³ / ₁₆ "
9096	4 1 ¹⁹ / ₃₂ "	3 3 ¹ / ₁₆ "
9254	4 1 ¹ / ₁₆ "	3 1 ¹ / ₈ "

EXHAUST GASKET CHARTS

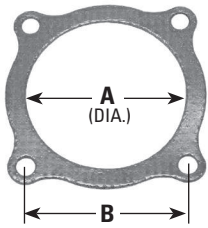

GASKET NO.	A	B
8417	3 9/16"	3 7/32"
8433	4"	3 57/64"

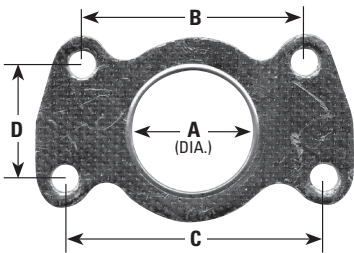

GASKET NO.	A	B	C	D
9054	2"	3 3/4"	4 5/16"	1 15/16"

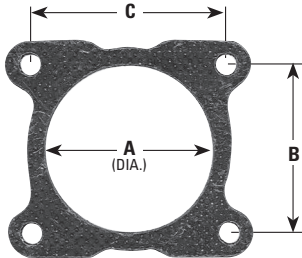

GASKET NO.	A	B	C
8436	3"	3"	3 1/2"

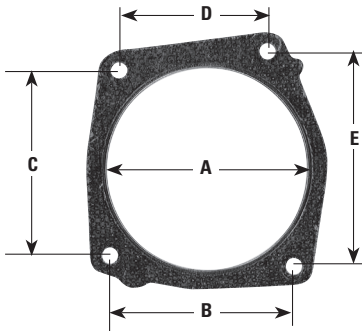

GASKET NO.	A	B	C	D	E
8452	4 49/64"	4 1/4"	4 1/4"	3 1/2"	5"

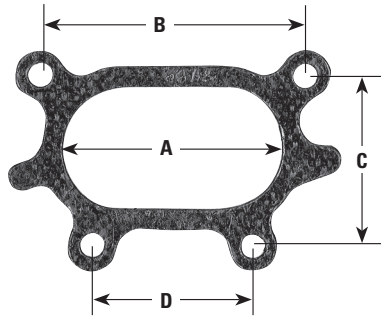

GASKET NO.	A	B	C	D
8480	3 1/4"	3 15/16"	2 1/2"	2 3/8"
8502*	3 5/8"	4 1/4"	2 5/8"	2 1/2"

*No Side Tabs

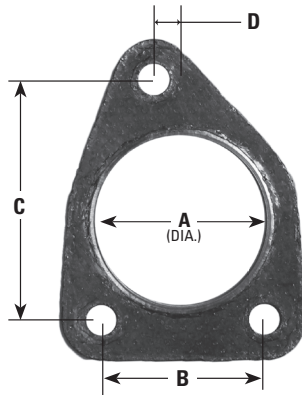

GASKET NO.	A	B	C	D
8685	2 1/4"	2 7/32"	3 3/16"	3/8"

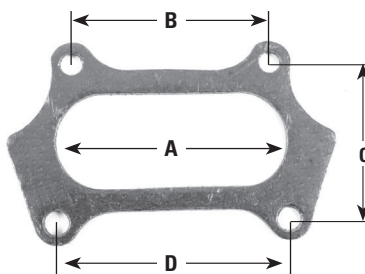

GASKET NO.	A	B	C	D
8514	3 11/16"	3 7/32"	2 17/32"	3 11/16"

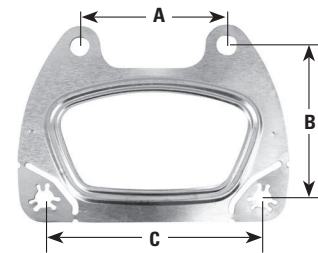

GASKET NO.	A	B	C
8284	2 13/16"	2 7/8"	4"

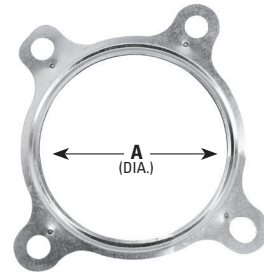

GASKET NO.	A
8612	3 15/32"

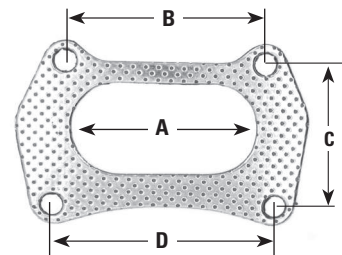

GASKET NO.	A	B	C	D
8716	3 5/16"	3 7/16"	2 1/2"	3 15/16"

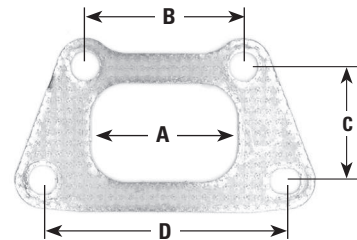

GASKET NO.	A	B	C	D
8709	2 11/16"	2 13/16"	2 1/16"	4 5/16"

EXHAUST GASKET CHARTS

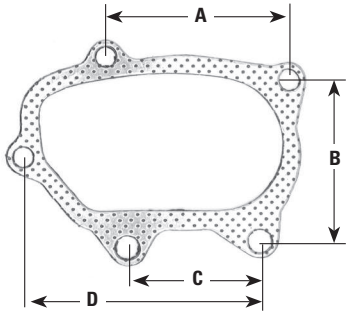

GASKET NO.	A	B	C	D
8419	3 5/8"	3 1/8"	2 5/8"	4 5/8"

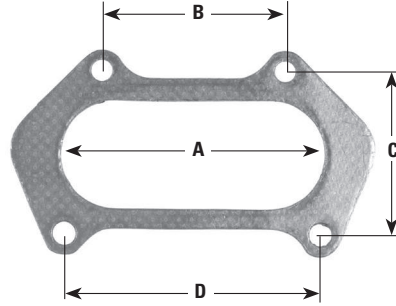

GASKET NO.	A	B	C	D
8271	4 7/16"	3 1/8"	2 3/4"	4 3/8"

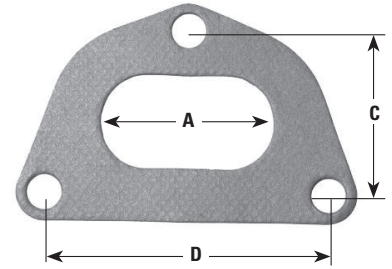

GASKET NO.	A	B	C
8752	2 7/8"	4 3/8"	2 9/16"

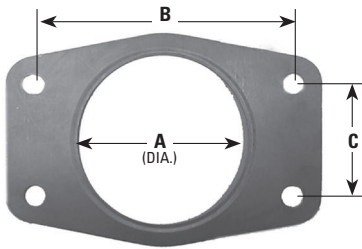

GASKET NO.	A	B	C
8753	2 15/16"	4 3/8"	1 7/8"

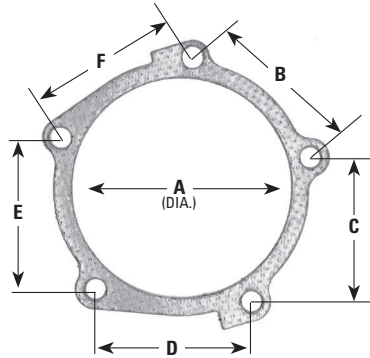

GASKET NO.	A	B	C	D	E	F
8686	4 3/32"	2 3/8"	2 11/32"	2 23/32"	2 7/8"	2 25/32"

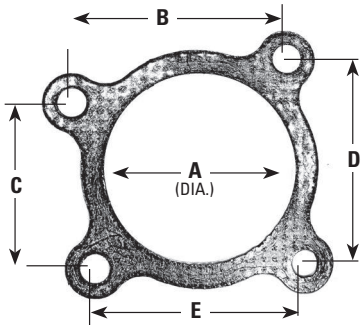

GASKET NO.	A	B	C	D	E
8416	3 7/16"	3 3/4"	3 3/4"	4"	3"

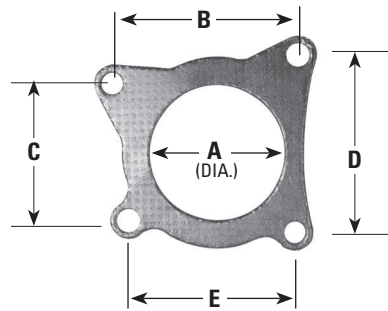

GASKET NO.	A	B	C	D	E
8746	3 3/8"	4 3/16"	3 7/16"	4 7/16"	4 5/8"

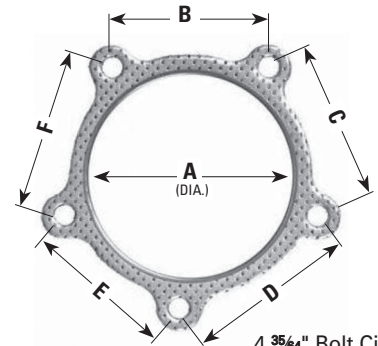

GASKET NO.	A	B	C	D	E	F
8684	3 5/16"	2 5/8"	2 5/8"	2 9/16"	2 13/16"	2 3/4"

ELBOWS

WELDING OF ALUMINIZED MATERIAL

Gas Welding

1. Adjust gases until there is a small soft blue flame extending beyond the inner cone $\frac{1}{8}$ " to $\frac{1}{4}$ ".
2. Use an AWS (American Welding Society) Number ER 70S-2 welding rod or the equivalent. This rod has extra elements added to cause the aluminized coating to float on top of the molten puddle away from the inner weld structure.

Tig Welding

Use the same type welding rod as gas welding with argon purge gas.

Mig Welding

For typical exhaust components, use a copper clad, .035 inch to .045 inch diameter wire. Specifically use a low carbon steel wire, AWS Number 70S-3 or the equivalent.

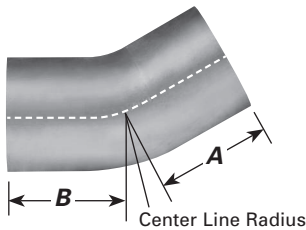

ALUMINIZED 15° ELBOWS

Both ends are O.D.

P/N	DIAMETER	LENGTH A-B	CENTERLINE RADIUS
10684	4"	2"-2"	4 ½"
10685	5"	4"-4"	8"

ALUMINIZED 30° ELBOWS

One end is I.D., the other end is O.D.

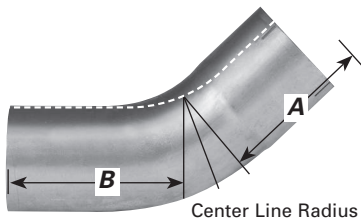

P/N	DIAMETER	STYLE	LENGTH A-B	CENTERLINE RADIUS
10631	3 ½"	ID-OD	4"-4"	5"
10632	4"	ID-OD	4"-4"	5"
10633	5"	ID-OD	4"-4"	6"

Both ends are O.D.

P/N	DIAMETER	STYLE	LENGTH A-B	CENTERLINE RADIUS
10636	4"	OD-OD	4"-4"	5"
10637	5"	OD-OD	4"-4"	6"

ELBOWS

ALUMINIZED & CHROME 45° ELBOWS

One end is I.D., the other end is O.D.

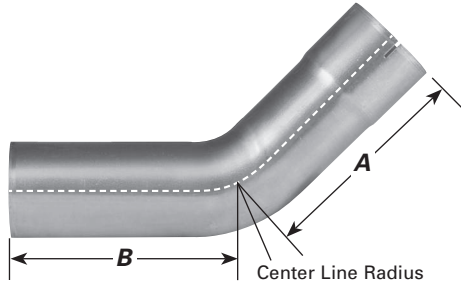

P/N ALUMINIZED	P/N CHROME	DIAMETER	STYLE	LENGTH A-B	CENTERLINE RADIUS
10311	—	2"	ID-OD	6"-6"	5"
10320	—	2 ¼"	ID-OD	6"-6"	4 ½"
10312	—	2 ½"	ID-OD	6"-6"	4"
10725	—	2 ½"	ID-OD	6"-6"	5"
10318	—	2 ¾"	ID-OD	6"-6"	5"
10313	—	3"	ID-OD	7"-7"	6"
10314	—	3 ½"	ID-OD	8"-8"	7"
10736	—	4"	ID-OD	5"-5"	4"
10726	—	4"	ID-OD	6"-6"	6"
10315	—	4"	ID-OD	9 ¼"-9 ¼"	8"
10727	—	4"	ID-OD	12"-12"	6"
10729	—	5"	ID-OD	7"-7"	8"
10730	809738	5"	ID-OD	8"-8"	10"
10317	—	5"	ID-OD	12"-12"	8"
10731	—	5"	ID-OD	12"-12"	10"
10732	—	5"	ID-OD	15"-15"	8"

Both ends are O.D.

P/N ALUMINIZED	P/N CHROME	DIAMETER	STYLE	LENGTH A-B	CENTERLINE RADIUS
10562	—	2 ½"	OD-OD	6"-6"	5"
10742	—	3"	OD-OD	4"-4"	3"
10564	—	3"	OD-OD	7"-7"	6"
10565	—	3 ½"	OD-OD	8"-8"	7"
10743	—	4"	OD-OD	6"-6"	6"
10566	—	4"	OD-OD	8"-8"	4 ½"
10745	—	4"	OD-OD	12"-12"	6"
10567	—	5"	OD-OD	8"-8"	5 ½"
10746	809752	5"	OD-OD	8"-8"	8"
10747	809753	5"	OD-OD	15"-15"	8"
10748	—	6"	OD-OD	7"-7"	10"

ELBOWS

ALUMINIZED 60° ELBOWS

One end is I.D., the other end is O.D.

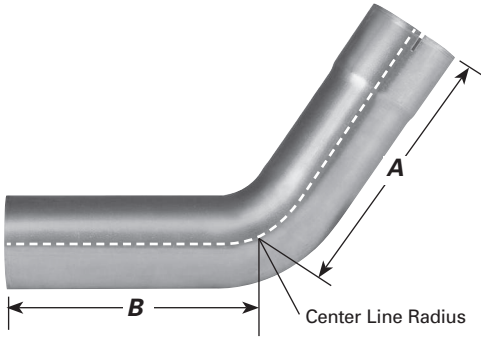

P/N	DIAMETER	STYLE	LENGTH A-B	CENTERLINE RADIUS
10639	3 1/2"	ID-OD	8"-8"	5"
10640	4"	ID-OD	8"-8"	5"
10641	5"	ID-OD	8"-8"	6"

Both ends are O.D.

P/N	DIAMETER	STYLE	LENGTH A-B	CENTERLINE RADIUS
10644	4"	OD-OD	8"-8"	5"
10645	5"	OD-OD	8"-8"	6"

ALUMINIZED & CHROME 67° ELBOWS

Both ends are O.D.

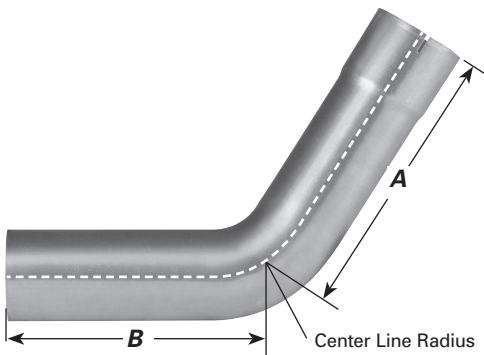

P/N ALUMINIZED	P/N CHROME	DIAMETER	STYLE	LENGTH A-B	CENTERLINE RADIUS
10560	809530	5"	OD-OD	7 1/2"-11"	8"

ELBOWS

ALUMINIZED & CHROME 90° ELBOWS

One end is I.D., the other end is O.D.

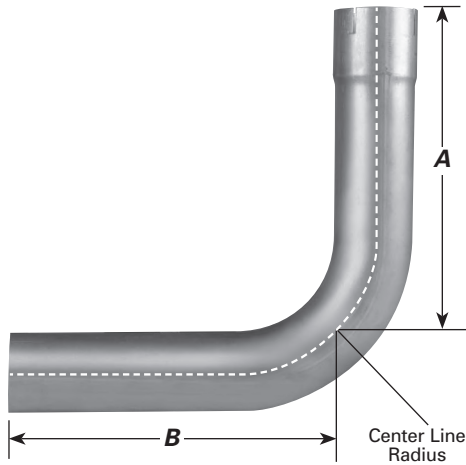

P/N ALUMINIZED	P/N CHROME	DIAMETER	LENGTH A-B	CENTERLINE RADIUS
10922	—	1½"	6½"-6½"	4"
10670	—	1¾"	6¼"-6¼"	4"
10301	—	2"	11"-11"	5"
10671	—	2"	6⅝"-6⅝"	4"
10673	—	2¼"	6⅝"-6⅝"	4½"
10302	—	2¼"	10⅞"-10⅞"	5"
10672	—	2½"	6⅝"-6⅝"	4½"
10303	—	2½"	12"-12"	5"
10674	—	2¾"	6⅝"-6⅝"	5"
10675	—	3"	8"-8¼"	6"
10756	—	3"	8½"-8½"	5"
10757	—	3"	10"-12"	5"
10758	—	3"	12"-12"	5"
10304	—	3"	14"-14"	6"
10795	—	3½"	6¼"-6¼"	3½"
10759	—	3½"	9½"-9¾"	5"
10676	—	3½"	9"-9"	4½"
10305	—	3½"	16"-16"	7"
10681	—	4"	8"-8"	4½"
—	809621	4"	10"-10"	5"
10678	—	4"	10"-10"	4½"
10761	809770	4"	12"-12"	6"
10762	—	4"	16"-16"	8"
10306	809406	4"	18"-18"	8"
10764	—	5"	8½"-8½"	6"
10557	809771	5"	11"-11"	6"
10680	809547	5"	11"-11"	7½"
10765	—	5"	15"-15"	8"
10554	809546	5"	15"-15"	10"
10766	—	5"	16½"-16½"	10"
10308	809408	5"	18"-18"	10"
10556	—	6"	15"-15"	10"

ELBOWS

ALUMINIZED & CHROME 90° ELBOWS

Both ends are O.D.

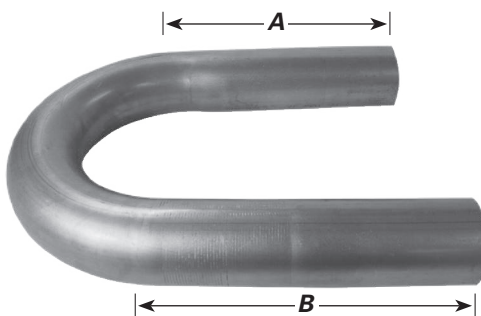
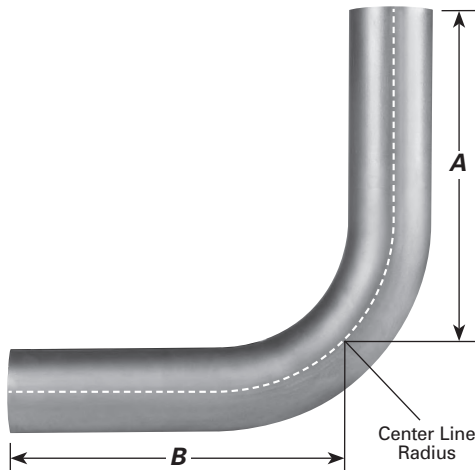

P/N ALUMINIZED	P/N CHROME	DIAMETER	LENGTH A-B	CENTERLINE RADIUS
10773	—	2"	9"-9"	5"
10774	—	2½"	12"-12"	5"
10337	—	3"	3"-3"	3½"
10776	—	3"	6"-6"	3"
10777	—	3"	7"-7"	3"
10534	—	3"	10"-10"	6"
10778	—	3"	14"-14"	8"
10794	—	3½"	6"-6"	3½"
10338	—	3½"	4"-4"	4"
10329	—	3½"	8"-8"	4"
10535	—	3½"	12"-12"	7"
10536	—	3½"	16"-16"	7"
10339	—	4"	4½"-4½"	4½"
10780	—	4"	7"-7"	5"
10781	—	4"	8"-8"	4"
10538	—	4"	9"-15"	4½"
10783	—	4"	10"-10"	6"
10539	—	4"	12"-12"	5½"
10797	—	4"	16"-16"	8"
10537	—	4"	18"-18"	8"
10340	—	5"	5½"-5½"	5½"
10784	—	5"	7½"-7½"	6"
10785	809795	5"	8½"-8½"	6"
10786	—	5"	9"-11½"	5½"
10787	—	5"	8½"-12½"	6"
10788	—	5"	8¾"-14¼"	5½"
10789	—	5"	9½"-9½"	6"
10541	—	5"	11"-16"	5½"
10791	—	5"	12"-12"	6"
—	809796	5"	12"-12"	8"
10796	—	5"	15"-15"	5½"
10540	—	5"	15"-15"	8"
10309	—	5"	20"-20"	8"

ALUMINIZED 180° Mandrel U-Bends

Both ends are O.D.

P/N ALUMINIZED	P/N CHROME	DIAMETER	LENGTH A-B	CENTERLINE RADIUS
U21208	—	2½"	8"-8"	4½"
U30008	—	3"	8"-8"	5½"

REDUCERS



ALUMINIZED OD - ID REDUCER

Reduces larger I.D. pipe to smaller O.D. pipe.

P/N	OD - ID	LENGTH
8663	1 5/8" - 1 1/2"	4"
8661	1 7/8" - 1 3/4"	4 1/2"
8650	2" - 1 1/2"	4 1/2"
8651	2" - 1 5/8"	4"
8902	2" - 1 3/4"	5 3/4"
8652	2" - 1 7/8"	5 1/8"
8653	2 1/4" - 1 3/4"	5"
8938	2 1/4" - 2"	4"
8941	2 1/2" - 2"	4"
8654	2 1/2" - 2"	9 1/2"
8942	2 1/2" - 2 1/4"	4"
8655	2 1/2" - 2 1/4"	9 1/2"
9600	3" - 2 1/2"	6 1/4"
9334	3" - 2 3/4"	6"
9333	3 1/2" - 3"	6"
9722	4" - 3"	6"
9332	4" - 3 1/2"	6"
9331	5" - 4"	6"
9723	5" - 4 1/2"	6"
8969	6" - 5"	6"



ALUMINIZED ID - ID REDUCER

Reduces O.D. pipes of different sizes.

P/N	ID - ID	LENGTH
8921	1 1/4" - 1 1/2"	4"
8920	1 5/8" - 1 1/2"	4"
8922	2" - 1 1/2"	4"
8923	2" - 1 5/8"	4"
8944	2" - 1 3/4"	4 1/2"
8945	2" - 1 7/8"	4 1/2"
8924	2 1/8" - 2"	4"
8946	2 1/4" - 2"	4 1/2"
8947	2 1/2" - 2"	4 1/2"
8948	2 1/2" - 2 1/4"	4 1/2"
8952	2 3/4" - 2 1/2"	6"
8953	3" - 2 1/2"	6"
8954	3" - 2 3/4"	6"
8955	3 1/2" - 3"	6"
8956	4" - 3"	6"
8957	4" - 3 1/2"	8"
8958	5" - 4"	8"
9721	5" - 4 1/2"	6"
9335	6" - 5"	8"



ALUMINIZED ID - OD REDUCER

Reduces larger O.D. pipe to smaller I.D. pipe.

P/N	ID - OD	LENGTH
8925	1 1/2" - 1 3/8"	4"
8926	1 5/8" - 1 1/2"	4"
8927	1 3/4" - 1 1/2"	4"
8928	1 3/4" - 1 5/8"	4"
8929	1 7/8" - 1 1/2"	4"
8935	1 7/8" - 1 3/4"	4 1/2"
8936	2" - 1 3/4"	4 1/2"
8930	2" - 1 13/16"	4"
8660	2" - 1 7/8"	4"
8909	2 1/8" - 2"	5 3/4"
8931	2 1/4" - 1 7/8"	4"
8911	2 1/4" - 2"	5 3/4"
8932	2 1/4" - 2 1/8"	4"
8913	2 1/2" - 2"	5 3/4"
8940	2 1/2" - 2 1/4"	4 1/2"
8959	2 3/4" - 2 1/2"	6"
8960	3" - 2 1/2"	6"
8961	3" - 2 3/4"	6"
8962	3 1/2" - 3"	6"
8963	4" - 3"	6"
8964	4" - 3 1/2"	6"
8965	5" - 4"	6"
9336	6" - 5"	6"



ALUMINIZED OD - OD REDUCER

Reduces larger O.D. pipe to smaller I.D. pipe.

P/N	OD - OD	LENGTH
8904	2" - 1 13/16"	5 3/4"
8908	2 1/8" - 2"	7 1/4"
8657	2 1/4" - 2"	4"
8912	2 1/4" - 2"	5 3/4"
8658	2 1/2" - 2"	9 1/2"
8659	2 1/2" - 2 1/4"	9 1/2"
9648	4" - 3"	8"
9649	5" - 4"	8"
9720	6" - 4"	8"
9650	6" - 5"	8"

ACCESSORIES

ACCESSORIES

REDUCER BUSHINGS



ALUMINIZED SPLIT REDUCER BUSHINGS

Reduces I.D. of a muffler by $\frac{1}{8}$ " without increasing its overall length. Made of 16 gauge steel.

P/N	REDUCES FROM - TO
1A	3" - 2 $\frac{7}{8}$ "
2	2 $\frac{3}{4}$ " - 2 $\frac{5}{8}$ "
3	2 $\frac{5}{8}$ " - 2 $\frac{1}{2}$ "
5	2 $\frac{1}{2}$ " - 2 $\frac{3}{8}$ "
6	2 $\frac{3}{8}$ " - 2 $\frac{1}{4}$ "
7	2 $\frac{1}{4}$ " - 2 $\frac{1}{8}$ "

P/N	REDUCES FROM - TO
8	2 $\frac{1}{8}$ " - 2"
9	2" - 1 $\frac{7}{8}$ "
10	1 $\frac{7}{8}$ " - 1 $\frac{3}{4}$ "
11	1 $\frac{3}{4}$ " - 1 $\frac{5}{8}$ "
12	1 $\frac{5}{8}$ " - 1 $\frac{1}{2}$ "

CONNECTORS



ALUMINIZED ID - ID CONNECTOR

Connects O.D. pipes of the same size.

P/N	ID - ID	LENGTH
8916	1 $\frac{1}{2}$ " - 1 $\frac{1}{2}$ "	4"
23075	1 $\frac{1}{2}$ " - 1 $\frac{1}{2}$ "	18"
8949	1 $\frac{3}{4}$ " - 1 $\frac{3}{4}$ "	4 $\frac{1}{2}$ "
23076	1 $\frac{3}{4}$ " - 1 $\frac{3}{4}$ "	18"
8917	1 $\frac{7}{8}$ " - 1 $\frac{7}{8}$ "	4"
23077	1 $\frac{7}{8}$ " - 1 $\frac{7}{8}$ "	18"
14337	2" - 2"	4"
23078	2" - 2"	18"
8950	2 $\frac{1}{8}$ " - 2 $\frac{1}{8}$ "	4 $\frac{1}{2}$ "
8951	2 $\frac{1}{4}$ " - 2 $\frac{1}{4}$ "	4 $\frac{1}{2}$ "
23079	2 $\frac{1}{4}$ " - 2 $\frac{1}{4}$ "	18"
14338	2 $\frac{1}{2}$ " - 2 $\frac{1}{2}$ "	4"
23080	2 $\frac{1}{2}$ " - 2 $\frac{1}{2}$ "	18"
8980	2 $\frac{3}{4}$ " - 2 $\frac{3}{4}$ "	4"
13025	2 $\frac{3}{4}$ " - 2 $\frac{3}{4}$ "	12"
14339	3" - 3"	4"
14601	3" - 3"	6"
13026	3" - 3"	12"
14340	3 $\frac{1}{2}$ " - 3 $\frac{1}{2}$ "	4"
14602	3 $\frac{1}{2}$ " - 3 $\frac{1}{2}$ "	6"
13027	3 $\frac{1}{2}$ " - 3 $\frac{1}{2}$ "	12"
14341	4" - 4"	4"
14603	4" - 4"	6"
13028	4" - 4"	12"
14605	5" - 5"	6"
8974	6" - 6"	6"



ALUMINIZED ID - OD CONNECTOR

Connects I.D. and O.D. pipes of the same size.

P/N	ID - OD	LENGTH
8662	1 $\frac{1}{2}$ " - 1 $\frac{1}{2}$ "	4 $\frac{7}{8}$ "
13001	1 $\frac{1}{2}$ " - 1 $\frac{1}{2}$ "	12"
23001	1 $\frac{1}{2}$ " - 1 $\frac{1}{2}$ "	18"
23051	1 $\frac{1}{2}$ " - 1 $\frac{1}{2}$ "	24"
33001	1 $\frac{1}{2}$ " - 1 $\frac{1}{2}$ "	36"
13002	1 $\frac{5}{8}$ " - 1 $\frac{5}{8}$ "	12"
23002	1 $\frac{5}{8}$ " - 1 $\frac{5}{8}$ "	18"
8934	1 $\frac{3}{4}$ " - 1 $\frac{3}{4}$ "	4 $\frac{1}{2}$ "
13003	1 $\frac{3}{4}$ " - 1 $\frac{3}{4}$ "	12"
23003	1 $\frac{3}{4}$ " - 1 $\frac{3}{4}$ "	18"
23052	1 $\frac{3}{4}$ " - 1 $\frac{3}{4}$ "	24"
33002	1 $\frac{3}{4}$ " - 1 $\frac{3}{4}$ "	36"
8937	1 $\frac{7}{8}$ " - 1 $\frac{7}{8}$ "	4 $\frac{1}{2}$ "
13004	1 $\frac{7}{8}$ " - 1 $\frac{7}{8}$ "	12"
23004	1 $\frac{7}{8}$ " - 1 $\frac{7}{8}$ "	18"
23053	1 $\frac{7}{8}$ " - 1 $\frac{7}{8}$ "	24"
33003	1 $\frac{7}{8}$ " - 1 $\frac{7}{8}$ "	36"
8933	2" - 2"	5 $\frac{3}{4}$ "
8906	2" - 2"	7 $\frac{1}{4}$ "
13005	2" - 2"	12"
23005	2" - 2"	18"
23054	2" - 2"	24"
33004	2" - 2"	36"
8914	2 $\frac{1}{8}$ " - 2 $\frac{1}{8}$ "	4"
13006	2 $\frac{1}{8}$ " - 2 $\frac{1}{8}$ "	12"
23006	2 $\frac{1}{8}$ " - 2 $\frac{1}{8}$ "	18"
23055	2 $\frac{1}{8}$ " - 2 $\frac{1}{8}$ "	24"
33005	2 $\frac{1}{8}$ " - 2 $\frac{1}{8}$ "	36"

P/N	ID - OD	LENGTH
8939	2 $\frac{1}{4}$ " - 2 $\frac{1}{4}$ "	4 $\frac{1}{2}$ "
8915	2 $\frac{1}{4}$ " - 2 $\frac{1}{4}$ "	9 $\frac{1}{2}$ "
13007	2 $\frac{1}{4}$ " - 2 $\frac{1}{4}$ "	12"
23007	2 $\frac{1}{4}$ " - 2 $\frac{1}{4}$ "	18"
23056	2 $\frac{1}{4}$ " - 2 $\frac{1}{4}$ "	24"
33006	2 $\frac{1}{4}$ " - 2 $\frac{1}{4}$ "	36"
8943	2 $\frac{1}{2}$ " - 2 $\frac{1}{2}$ "	4 $\frac{1}{2}$ "
13008	2 $\frac{1}{2}$ " - 2 $\frac{1}{2}$ "	12"
23008	2 $\frac{1}{2}$ " - 2 $\frac{1}{2}$ "	18"
23057	2 $\frac{1}{2}$ " - 2 $\frac{1}{2}$ "	24"
33007	2 $\frac{1}{2}$ " - 2 $\frac{1}{2}$ "	36"
8975	3" - 3"	6"
13009	3" - 3"	12"
23009	3" - 3"	18"
23058	3" - 3"	24"
33008	3" - 3"	36"
8976	3 $\frac{1}{2}$ " - 3 $\frac{1}{2}$ "	6"
13010	3 $\frac{1}{2}$ " - 3 $\frac{1}{2}$ "	12"
9599	3 $\frac{1}{2}$ " - 3 $\frac{1}{2}$ "	18"
8991	4" - 4"	6"
13011	4" - 4"	12"
23010	4" - 4"	18"
23059	4" - 4"	24"
8978	5" - 5"	6"
13012	5" - 5"	12"
24712	5" - 5"	18"
23060	5" - 5"	24"
8979	6" - 6"	6"

CONNECTORS

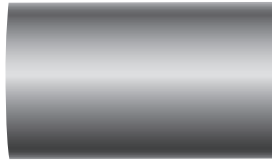

ALUMINIZED OD - OD CONNECTOR

Connects I.D. pipes of the same size.

P/N	OD - OD	LENGTH
8907	2" - 2"	5 ¾"
8918	2 ¼" - 2 ¼"	6"
8919	2 ½" - 2 ½"	4 ½"
8970	3" - 3"	6"
8971	3 ½" - 3 ½"	6"
8972	4" - 4"	8"
8973	5" - 5"	8"

FLARED ADAPTERS

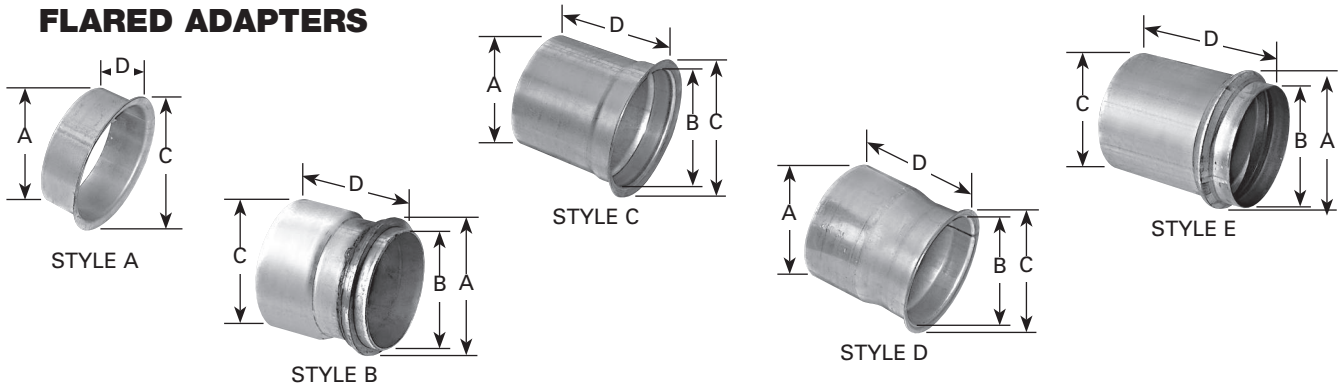

P/N	STYLE	A (O.D.)	B (I.D.)	C (O.D.)	D (LGTH.)	FLARE IN DEG.	APPLICATION	USE W/ V-BAND CLAMP
9706	D	3.977	2.836	3.970	3.482	20		9398
9707	A	2.500	3.345	3.695	1.532	20		9395
9390	A	NA	NA	NA	NA	20	FORD MOTOR CO, DETROIT DIESEL 6V71, 7V73, CUMMINS V555, V902	NA
9470	C	3.005	3.028	3.618	4.181	22	DETROIT DIESEL 6V71	9395
9708	A	3.005	2.869	3.541	3.568	45		NA
9471	C	3.005	3.040	3.775	4.522	45		9395
9479	A	3.183	3.015	3.915	2.200	20	GMC TRUCK/BUS W/ 8.2N	9611
9709	A	3.512	3.385	4.071	4.176	22	CAT 3208T	9611
9710	A	3.350	3.373	4.025	5.018	45	DETROIT DIESEL 6V71	9622
9392	C	3.525	3.505	4.320	6.095	45		9396
9473	C	3.490	3.630	4.165	4.035	22	DETROIT DIESEL 8V-71	9613
9711	C	3.520	3.620	4.270	4.100	22	DETROIT DIESEL 8V-72	9396
9712	C	3.480	3.670	4.212	4.140	22	DETROIT DIESEL 8V-73	9613
9391	A	3.010	2.865	3.905	1.310	20	DETROIT DIESEL 8V92, 4-53	9611
9713	D	3.990	3.605	4.260	4.050	22	DETROIT DIESEL 8V-71	9613
9476	C	NA	NA	NA	NA	22	DETROIT DIESEL 12V71	NA
9472	D	3.960	3.550	4.305	3.868	22	DETROIT DIESEL 8.2N, CUMMINS VT225	9396
9714	C	4.005	3.975	4.500	5.922	45		NA
9474	A	3.950	3.850	4.535	1.810	22	DETROIT DIESEL 6-71, 8.2N, 8.2T, MACK	NA
9475	A	3.985	3.875	4.540	5.170	45	CUMMINS	NA
♣9715	B	5.13	4.250	4.800	1.940	20	DETROIT DIESEL 8V-71T, 16V-71T, 6V-92T, 8V-92T	NA
9393	A	5.005	4.880	5.475	6.275	45	CUMMINS	NA
9478	A	5.035	4.870	5.720	3.025	22	CATERPILLAR TURBO, CUMMINS TURBO, INTERNATIONAL	9616
9716	A	4.990	4.825	5.572	5.608	20	INTERNATIONAL	NA
9717	A	5.010	4.885	5.845	6.287	20	T-50 TURBO CHARGER	9616
9394	C	NA	NA	NA	NA	45	T-50 TURBO CHARGER	NA
9719	E	5.658	4.825	4.998	6.168	NA	CUMMINS ENGINES	9615

♣ WITH MACHINED RING

ACCESSORIES

ACCESSORIES

FLEX COUPLING

FEATURES	(VALUE)	(PREMIUM)
	200 STAINLESS	300 STAINLESS
2 Ply Bellows for Max Strength	✓	✓
Seamless Convolutd Inner core to prevent leaks	✓	✓
Reduces Vibration Stress Fatigue	✓	✓
Inner Braid Option Adds Longer Life	✓	✓
Large 3" Diameter for Heavy Duty & Perf. Applications		✓
Longest Life for Maximum Corrosion Protection		✓
Highest Temperature Resistance to Fatigue		✓

WITHOUT NIPPLE EXTENSION

	200 SERIES W/ INNER BRAID	300 SERIES W/O INNER BRAID	300 SERIES W/ INNER BRAID	INLET DIAMETER	OVERALL LENGTH	FLEX LENGTH
FT13404B	8810	8810IB	1.77"	4"	4"	
FT13406B	8811	8811IB	1.77"	6"	6"	
FT13408B	8812	8812IB	1.77"	8"	8"	
FT13410B	8813	8813IB	1.77"	10"	10"	
FT20004B	8814	8814IB	2.02"	4"	4"	
FT20006B	8815	8815IB	2.02"	6"	6"	
FT20008B	8816	8816IB	2.02"	8"	8"	
FT20010B	8817	8817IB	2.02"	10"	10"	
FT22504B	8818	8818IB	2.27"	4"	4"	
FT22506B	8819	8819IB	2.27"	6"	6"	
FT22508B	8820	8820IB	2.27"	8"	8"	
FT22510B	8821	8821IB	2.27"	10"	10"	
FT25004B	8822	8822IB	2.52"	4"	4"	
FT25006B	8823	8823IB	2.52"	6"	6"	
FT25008B	8824	8824IB	2.52"	8"	8"	
FT25010B	8825	8825IB	2.52"	10"	10"	
—	8826	8826IB	3.02"	4"	4"	
—	8827	8827IB	3.02"	6"	6"	
—	8828	8828IB	3.02"	8"	8"	
—	8829	8829IB	3.02"	10"	10"	
—	—	8831IB	3.52"	8"	8"	

- ✓ Complete Coverage
- ✓ Available with or without Expandable Nipple Extensions
- ✓ Available with Inner Braid

WITH NIPPLE EXTENSION

FT13404N	8835	8835IB	1.75"	8"	4"
FT13406N	8836	8836IB	1.75"	10"	6"
FT13408N	8837	8837IB	1.75"	12"	8"
FT13410N	8838	8838IB	1.75"	14"	10"
FT20004N	8839	8839IB	2.00"	8"	4"
FT20006N	8840	8840IB	2.00"	10"	6"
FT20008N	8841	8841IB	2.00"	12"	8"
FT20010N	8842	8842IB	2.00"	14"	10"
FT22504N	8843	8843IB	2.25"	8"	4"
FT22506N	8844	8844IB	2.25"	10"	6"
FT22508N	8845	8845IB	2.25"	12"	8"
FT22510N	8846	8846IB	2.25"	14"	10"
FT25004N	8847	8847IB	2.50"	8"	4"
FT25006N	8848	8848IB	2.50"	10"	6"
FT25008N	8849	8849IB	2.50"	12"	8"
FT25010N	8850	8850IB	2.50"	14"	10"
—	8851	8851IB	3.00"	8"	4"
—	8852	8852IB	3.00"	10"	6"
—	8853	8853IB	3.00"	12"	8"
—	8854	8854IB	3.00"	14"	10"



Y-PIPES & TUBING

CONVENTIONAL "Y" PIPE

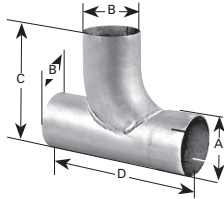

P/N	A	B	C	D
92698	4" ID	3" OD	8½"	14"
92678	4" ID	3½" OD	11"	15"
92679	4" ID	4" OD	9"	14"
92689	5" ID	5" OD	10½"	15"

SPLITTER "T" ADAPTER PIPE

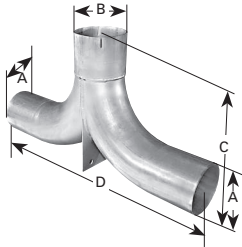

P/N WITHOUT BRACKET	P/N WITH BRACKET	A	B	C	D
92695	—	4" OD	4" ID	12"	20"
—	92673	4" OD	4" ID	11¼"	16"
—	92674	5" OD	5" ID	14"	25"
92696	—	5" OD	5" OD	11"	19"
92697	—	5" OD	5" ID	13½"	22"

UNIVERSAL ALUMINIZED Y-PIPES

UNIVERSAL ALUMINIZED Y-PIPES

P/N	INLET SIZE	OUTLET SIZE	OVERALL SIZE
AVY225	2 ¼" I.D.	2 ¼" O.D.	12"
AVY250	2 ½" I.D.	2 ½" O.D.	12"

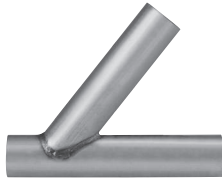

UNIVERSAL ALUMINIZED Y-PIPES

P/N	INLET SIZE	OUTLET SIZE	OVERALL SIZE
AY175	1 ¾" I.D.	1 ¾" O.D.	12 ½"
AY200	2" I.D.	2" O.D.	12 ½"
AY225	2 ¼" I.D.	2 ¼" O.D.	12 ½"
AY250	2 ½" I.D.	2 ½" O.D.	13"
AY300	3" I.D.	2 ½" O.D.	13"



UNIVERSAL ALUMINIZED STEEL Y-PIPES

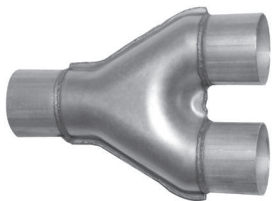

UNIVERSAL ALUMINIZED STEEL Y-PIPE

P/N	INLET SIZE	OUTLET SIZE	OVERALL SIZE
AYS250	2 ½" I.D.	2 ½" I.D.	10"



UNIVERSAL ALUMINIZED STEEL X-PIPE

P/N	INLET SIZE	OUTLET SIZE	OVERALL SIZE
AXS250	2 ½" I.D.	2 ½" I.D.	12"

ACCESSORIES

FLANGES & GASKETS

CONVERSION FLANGE AND TUBE



9524 Tube
9569 Flange (Sold Separately)



9586

P/N	SIZE	DESCRIPTION
9524	3"	TUBE
9569	3"	FLANGE
9586	4"	FLANGE 4" NH CUMMINS

SINGLE PIECE INSERTS WITH GASKET



8699

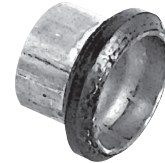

9259

P/N	DESCRIPTION
9260	CHEVROLET/GMC MED TRUCK/BUS w/ 366, 427 ENG.
8699	INTERNATIONAL MED TRUCK/BUS w/ V304, V345 ENG.
9259	CHEVROLET/GMC MED TRUCK BUS w/ 350 ENG.

FLEXIBLE TUBING

PRE-CUT FLEX HOSE STYLE ID-ID

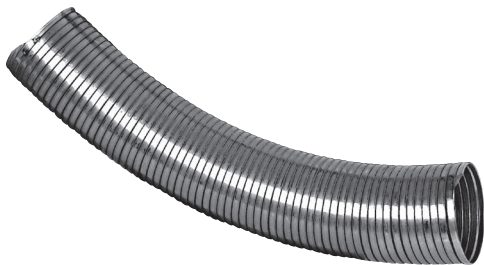

P/N STAINLESS	P/N ALUMINIZED	P/N GALVANIZED	LGTH.
3" DIA			
24675	—	24752	18"
—	—	24930	24"
—	—	34826	36"
3 1/2" DIA			
24676	—	24753	18"
—	—	24849	24"
—	—	34785	36"
4" DIA			
14739	—	14738	12"
24677	24931	24754	18"
24836	—	24835	24"
34673	—	34743	36"
—	—	44786	48"
64791	—	64793	72"
5" DIA			
14737	—	14740	12"
24678	24933	24755	18"
24838	—	24837	24"
34674	—	34744	36"
44867	—	54831	48"
64792	—	64794	72"

PRE-CUT FLEX HOSE STYLE ID-OD



P/N STAINLESS	P/N GALVANIZED	LGTH.
3" DIA		
—	24674	18"
3 1/2" DIA		
—	24935	18"
4" DIA		
—	24654	18"
5" DIA		
—	24936	18"

STAINLESS STEEL BELLOWS PIPE



P/N	DIA	LGTH.
9726	3"	12"
9727	3 1/2"	12"
9728	4"	12"
9729	5"	12"

FLEXIBLE TUBING

PROCEDURE FOR CUTTING FLEXIBLE TUBING

NOTE: Flexible tubing coils are in a contracted state. Before cutting, anchor one end and pull and/or snap the coil to bring it back to its proper length.

HACKSAW: (For less frequent cutting)

WIDTH: ½" or ¾"

TEETH: A no set blade is preferred, although it is usually hard to find locally - 14 tooth or finer.

BANDSAW: (For less frequent cutting)

WIDTH: ½" or ¾"

TEETH: A no set blade - 14 tooth, run at 350 feet per minute.

A bi-metal blade gives more cuts per dollar than an ordinary carbon steel blade. Lenox seems to be the best blade for our applications.



FLEX TUBING 10 FOOT LENGTHS

P/N STAINLESS STANDARD THICKNESS	P/N ALUMINIZED HEAVY DUTY THICKNESS	P/N GALVANIZED HEAVY DUTY THICKNESS	ID
8883	—	8984	2"
8855	—	—	2 ¼"
8884	8858	8985	2 ½"
8885	8859	8986	3"
8886	8876	8987	3 ½"
8887	8856	8988	4"
8888	8857	8989	5"
8895	—	8990	6"
—	—	8893	8"
—	—	8894	10"

FLEX TUBING 25 FOOT LENGTHS

P/N STAINLESS STANDARD THICKNESS	P/N GALVANIZED STANDARD THICKNESS	P/N GALVANIZED HEAVY DUTY THICKNESS	ID
—	8860	—	1"
—	8861	—	1 ⅛"
—	8862	—	1 ¼"
—	8863	—	1 ⅜"
—	8864	—	1 ½"
—	8865	—	1 ⅝"
—	8866	—	1 ¾"
—	8867	—	1 ⅞"
—	8868	—	2"
—	8869	—	2 ⅛"
—	8870	—	2 ¼"
—	8872	—	2 ½"
8982	8875	8880	3"
8983	—	8881	3 ½"
8878	—	8882	4"
8879	—	8877	5"
8899	—	8898	6"

ACCESSORIES

STRAIGHT TUBING ALUMINIZED

- Manufactured from Aluminum Killed Deep Drawing Quality Steel - Prevents Splits and Wrinkles
- Re-aluminized Weld Seam - Better Appearance and Helps Prevent Corrosion
- All the Necessary Diameters, Lengths and Gauges For Your Bending Needs

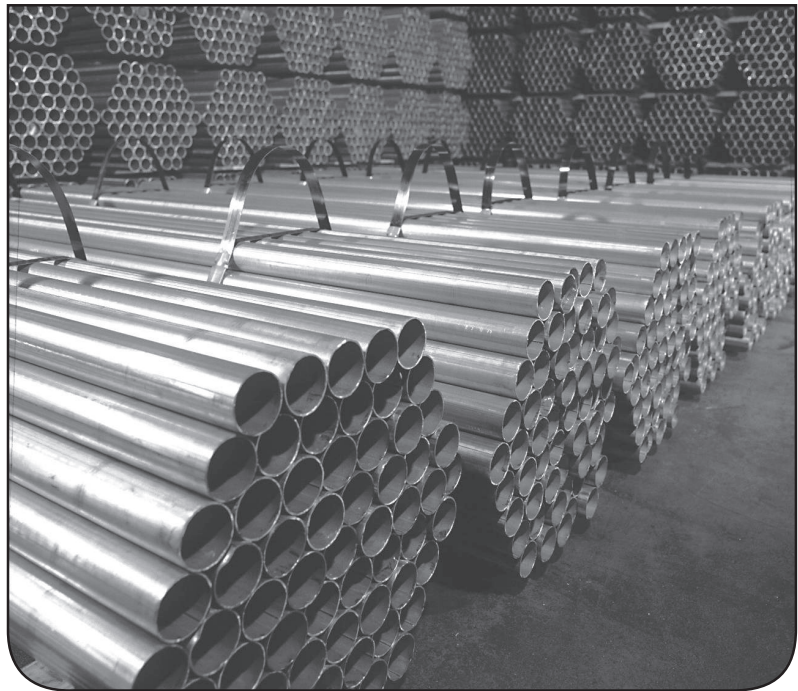

STRAIGHT TUBING

PART NO.	O.D.	GAUGE	LENGTH
BENDABLE ALUMINIZED TUBING			
112A1016	1 1/2"	16	10'
112A7516	1 1/2"	16	7.5'
134A1016	1 3/4"	16	10'
134A7516	1 3/4"	16	7.5'
178A1016	1 7/8"	16	10'
200A1014	2"	14	10'
200A1016	2"	16	10'
200A7514	2"	14	7.5'
200A7516	2"	16	7.5'
212A1014	2 1/2"	14	10'
212A7514	2 1/2"	14	7.5'
214A1014	2 1/4"	14	10'
214A7514	2 1/4"	14	7.5'
234A1014	2 3/4"	14	10'
300A1014	3"	14	10'
300A7514	3"	14	7.5'
300A1013	3"	13	10'
300A7513	3"	13	7.5'
312A1014	3 1/2"	14	10'
312A1016	3 1/2"	16	10'
312A7516	3 1/2"	16	7.5'
400A1014	4"	14	10'
400A1016	4"	16	10'
400A7516	4"	16	7.5'
400A1414	4"	14	14'
500A1016	5"	16	10'
600A1016	6"	16	10'
800A1016	8"	16	10'

PART NO.	O.D.	GAUGE	LENGTH
BENDABLE ALUMINIZED TUBING			
I.D. SCARFED NO STAMPING ON TUBING			
200A1016SN	2"	16	10'
200A1014SN	2"	14	10'
214A1016SN	2 1/4"	16	10'
214A1014SN	2 1/4"	14	10'
212A1016SN	2 1/2"	16	10'
212A1014SN	2 1/2"	14	10'
300A1016SN	3"	16	10'
300A1014SN	3"	14	10'

PART NO.	O.D.	GAUGE	LENGTH
BENDABLE 409 STAINLESS TUBING			
200S1016	2"	16	10'
214S1014	2 1/4"	14	10'
212S1014	2 1/2"	14	10'
300S1014	3"	14	10'

PART NO.	O.D.	GAUGE	LENGTH
304 STAINLESS STEEL TUBING			
(NON-BENDABLE)			
312S1016	3 1/2"	16	10'
400S1016	4"	16	10'

PART NO.	SIZE	LENGTH
ALUMINIZED STEEL TUBING		
(ONE END SWAGED & SLOTTED, OTHER END-O.D.)		
923120	3"	10'
924120	4"	10'
925120	5"	10'

ACCESSORIES

CHROME TIPS

CHEVELLE TIPS



P/N	INLET SIZE	OVERALL SIZE
XWT200	2" I.D.	1 3/4" x 3 3/4"
XWT214	2 1/4" I.D.	1 3/4" x 3 3/4"
XCT410	2 1/2" I.D.	1 3/4" x 4"

DUAL TRANS AM TIPS



P/N	INLET SIZE	OVERALL SIZE
XDT214	2 1/4" I.D.	12" x 2 1/2"

INSIDE ROLL PENCIL TIPS

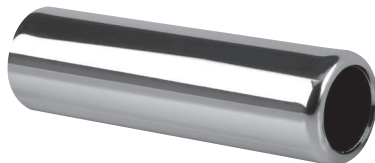

P/N	INLET SIZE	OVERALL SIZE
XRPT134	1 3/4" I.D.	8" x 2 1/2"
XRPT200	2" I.D.	9" x 2 1/4"
XRPT214	2 1/4" I.D.	9" x 2 1/2"
XRPT212	2 1/2" I.D.	9" x 2 3/4"
XRPT3506	2 1/4" I.D.	6" x 3 1/2"
XRPT4006	2 1/2" I.D.	6" x 4"
XRPT4012	2 1/2" I.D.	12" x 4"
XRPT4018	2 1/2" I.D.	18" x 4"
XRPT3512	2 1/4" I.D.	12" x 3 1/2"
XRPT35123	3" I.D.	12" x 3 1/2"

DUAL PENCIL TIPS



P/N	INLET SIZE	OVERALL SIZE
XDP200	2" I.D.	11" x 5 1/2" (outlet 2 1/4")

DUAL ANGLE CUT TIPS



P/N	INLET SIZE	OVERALL SIZE
XDA200	2" I.D.	11" x 5 1/2" (outlet 2 1/4")

INSIDE ROLL ANGLE CUT TIPS



P/N	INLET SIZE	OVERALL SIZE
XRAC312	2" I.D.	12" x 3"
XRAC316	2" I.D.	16" x 3"
XRAC31212	2 1/4" I.D.	12" x 3 1/2"
XRAC312123	3" I.D.	12" x 3 1/2"
XRAC31216	2 1/4" I.D.	16" x 3 1/2"
XRAC31218	2 1/4" I.D.	18" x 3 1/2"
XRAC31222	2 1/4" I.D.	22" x 3 1/2"
XRAC412	2 1/2" I.D.	12" x 4"
XRAC418	2 1/2" I.D.	18" x 4"
XRAC422	2 1/2" I.D.	22" x 4"

ACCESSORIES

CHROME TIPS

TURN DOWN TIPS



P/N	INLET SIZE	OVERALL SIZE
XTD112	1 ½" I.D.	8" x 1 ¾"
XTD134	1 ¾" I.D.	8" x 2"
XTD200	2" I.D.	9" x 2 ¼"
XTD214	2 ¼" I.D.	11" x 2 ½"
XTD212	2 ½" I.D.	13" x 2 ½"

PENCIL TIPS

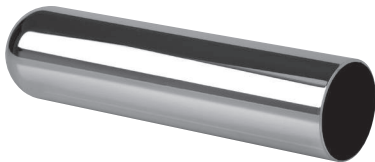

P/N	INLET SIZE	OVERALL SIZE
XPT112	1 ½" I.D.	8" x 1 ¾"
XPT134	1 ¾" I.D.	8" x 2"
XPT200	2" I.D.	9" x 2 ¼"
XPT214	2 ¼" I.D.	9" x 2 ½"
XPT212	2 ½" I.D.	9" x 2 ¾"
XPT312	2" I.D.	12" x 3"
XPT31212	2 ¼" I.D.	12" x 3 ½"

SPECIALTY TURN DOWN TIP



P/N	INLET SIZE	LENGTH
9818	1 7/8" I.D.	11"

ANGLE CUT TIPS



P/N	INLET SIZE	OVERALL SIZE
XAC200	2" I.D.	9" x 2 ¼"
XAC214	2 ¼" I.D.	9" x 2 ½"
XAC212	2 ½" I.D.	9" x 2 ¾"
XAC312	2" I.D.	12" x 3"
XAC312214	2 ¼" I.D.	12" x 3"
XAC316	2" I.D.	16" x 3"
XAC316214	2 ¼" I.D.	16" x 3"
XAC324	2" I.D.	24" x 3"
XAC31212	2 ¼" I.D.	12" x 3 ½"
XAC31216	2 ¼" I.D.	16" x 3 ½"
XAC31218	2 ¼" I.D.	18" x 3 ½"
XAC31222	2 ¼" I.D.	22" x 3 ½"
XAC31222212	2 ½" I.D.	22" x 3 ½"
XAC412	2 ½" I.D.	12" x 4"
XAC418	2 ½" I.D.	18" x 4"
XAC4183	3" I.D.	18" x 4"
XAC422	2 ½" I.D.	22" x 4"
XAC518	2 ½" I.D.	18" x 5"

SPECIALTY CHROME TIPS - BOLT ON



P/N	INLET SIZE	LENGTH
9821	1 ½" I.D.	5 ¼"
9822	1 ¾" I.D.	5 ¼"
9817	1 7/8" I.D.	3 3/8"
9820	2" I.D.	5 ¼"
9819	2 ¼" I.D.	5 ¼"

STAINLESS TIPS

SPECIALTY TIPS



1



2



3



4



5

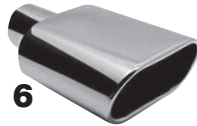

6



7

P/N	INLET SIZE	OVERALL SIZE	TYPE
SV7840	2 ½" I.D.	6" x 2" - OAL 10"	1
XSCAM212	2 ½" I.D.	7¾" x 2" - OAL 10"	1
XSSDW4128	2 ¼" I.D.	9" x 4 ½"	2
XSDW3002	2" I.D.	6 ¼" x 3"	3
XSRPT3507	2 ¼" I.D.	7" x 3 ½"	4
XSOR512	2 ½" I.D.	5 ¼" x 3 ¼" - OAL 7 ½"	5
XSRS600	2 ¼" I.D.	6" Oval - OAL 9"	6
SV7866	2 ½" I.D.	4" - OAL 7"	7

PENCIL TIPS



P/N	INLET SIZE	OVERALL SIZE
XSRPT200	2" I.D.	9" x 2 ¼"
XSRPT214	2 ¼" I.D.	9" x 2 ½"
XSRPT212	2 ½" I.D.	9" x 2 ¾"

CHEVY BOWTIE TIPS



P/N	INLET SIZE	OVERALL SIZE
XSCB214	2 ¼" I.D.	9" x 4 ¾"
XSCB212	2 ½" I.D.	9" x 4 ¾"
XSCB300	3" I.D.	9" x 4 ¾"

INSIDE ROLL ANGLE CUT TIPS



P/N	INLET SIZE	OVERALL SIZE
XSRAC316	2 ¼" I.D.	16" x 3"
XSRAC31212	2 ¼" I.D.	12" X 3 ½"
XSRAC31216	2 ¼" I.D.	16" x 3 ½"
XSRAC31218	2 ¼" I.D.	18" x 3 ½"
XSRAC31222	2 ½" I.D.	22" x 3 ½"
XSRAC418	2 ½" I.D.	18" x 4"
XSBRAC40124	4" Bolt On	12" x 4"
XSBRAC50124	4" Bolt On	12" x 5"
XSBRAC50125	5" Bolt On	12" x 5"
XSBRAC50184	4" Bolt On	18" x 5"
XSBRAC50185	5" Bolt On	18" x 5"
SV5012SR	4" No Bolt	12" x 5"

ACCESSORIES

STAINLESS TIPS

ANGLE CUT TIPS



P/N	INLET SIZE	OVERALL SIZE
XSAC214	2 ¼" I.D.	9" x 2 ½"
XSAC212	2 ½" I.D.	9" x 2 ¾"
XSAC312214	2 ¼" I.D.	12" x 3"
XSAC316	2" I.D.	16" x 3"
XSAC316214	2 ¼" I.D.	16" x 3"
XSAC318	2 ¼" I.D.	18" x 3"
XSAC318212	2 ½" I.D.	18" x 3"
XSAC31212	2 ¼" I.D.	12" x 3 ½"
XSAC31216	2 ¼" I.D.	16" x 3 ½"
XSAC31218	2 ¼" I.D.	18" X 3 ½"
XSAC31218212	2 ½" I.D.	18" x 3 ½"
XSAC31222	2 ¼" I.D.	22" x 3 ½"
XSAC31222212	2 ½" I.D.	22" x 3 ½"
XSAC412	2 ½" I.D.	12" x 4"
XSAC418	2 ½" I.D.	18" x 4"
XSAC616212	2 ½" I.D.	16" x 6"

TURN DOWN TIPS



P/N	INLET SIZE	OVERALL SIZE
XSTD300	3" I.D.	16" x 3"

O.E. FLARED DIFFUSER TIP



Freightliner O.E. #04-24971-000
Thomas O.E. #135779

P/N	DIA	LGTH.
24011	4" ID	14½"

STAINLESS TIPS

BOLT-ON / CLAMP-ON TIPS



ST1255S



ST1254S



ST1257S



ST1253S



ST1256S

P/N	INLET SIZE	OVERALL SIZE
ST1255S	2 ¼" I.D.	2" x 2 ¼"
ST1253S	2 ¼" I.D.	5 ½" x 3"
ST1257S	2 ¼" I.D.	7" x 3 ½"
ST1254S	2 ½" I.D.	7" x 3 ½"
ST1256S	2 ½" I.D.	10" x 3"

STAINLESS TIPS - OE REPLACEMENT STYLE (BOLT-ON, CLAMP-ON)

TOYOTA / LEXUS TIP



P/N	INLET SIZE	OVERALL SIZE	LENGTH
9850	w/ Mounting Saddle for 2" Pipe	2 ¾" x 3 7/16"	5 1/16"

HONDA/ACURA TIP - TAP ON



P/N	INLET SIZE	OVERALL SIZE
9816	For 1 ½" Pipe	5 ½" x 1 ½"

ACCESSORIES

ACCESSORIES

STAINLESS TIPS - OE REPLACEMENT STYLE (BOLT-ON, CLAMP-ON)

HYUNDAI TIPS



Hyundai, Santa Fe, LH
Hyundai, Veracruz, LH

P/N	INLET SIZE	OVERALL SIZE
ST1261S	2" I.D.	6¾" x 3" x 6"



Hyundai, Santa Fe, RH
Hyundai, Veracruz, RH

P/N	INLET SIZE	OVERALL SIZE
ST1262S	2" I.D.	6¾" x 3" x 6"

GMC TIP



GMC Acadia, LH & RH

P/N	INLET SIZE	OVERALL SIZE
ST1260S	2" I.D.	4½" x 3"

KIA/ACURA TIPS

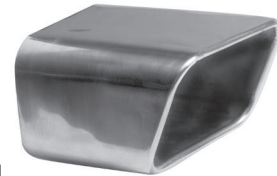

Kia Sportage, LH
Acura MDX, LH

P/N	INLET SIZE	OVERALL SIZE
ST1265S	2" I.D.	5½" x 3⅜" x 5¼"



Kia Sportage, RH
Acura MDX, RH

P/N	INLET SIZE	OVERALL SIZE
ST1266S	2" I.D.	5½" x 3⅜" x 5¼"

MAZDA/ACURA TIPS

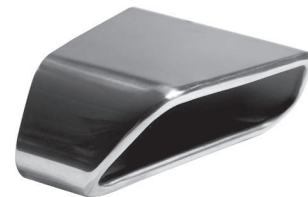

Mazda CX-9, LH
Acura TL, LH

P/N	INLET SIZE	OVERALL SIZE
ST1267S	2⅛" I.D.	5" x 3" x 7¼"



Mazda CX-9, RH
Acura TL, RH

P/N	INLET SIZE	OVERALL SIZE
ST1268S	2⅛" I.D.	5" x 3" x 7¼"

STAINLESS TIPS - OE REPLACEMENT STYLE (BOLT-ON, CLAMP-ON)

GM TIPS



Buick Enclave, LH

P/N	INLET SIZE	OVERALL SIZE
ST1263S	2 ³ / ₈ " I.D.	10" x 3" x 6"



Buick Enclave, RH

P/N	INLET SIZE	OVERALL SIZE
ST1264S	2 ³ / ₈ " I.D.	10" x 3" x 6"

FORD TIP



Ford Mustang GT

P/N	INLET SIZE	OVERALL SIZE
ST1269S	3" I.D.	5 ¹ / ₂ " x 3 ¹ / ₂ "

HYUNDAI TIP



Santa Fe Sport

P/N	INLET SIZE	OVERALL SIZE
ST1271S	2 ³ / ₁₀ " I.D.	3 ³ / ₄ " x 3"

SPOUTS

TAIL SPOUTS

Recommended for passenger cars and trucks not equipped with a tail pipe. Can also be used with tractor mufflers to deflect exhaust gases away from the operator. For horizontal or vertical mounting.



STYLE A

STYLE B

P/N ALUMINIZED STYLE A (OD)	P/N CHROME STYLE A (OD)	P/N ALUMINIZED STYLE B (ID)	P/N CHROME STYLE B (ID)	DIAM-ETER	LENGTH
10921	—	—	—	2"	8" NAT
14342	—	—	—	2 ¹ / ₄ "	12"
14343	—	—	—	2 ¹ / ₂ "	10"
14634	—	—	—	2 ³ / ₄ "	12"
24344	—	14618	814621	3"	12"
—	—	—	824000	3"	18"
24345	—	14619	814622	3 ¹ / ₂ "	12"
—	—	24938	824001	3 ¹ / ₂ "	18"
24346	—	14620	814620	4"	12"
24717	824720	24713	824718	4"	18"
24718	824723	24714	824717	5"	18"
24347	—	24672	824673	5"	20"
—	—	24696	—	6"	20"

NAT = No Angle Trim (outlet)

SILVERLINE TIPS WITH LOGO

STAINLESS TRUCK TIPS

45° SLASH CUT ANGLE TIPS WITH NECK

PART NO.	INLET ID	OUTLET DIAMETER	OVERALL LENGTH
TK3012S	2 1/4"	3"	12"
TK3018S	2 1/4"	3"	18"
TK3512S	2 1/4"	3 1/2"	12"
TK3518S	2 1/4"	3 1/2"	18"
TK3522S	2 1/4"	3 1/2"	22"
TK3518S25	2 1/2"	3 1/2"	18"
TK3522S25	2 1/2"	3 1/2"	22"
TK4012S	2 1/4"	4"	12"
TK4018S	2 1/4"	4"	18"
TK4018S25	2 1/2"	4"	18"



TK4018S

All Silverline TK Tips are Premium Quality T304 Polished Stainless and feature the Silverline™ Logo.

20° ANGLE ROLLED TIPS WITH NECK

PART NO.	INLET ID	OUTLET DIAMETER	OVERALL LENGTH
TK3012SR	2 1/4"	3"	12"
TK3018SR	2 1/4"	3"	18"
TK3512SR	2 1/4"	3 1/2"	12"
TK3518SR	2 1/4"	3 1/2"	18"
TK3512SR25	2 1/2"	3 1/2"	12"
TK3518SR25	2 1/2"	3 1/2"	18"
TK3522SR25	2 1/2"	3 1/2"	22"
TK4012SR	2 1/4"	4"	12"
TK4018SR	2 1/4"	4"	18"
TK4018SR25	2 1/2"	4"	18"



TK3512SR

All Silverline TK Tips are Premium Quality T304 Polished Stainless and feature the Silverline™ Logo.

SILVERLINE TIPS WITH LOGO

DIESEL TRUCK TIPS

ROLLED ANGLE TRUCK TIPS

PART NO.	INLET ID	OUTLET DIAMETER	OVERALL LENGTH
TK4012SR35	3 1/2"	4"	12" Without Bolt
TK5012SR	4"	5"	12" Without Bolt
TK5012SRB	4"	5"	12" With Bolt
TK5012SRB5	5"	5"	12" With Bolt
TK6018SRB	4"	6"	18" With Bolt
TK6018SRB5	5"	6"	18" With Bolt

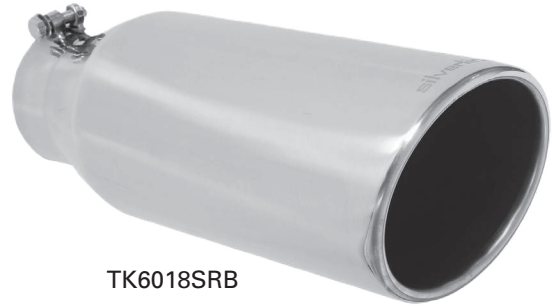

TK6018SRB

All Silverline TK Tips are Premium Quality T304 Polished Stainless and feature the Silverline™ Logo.

DOUBLE WALL TRUCK TIPS

PART NO.	INLET ID	OUTLET DIAMETER	OVERALL LENGTH
TK5012DWB	4"	5"	12" Pencil Cut with Bolt



All Silverline TK Tips are Premium Quality T304 Polished Stainless and feature the Silverline™ Logo.

TURN DOWN TRUCK TIPS





PART NO.	INLET ID	OUTLET DIAMETER	OVERALL LENGTH
TK5012TDB4	4"	5"	12" With Bolt



All Silverline TK Tips are Premium Quality T304 Polished Stainless and feature the Silverline™ Logo.

SILVERLINE TIPS WITH LOGO

SPECIALTY TIPS - T304 STAINLESS

	PART NO.	INLET ID	OUTLET	OVERALL LENGTH	STYLE
	TK7840	2 1/2"	6" x 2"	10"	Camaro "seamless"
	TK7850	2 1/2"	7 3/4" x 2"	10"	Camaro "seamless"
	TK7809	2 1/4"	3"	7"	Beveled Inner
	TK7819	2 1/4"	4 1/2" x 3"	7"	Oval Double Wall
	TK7855	2 1/4"	3" x 4"	7"	Oval Rolled

SILVERLINE

SILVERLINE TIPS WITH LOGO

SPECIALTY TIPS - T304 STAINLESS

PART NO.	INLET ID	OUTLET	OVERALL LENGTH	STYLE	
TK7864C	3"	3 1/2"	9 1/2"	Chrome Over, Angle	
TK7865C	2 1/2"	3 1/2"	5 1/2"	Chrome Over, Angle	
TK7867C	2 3/8"	4 1/2" x 3 1/2"	5 1/2"	Chrome Over, Oval	
TK7868C	2 1/2"	3 1/2"	16"	Chrome Over, Angle	
TK7869C	2 1/2"	3" x 2 1/2"	10"	Chrome Over, Dual Oval	
TK9001	2 1/2"	3"	4"	Chrome Over, Angle	
TK9002	2 1/2"	3"	9 3/4"	Chrome Over Offset Dual - Right	
TK9003	2 1/2"	3"	9 3/4"	Chrome Over Offset Dual - Left	
TK9004	2 1/2"	3"	9 3/4"	Chrome Over Angle Dual, Left or Right	

ACCESSORIES

TOOLS

CUT OFF WHEELS

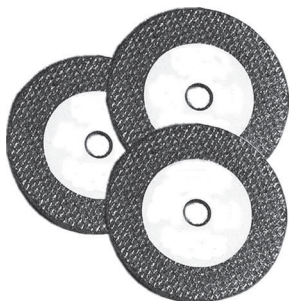

Part No. UP1150

(Three replacement cutting wheels)

PIPE HOOKS

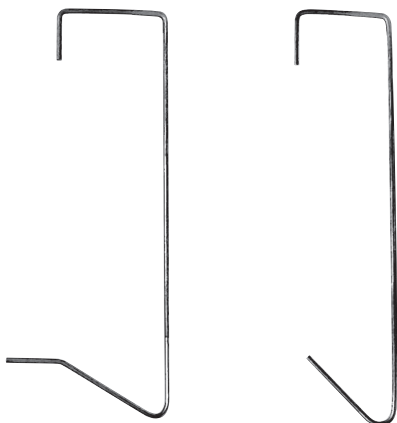

Part No. FPH51 – (1½" to 2½" Dia.)
Foreign car pipe hooks.

Part No. PH450 – (2¾" to 4" Dia.)
H.D. pipe hooks.

Part No. PH50 – (1½" to 2½" Dia.)
Pipe hooks.

Part No. PH550 – (5" to 6" Dia.)
H.D. pipe hooks.

ACCESSORIES

Part No. BB1 – Bin Box

Part No. BB2 – Bin Box

Part No. AP2025 – Gasket/Flange Board

Part No. GC1 – Gasket Cards

MUFFLER CEMENT



Part No. T27 – 16oz.

This high-performance muffler cement applies like putty but dries metal hard. Available in cases of 12 only.



FORMERLY



ACPN

RECOGNIZED AP EMISSIONS TECHNOLOGIES BRANDS:



ShowMeTheParts

www.showmetheparts.com/apExhaust

Goldsboro, NC



Distributed By:



apemissions.com

FOR TECHNICAL SUPPORT:
Toll Free: 1.800.277.2787
Email: tech.line@apemissions.com
8 am - 5 pm, Monday through Friday

300 Dixie Trail
Goldsboro, NC 27530
Tel. 919.580.2000



© 2022 AP Emissions Technologies, Inc.

All Rights Reserved

Printed in USA